



Liebert®

DSE™ Packaged Solution
Thermal Management System

System Design Catalog
60-kW (15-ton) Capacity

The information contained in this document is subject to change without notice and may not be suitable for all applications. While every precaution has been taken to ensure the accuracy and completeness of this document, Vertiv assumes no responsibility and disclaims all liability for damages resulting from use of this information or for any errors or omissions. Refer to other local practices or building codes as applicable for the correct methods, tools, and materials to be used in performing procedures not specifically described in this document.

The products covered by this instruction manual are manufactured and/or sold by Vertiv. This document is the property of Vertiv and contains confidential and proprietary information owned by Vertiv. Any copying, use or disclosure of it without the written permission of Vertiv is strictly prohibited.

Names of companies and products are trademarks or registered trademarks of the respective companies. Any questions regarding usage of trademark names should be directed to the original manufacturer.

Technical Support Site

If you encounter any installation or operational issues with your product, check the pertinent section of this manual to see if the issue can be resolved by following outlined procedures. Visit <https://www.Vertiv.com/en-us/support/> for additional assistance.

TABLE OF CONTENTS

1 Nomenclature and Components	1
1.1 Liebert DSE060 Packaged Solution Configuration-number Nomenclature	1
1.2 Component Location	4
1.3 Air-flow Configurations	4
2 System Data	5
2.1 Capacity and Performance Data	5
2.2 Physical Data	6
3 Electrical Power Requirements	7
3.1 Electrical Field Connections	7
3.2 iCOM Control	8
4 Planning Guidelines	9
4.1 Unit Weights	9
4.2 Planning Dimensions	9
Appendices	11
Appendix A: Technical Support and Contacts	11
Appendix B: Submittal Drawings	13
Appendix C: Guide Specifications	15

This page intentionally left blank

1 NOMENCLATURE AND COMPONENTS

This section describes the configuration number for Liebert® DP060 units and components.

1.1 Liebert DSE060 Packaged Solution Configuration-number Nomenclature

The following tables describe each digit of the 40-digit DP060 configuration number. The 14-digit model number consists of the first 10 digits and last 4 digits of the configuration number.

Table 1.1 DSE060 Configuration-number Digits 1 to 10 Example

Configuration -number Digits 1 to 10 = first 10 digits of 14-digit model number									
1	2	3	4	5	6	7	8	9	10
D	P	0	6	0	T	P	1	A	D

Table 1.2 DSE060 Configuration-number Detail Digits 11 to 21 Example

Configuration-number Detail Digits 11 to 21										
11	12	13	14	15	16	17	18	19	20	21
0	2	0	8	1	6	L	D	B	0	P

Table 1.3 DSE060 Configuration-number Detail Digits 22 to 36 Example

Configuration-number Detail Digits 22 to 36														
22	23	24	25	26	27	28	29	30	31	32	33	34	35	36
0	A	A	1	0	0	0	0	0	0	0	0	0	0	0

Table 1.4 DSE060 Configuration-number Digits 37 to 40 Example

Configuration -number Digits 37 to 40 = last 4 digits of 14-digit model number			
37	38	39	40
#	#	#	A

Table 1.5 DSE060 Packaged Solution Configuration-number Digit Definitions

Digit	Description
Digits 1 and 2 = Product Family DP = Liebert® Packaged DSE	
Digit 3 to 5 = Cooling Capacity, kW Nominal sensible capacity, kW	
Digit 6 = Air Discharge T = Perimeter, top inlet/front supply	
Digit 7 = System Type P = Air-cooled, EconoPhase ready	
Digit 8 = Air-flow (Fan Type) 1 = EC plug fans	
Digit 9 = Power Supply A = 460 V / 3 ph / 60 Hz B = 575 V / 3 ph / 60 Hz C = 208 V / 3 ph / 60 Hz D = 230 V / 3 ph / 60 Hz	
Digit 10 = Cooling System D = Digital scroll, R-410A	
Digit 11 = Humidifier 0 = None	
Digit 12 = Display 2 = Liebert®COM High Definition	
Digit 13 = Options 0 = None	
Digit 14 = Air Filter 8 = MERV 8, 4-in. 9 = MERV 11, 4-in.	
Digit 15 = Coil Option 1 = Non-coated coils, evaporator and condenser	
Digit 16 = Enclosure Option 6 = Standard color, pebble-gray	
Digit 17 = High-voltage option L = Locking disconnect 6 = Dual disconnect with reversing starter	
Digit 18 = Option packages D = Low-voltage terminal package + Remote humidifier contact	

Table 1.5 DSE060 Packaged Solution Configuration-number Digit Definitions (continued)

Digit	Description
Digit 19 = Monitoring B = Base Comms & Connectivity	
Digit 20 = Sensors 0 = None	
Digit 21 = Packaging P = Domestic	
Digit 22 = Controls 0 = None S = Quick-start and Capacitive buffer (contact the factory)	
Digit 23 = EconoPhase A = Standard capacity	
Digit 24 = Condenser Coil A = Standard ambient condenser	
Digit 25 = 120-V Options 1 = 120V Utility Power, Customer-supplied T = 120-V utility power from main-unit power supply	
Digit 26 = Option 0 = No power meter P = Power meter (Contact the factory)	
Digit 27 = Option 0 = None	
Digit 28 = Option 0 = None	
Digit 29 = Condensate Pump 0 = None	
Digit 30 to 36 0 = Placeholder	
Digit 37 to 39 = Factory Configuration Number	
Digit 40 = Configuration Code A = No SFA S = SFA	

1.2 Component Location

The unit component locations are described in the submittal documents included in the [Submittal Drawings](#).

The following table lists the relevant documents by number and title.

Table 1.6 Component-location Drawings

Document Number	Title
DPN004597	Component Location, Perimeter Unit

1.3 Air-flow Configurations

Table 1.7 Air-flow Configuration Drawings

Document Number	Title
DPN004598	Airflow Schematic, Perimeter Unit
DPN004599	Evaporator Ducting Dimensional Data

2 SYSTEM DATA

2.1 Capacity and Performance Data

Table 2.1 Capacity Data for Packaged 60-Hz Models

Model Size:		DPO60
DX Evaporator - Net Capacity Data at 95°F (35°C) Outdoor Ambient		
95°F DB, 67.7°F WB, 52°F DP, 23% RH (35°C DB, 19.8.°C WB)	Total, kW (kBTUH)	54.6 (186)
	Sensible, kW (kBTUH)	54.6 (186)
	100% Compressor Mode - Net Full-Load SCOP, kW/kW	3.0
	100% Pump Mode at 35°F (1.7°C) Outdoor Ambient - Net Full-Load SCOP, kW/kW	8.4
85°F DB, 64.4°F WB, 52°F DP, 32% RH (29.4°C DB, 18°C WB)	Total, kW (kBTUH)	48.9 (167)
	Sensible, kW (kBTUH)	48.9 (167)
	100% Compressor Mode - Net Full-Load SCOP, kW/kW	2.7
	100% Pump Mode at 35°F (1.7°C) Outdoor Ambient - Net Full-Load SCOP, kW/kW	6.9
75°F DB, 61°F WB, 52°F DP, 44% RH (23.9°C DB, 16.1°C WB)	Total, kW (kBTUH)	44.2 (151)
	Sensible, kW (kBTUH)	41.8 (143)
	100% Compressor Mode - Net Full-Load SCOP, kW/kW	2.4
	100% Pump Mode at 35°F (1.7°C) Outdoor Ambient - Net Full-Load SCOP, kW/kW	5.3
Fan Section - EC Fans		
Standard Air Volume - CFM (CMH)		7,200 (12,233)
External Static Pressure, in.w.g. (Pa)		0.2 (50 Pa)
<p>1. Some options or combinations of options may result in reduced air flow. Consult factory for recommendations.</p> <p>2. Application or unit is outside of the scope of AHRI Datacom Cooling Certification Program, but is rated in accordance with AHRI Standard 1360 (I-P) and ASHRAE Standard 127-2007. Consult factory for alternate performance outputs</p>		

2.2 Physical Data

Table 2.2 Physical Data for Packaged 60-Hz Models

Model Size:	DP060	
EVAPORATOR COIL - A-Frame (Downflow) - Copper Tube/Aluminum Fin		
Face Area, sq. ft. (sq. m.)	17.0 (1.6)	
Rows of Coil	6	
Face Velocity, FPM (m/s) at Std. Air Volume	423 (2.1)	
FAN SECTION		
Quantity of Fans	1	
Standard Fan Motor, HP (kW)	4.9 (3.7)	
Unit Piping Connection Sizes		
Condensate Drain, FPT	3/4"	
FILTER SECTION - Disposable Type - Nominal Sizes and Quantities, MERV8 and MERV11 (option)		
Nominal Size, inches	25 x 20	25 x 16
Quantity	2	1

3 ELECTRICAL POWER REQUIREMENTS

The tables on the following pages list the electrical data.

Table 3.1 Electrical Data—DP060, 60 Hz

Unit Voltage Rating	Total System with Standard Ambient Condenser	Without 120-V Transformer	With 120-V Transformer
208 V, 3 ph, 60 Hz	FLA	70.1	76.4
	WSA	84.4	90.6
	OPD	125	125
230 V, 3 ph, 60 Hz	FLA	66.9	79.4
	WSA	79.8	92.3
	OPD	125	125
460 V, 3 ph, 60 Hz	FLA	33.2	125
	WSA	39.6	45.8
	OPD	60	60
575 V, 3 ph, 60 Hz	FLA	27.5	33.8
	WSA	33.0	39.3
	OPD	50	60

3.1 Electrical Field Connections

Three-phase electrical service is required for all models. Electrical service must conform to national and local electrical codes.

The electrical connections are described in the submittal documents included in the [Submittal Drawings](#).

The following table lists the relevant documents by number and title.

Table 3.2 Electrical Field-connection Drawings

Document Number	Title
DPN004587	Electrical Connections Enclosure, Dual power input
DPN004591	Electrical Connections Enclosure, Single power input
DPN004732	Evaporator Electrical Panel component definitions and locations
Unit-to-Unit Networking	
DPN004351	Liebert® iCOM Unit-to-unit Network Connections

3.2 iCOM Control

The Liebert® DSE Packaged Solution includes a unit-mounted iCOM control and display that manages operation of all thermal-management-system components.

The details are described in the submittal documents included in the [Submittal Drawings](#).

The following table lists the relevant documents by number and title.

Table 3.3 iCOM Details

Document Number	Title
DPN004350	Liebert® iCOM Unit-mounted display
DPN000960	Liebert® iCOM Remote temperature and humidity sensor
DPN003144	Liebert® iCOM Service bracket

4 PLANNING GUIDELINES

4.1 Unit Weights

Table 4.1 DP060 unit weights

Model	Weight, lb (kg)
Perimeter	5,500 (2,495)

4.2 Planning Dimensions

The unit and anchor dimensions are described in the submittal documents included in the [Submittal Drawings](#).

The following table lists the relevant documents by number and title.

Table 4.2 Dimension Planning Drawings

Document Number	Title
DPN004600	Cabinet and Anchor Dimensional Data
DPN004599	Evaporator Ducting Dimensional Data
DPN004601	Condensate-drain Access and Location
DPN004602	Evaporator Compartment Service Area
DPN004756	Installation and Service Clearance for Multiple Units

This page intentionally left blank

APPENDICES

Appendix A: Technical Support and Contacts

A.1 Technical Support/Service in the United States

Vertiv™ Group Corporation

24x7 dispatch of technicians for all products.

1-800-543-2378

Liebert® Thermal Management Products

1-800-543-2778

Liebert® Channel Products

1-800-222-5877

Liebert® AC and DC Power Products

1-800-543-2378

A.2 Locations

United States

Vertiv Headquarters

1050 Dearborn Drive

Columbus, OH, 43085, USA

Europe

Via Leonardo Da Vinci 8 Zona Industriale Tognana

35028 Piove Di Sacco (PD) Italy

Asia

7/F, Dah Sing Financial Centre

3108 Gloucester Road

Wanchai, Hong Kong

This page intentionally left blank

Appendix B: Submittal Drawings

The submittal drawings are in the order of document part number (DPN). **Table B.1** below, groups the drawings by topic/application.

Table B.1 Submittal Drawing Contents

Document Number	Title
Component Locations	
DPN004597	Component Location, Perimeter Unit
Perimeter unit air-flow schematic and duct connection	
DPN004598	Airflow Schematic, Perimeter Unit
DPN004599	Evaporator Ducting Dimensional Data
Electrical Field-connection Drawings	
DPN004587	Electrical Connections Enclosure, Dual power input
DPN004591	Electrical Connections Enclosure, Single power input
DPN004732	Evaporator Electrical Panel component definitions and locations
Unit-to-Unit Networking	
DPN004351	Liebert® iCOM Unit-to-unit Network Connections
iCOM Details	
DPN004350	Liebert® iCOM Unit-mounted display
DPN000960	Liebert® iCOM Remote temperature and humidity sensor
DPN003144	Liebert® iCOM Service bracket
Dimension Planning Drawings	
DPN004600	Cabinet and Anchor Dimensional Data
DPN004599	Evaporator Ducting Dimensional Data
DPN004601	Condensate-drain Access and Location
DPN004602	Evaporator Compartment Service Area
DPN004756	Installation and Service Clearance for Multiple Units

COMPONENT LOCATION DIAGRAM EVAPORATOR COMPARTMENT DP060 TOP INLET/FRONT SUPPLY

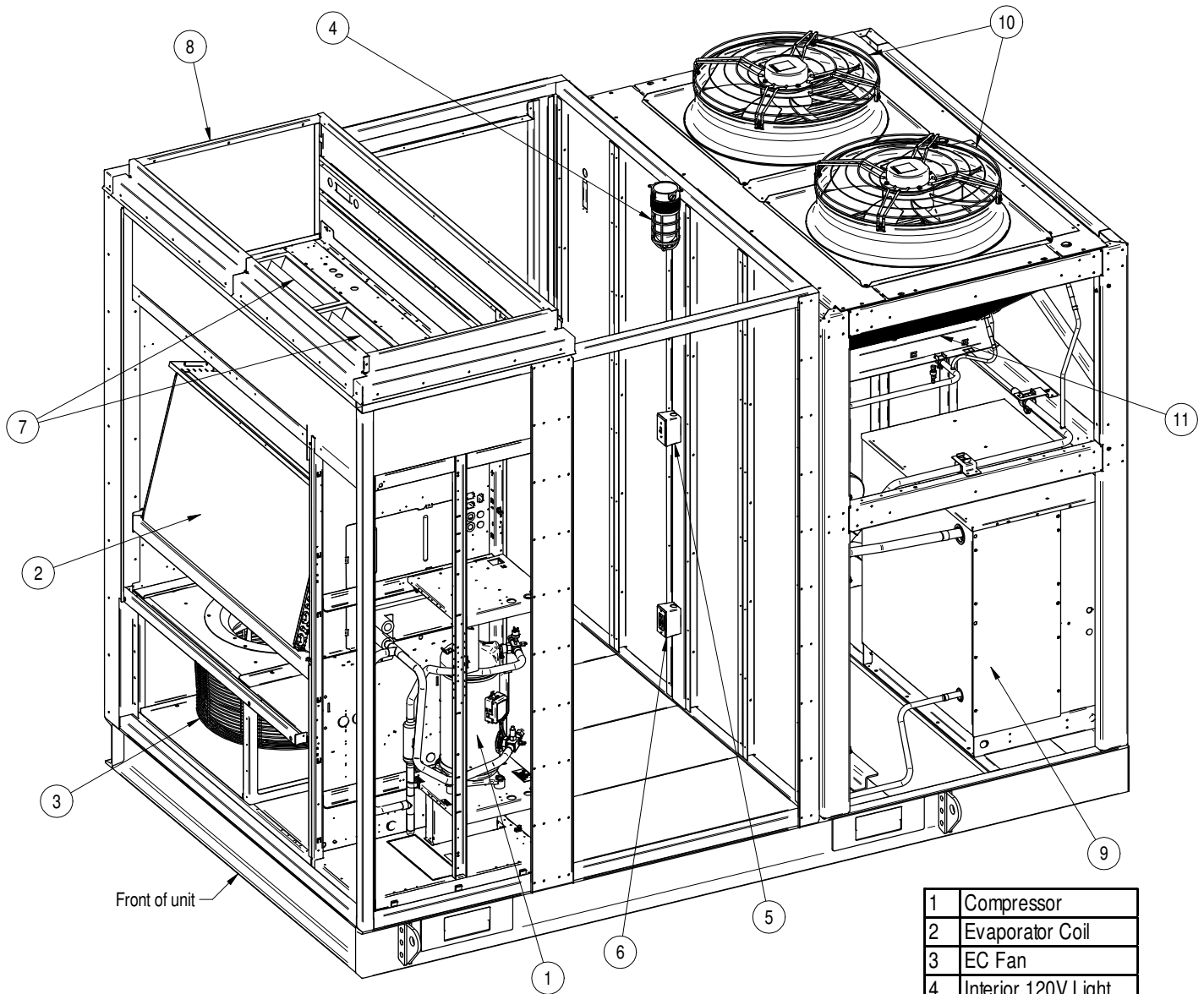

1	Compressor
2	Evaporator Coil
3	EC Fan
4	Interior 120V Light
5	Light Switch
6	GFI Outlet
7	Filters (qty. 3)
8	Duct Collar
9	Liebert EconoPhase
10	Condenser Fans
11	Condenser Coil

AIRFLOW SCHEMATIC DP060 TOP INLET/FRONT SUPPLY

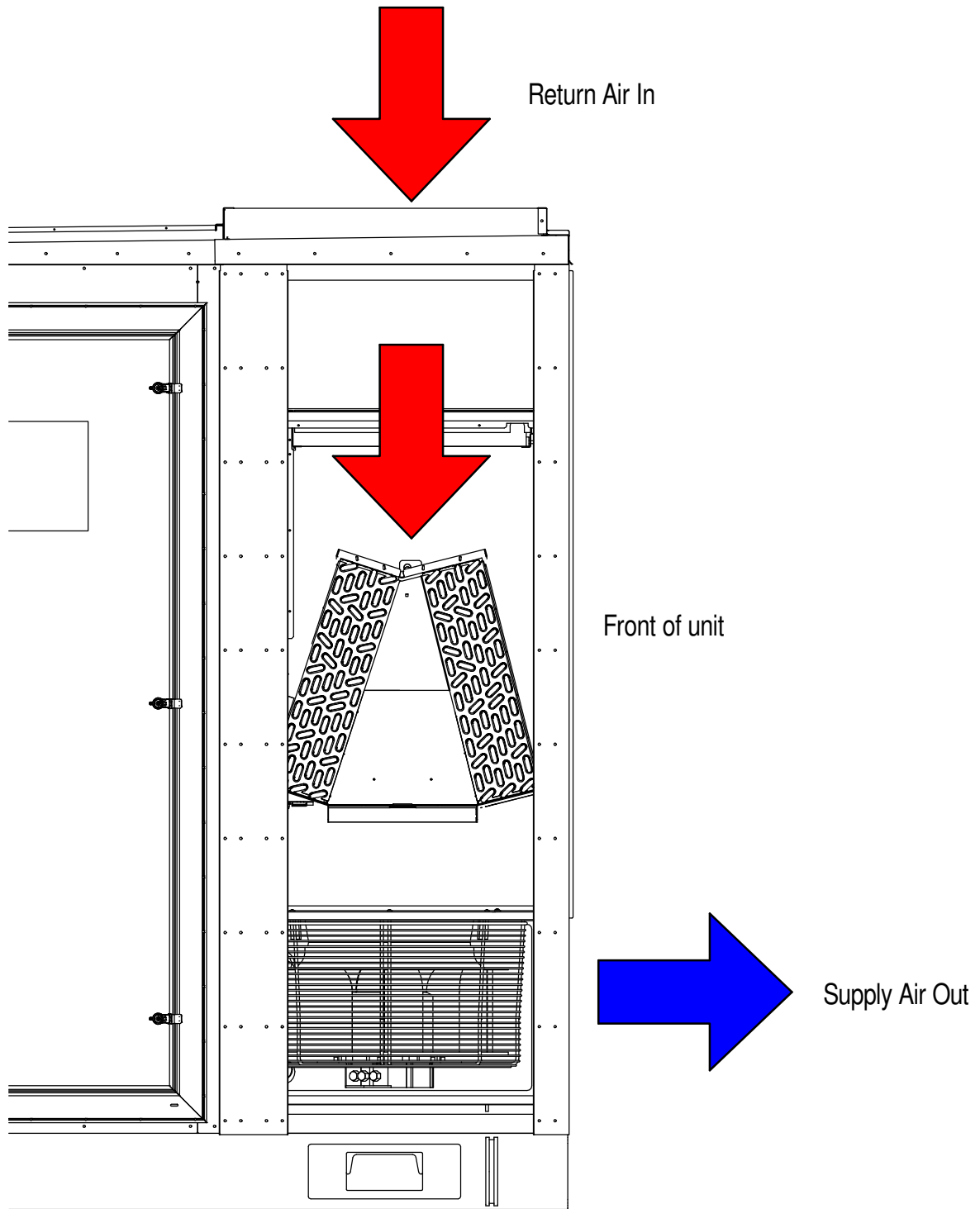

Some panels removed for clarity

EVAPORATOR DUCTING DIMENSIONAL DATA DP060 TOP INLET/FRONT SUPPLY

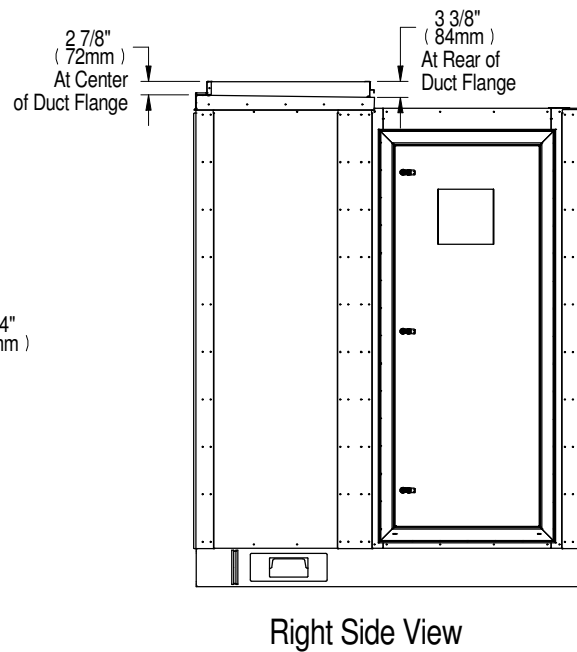
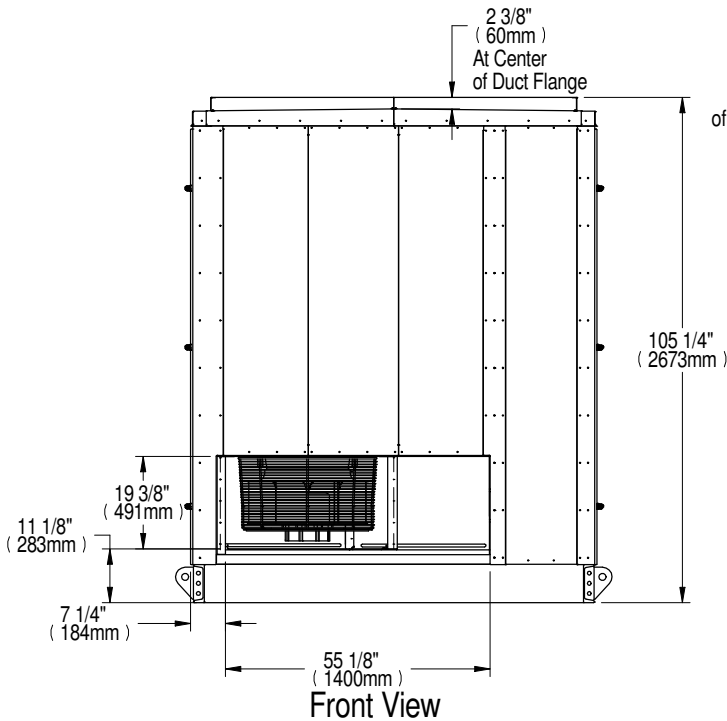
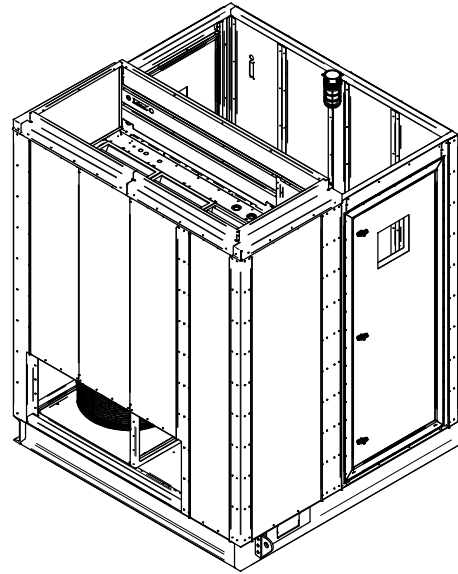
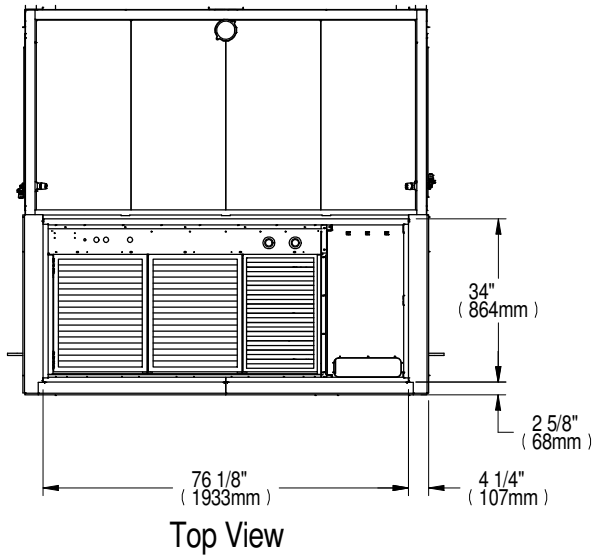

Notes:

1. Seal all ducts.

ELECTRICAL FIELD CONNECTIONS DP060 UNIT DEFINITIONS AND LOCATIONS DUAL POWER INPUT

STANDARD ELECTRICAL CONNECTIONS

- 1) **HIGH VOLTAGE ENTRANCE** – This area will be used for the high voltage fittings. Enclosure is not provided with holes or knockouts, which must be done by the installer in the field. The fittings, supplied by others, must have the proper environmental rating per code.
- 2) **LOW VOLTAGE ENTRANCE** – This area will be used for the low voltage and communication fittings. Enclosure is not provided with holes or knockouts, which must be done by the installer in the field. The fittings, supplied by others, must have the proper environmental rating per code.
- 3) **HIGH VOLTAGE WIRE DUCT** – Wire duct to be used by the installer for high voltage wire routing.
- 4) **SOURCE 1 MAIN UNIT POWER CONNECTIONS** – Terminals are located on top of the locking disconnect switch. See side of disconnect switch for wire range and tightening torque. Three phase service not provided by Liebert. Wire range and tightening torque will vary based on disconnect size. Refer to label on side of disconnect.
- 5) **EARTH GROUND CONNECTION FOR SOURCE 1 MAIN UNIT POWER** – Terminal for field supplied Source 1 earth grounding wire. Earth grounding required for Liebert units. 14-2AWG wire range, 275 in-lb wire tightening torque.
- 6) **SOURCE 2 MAIN UNIT POWER CONNECTIONS** - Terminals are located on top of the locking disconnect switch. See side of disconnect switch for wire range and tightening torque. Three phase service not provided by Liebert. Wire range and tightening torque will vary based on disconnect size. Refer to label on side of disconnect.
- 7) **EARTH GROUND CONNECTION FOR SOURCE 2 MAIN UNIT POWER** - Terminal for field supplied Source 2 earth grounding wire. Earth grounding required for Liebert units. 14-2AWG wire range, 275 in-lb wire tightening torque.
- 8) **REMOTE SHUTDOWN** - Replace existing jumper between terminals 37 & 38 with field supplied normally closed switch having a minimum 75VA, 24VAC rating. Use field supplied Class 1 wiring.
- 9) **CUSTOMER ALARM INPUTS** – Terminals for field supplied, normally open contacts, having a minimum 75va, 24vac rating, between terminals 24 & 50, 51, 56. Use field supplied Class 1 wiring. Terminal availability varies by unit options.
- 10) **COMMON ALARM** – On any alarm, normally open dry contact is closed across terminals 75 & 76 for remote indication. 1 AMP, 24VAC max load. Use Class 1 field supplied wiring.
- 11) **REMOTE HUMIDIFIER** – On any call for humidification, normally open dry contact is closed across terminals 11 & 12 to signal field supplied remote humidifier. 1 AMP, 24VAC max load. Use Class 1 field supplied wiring.
- 12) **FIELD SUPPLIED 120V UTILITY POWER** – Terminals for the connection of a field supplied 120V 20A utility power to feed the light and service electrical outlet. 22-8AWG wire range, 14.2lb-in tightening torque.
- 13) **EARTH GROUNDING CONNECTION FOR FIELD SUPPLIED 120V UTILITY POWER** - Terminal for field supplied 120V earth grounding wire. Earth grounding required for Liebert units. 14-2/0AWG wire range, 14-8AWG – 75lb-in, 6-4AWG – 110lb-in, 2-1AWG – 150lb-in, 1/0 – 2/0AWG – 180lb-in.

LOW VOLTAGE TERMINAL PACKAGE CONNECTIONS

- 14) **EXTRA REMOTE UNIT SHUTDOWN** – Two additional contact pairs available for unit shutdown (labeled as 37B & 38B, 37C & 38C). Replace jumpers with field supplied normally closed switch having a minimum 75VA, 24VAC rating. Use field supplied Class 1 wiring.
- 15) **EXTRA COMMON ALARM** – On any alarm, two additional normally open contacts are closed across terminals 94 & 95 and 96 & 97 for remote indication. 1 AMP, 24VAC max load. Use Class 1 field supplied wiring.
- 16) **MAIN FAN AUXILIARY SWITCH** – On closure of the main fan contactor, normally open dry contact is closed across terminals 84 & 85 for remote indication. 1 AMP, 24VAC max load. Use Class 1 field supplied wiring.
- 17) **LIQUITECT SHUTDOWN AND DRY CONTACT** – On LiquiTect activation, normally open dry contact is closed across terminals 58 & 59 for remote indication (LiquiTect sensor ordered separately). 1 AMP, 24VAC max load. Use Class 1 field supplied wiring.

NOTE: All low voltage terminal connections are spring-cage with a wire range of 28-12AWG.

NOTE: Items 12 and 13 may not be present if Unit supplied 120V utility option is selected.

ELECTRICAL FIELD CONNECTIONS DP060 UNIT DEFINITIONS AND LOCATIONS DUAL POWER INPUT

STANDARD COMMUNICATION CONNECTIONS

- 18) **RS485 BMS CONNECTION** – Terminal TB3-1 is TX/RX+. Terminal TB3-2 is TX/RX-. Terminal TB3-3 is earth ground. Use shielded cable with 120ohm characteristic impedance. (Supplied by other).
- 19) **CANBUS REMOTE SENSOR CONNECTION(P67)** – Remove the inserted plug from this connector and attach the remote sensor cable to power and communicate with Liebert remote Temperature/humidity sensors. Use shielded cable with 120ohm characteristic impedance. (Supplied by other).
- 20) **ETHERNET BMS CONNECTION(P74)** – RJ-45 connection for connecting to BMS Ethernet network. Use Class 5 shielded cable (Supplied by other).
- 21) **ETHERNET UNIT TO UNIT CONNECTION(P64)** – RJ-45 connection for connecting to other units. Use Class 5 shielded cable (Supplied by other).

NOTE: All low voltage terminal connections are spring-cage with a wire range of 28-12AWG.

NOTE: All communication cables should be kept separate from high-voltage wiring.

OPTIONAL ELECTRICAL CONNECTIONS

(Check factory for availability)

- 22) **SMOKE SENSOR ALARM** – Factory wired dry contacts from smoke sensor are 91-common, 92-Normally Open, and 93-Normally Closed. Supervised contacts, 80 & 81, open on sensor trouble indication. This smoke sensor is not intended to function as, or replace, any room smoke detection system that may be required by local or national codes. 1 AMP, 24VAC max load. Use Class 1 field supplied wiring.
- 23) **SPARE TERMINALS** – Spare terminals for Class 1 field supplied wiring.

NOTE: Terminals for item 22 and 23 are always present. Refer to the order to verify if the options are installed on the unit.
Refer to specification sheet for total unit full load amps, wire size amps, and max overcurrent protection device size.

ELECTRICAL FIELD CONNECTIONS DP060 UNIT DEFINITIONS AND LOCATIONS DUAL POWER INPUT

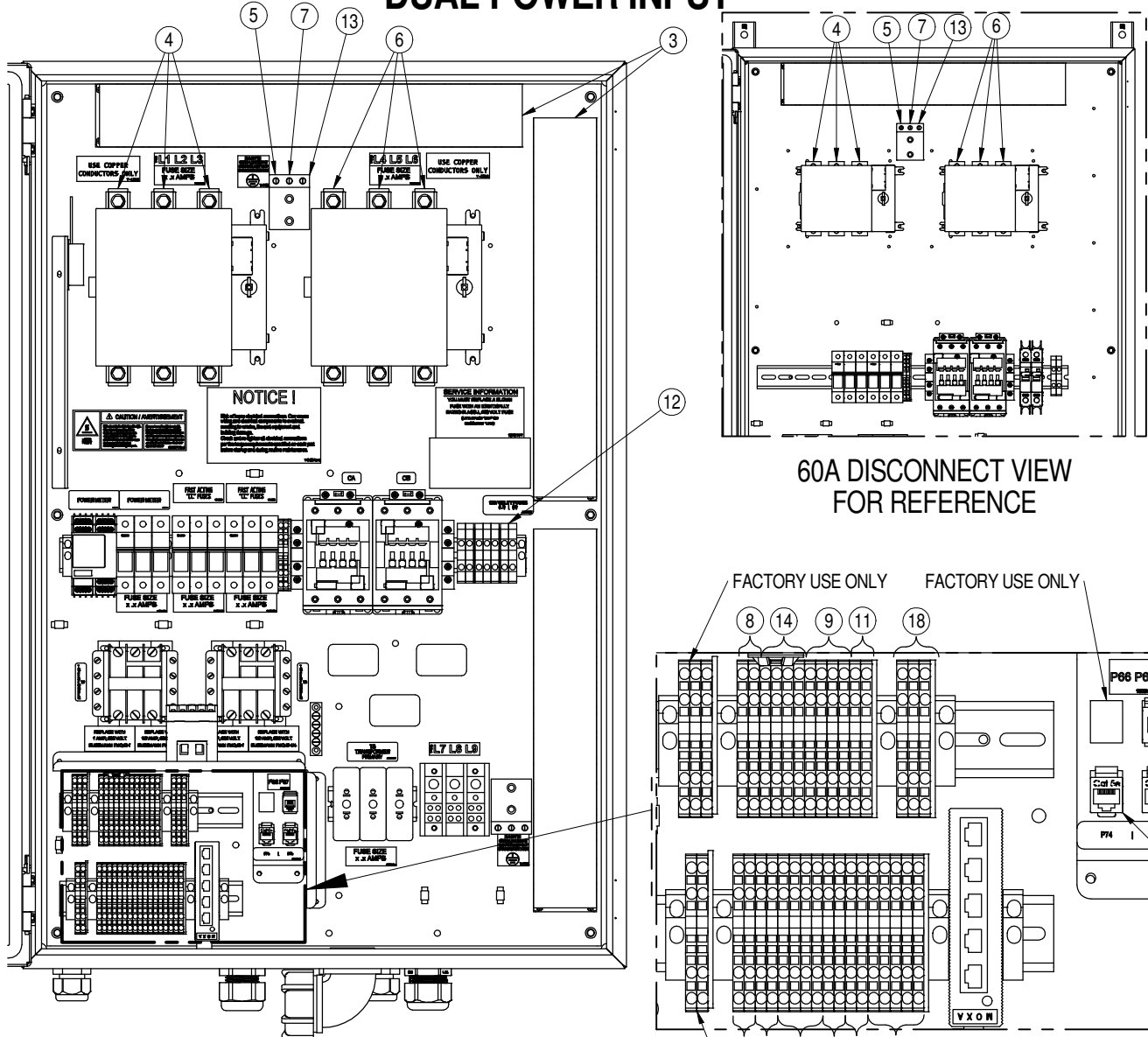

60A DISCONNECT VIEW
FOR REFERENCE

200A DISCONNECT VIEW

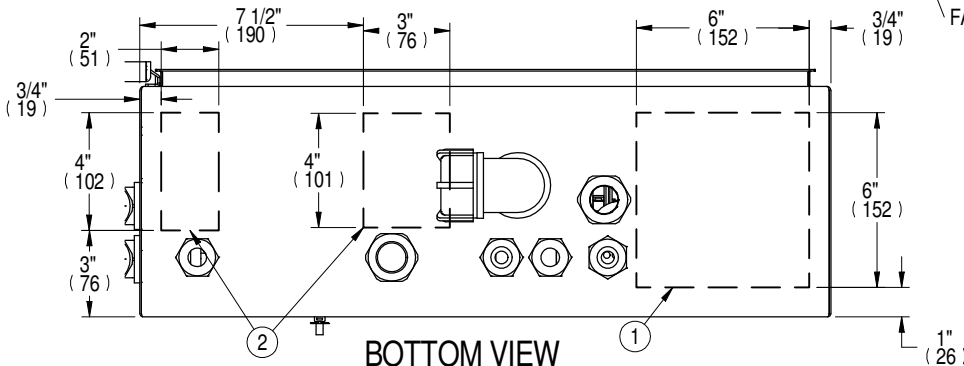

BOTTOM VIEW

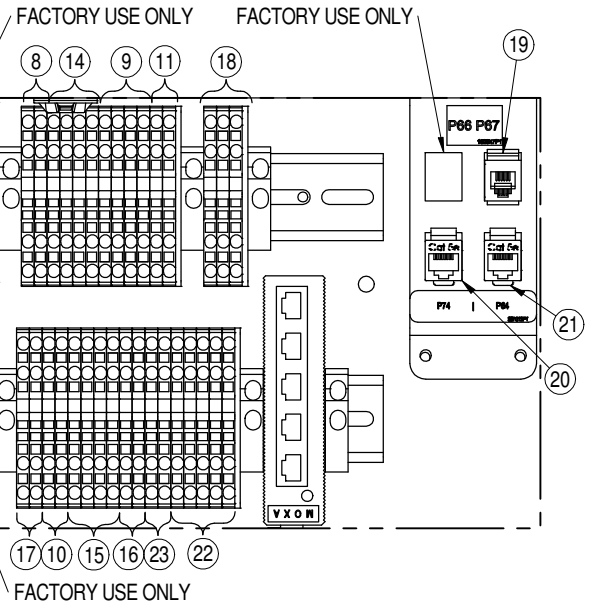

FACTORY USE ONLY

FACTORY USE ONLY

ELECTRICAL FIELD CONNECTIONS DP060 UNIT DEFINITIONS AND LOCATIONS DUAL POWER INPUT

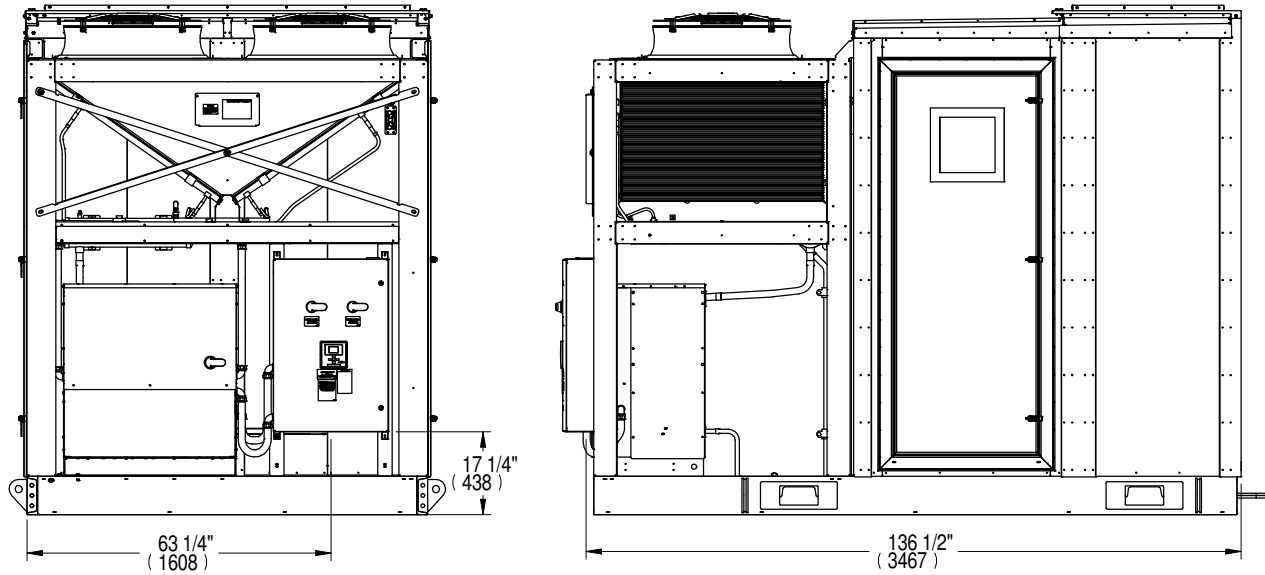

APPROXIMATE LOCATION OF EP ON UNIT

DP060 ENCLOSURE ELECTRICAL LOCATIONS

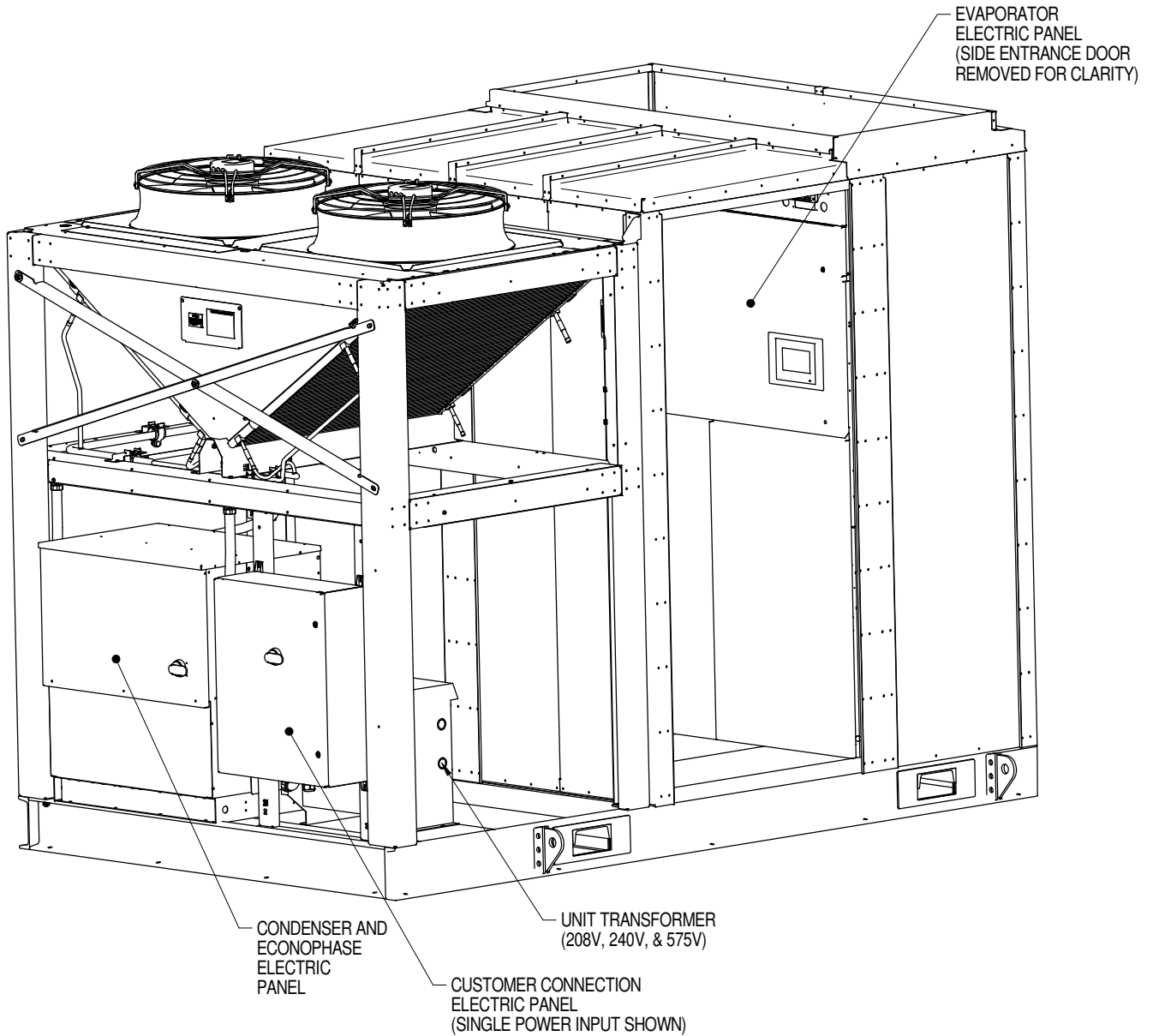

DP060 CUSTOMER CONNECTION ELECTRICAL PANEL COMPONENT DEFINITIONS AND LOCATIONS DUAL POWER INPUT

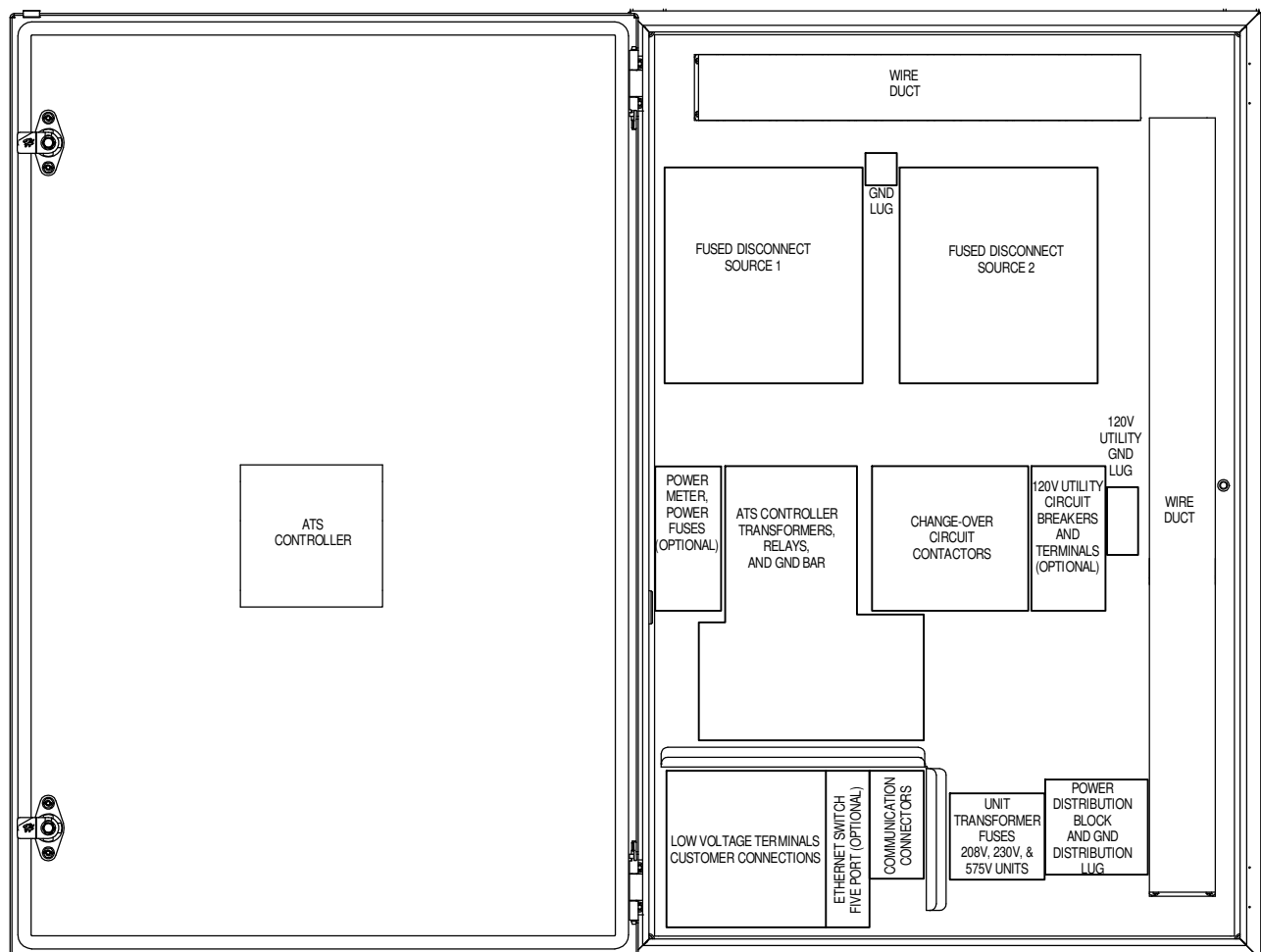
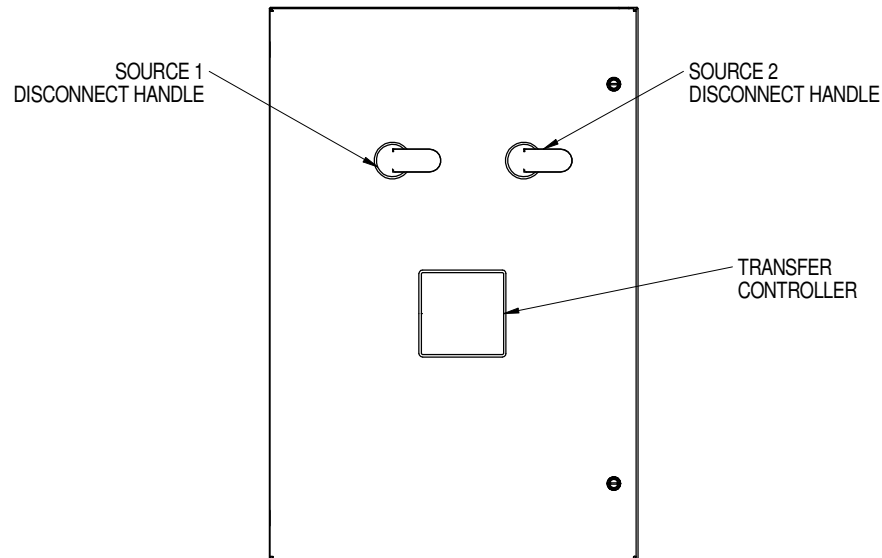

DP060 CUSTOMER CONNECTION ELECTRICAL PANEL COMPONENT DEFINITIONS AND LOCATIONS SINGLE POWER INPUT

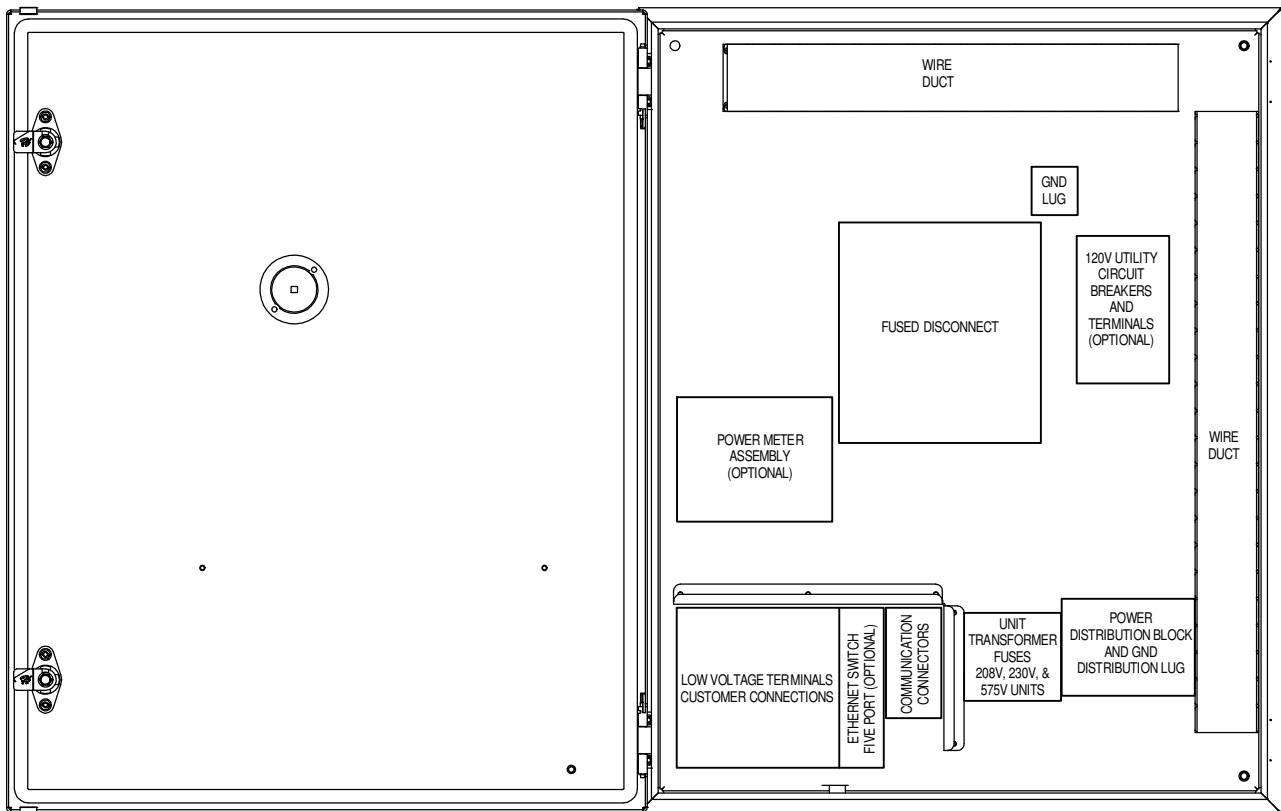
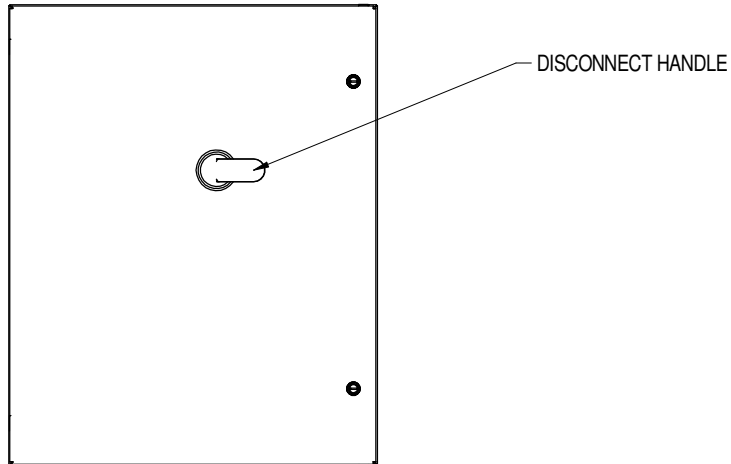



LIEBERT DSE

DP060 CONDENSER AND ECONOPHASE ELECTRICAL PANEL COMPONENT DEFINITIONS AND LOCATIONS

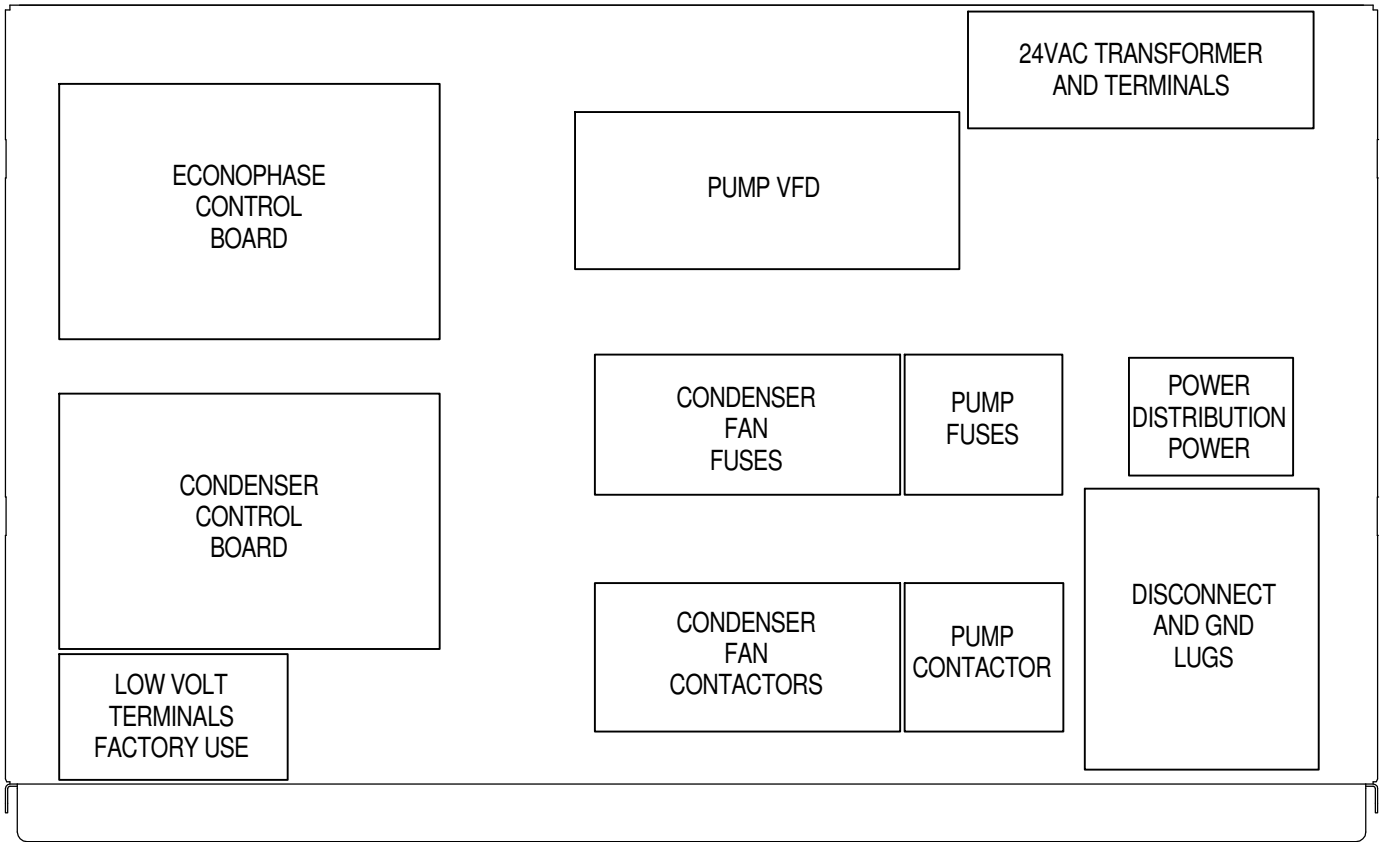



LIEBERT DSE

DP060 EVAPORATOR ELECTRICAL PANEL COMPONENT DEFINITIONS AND LOCATIONS

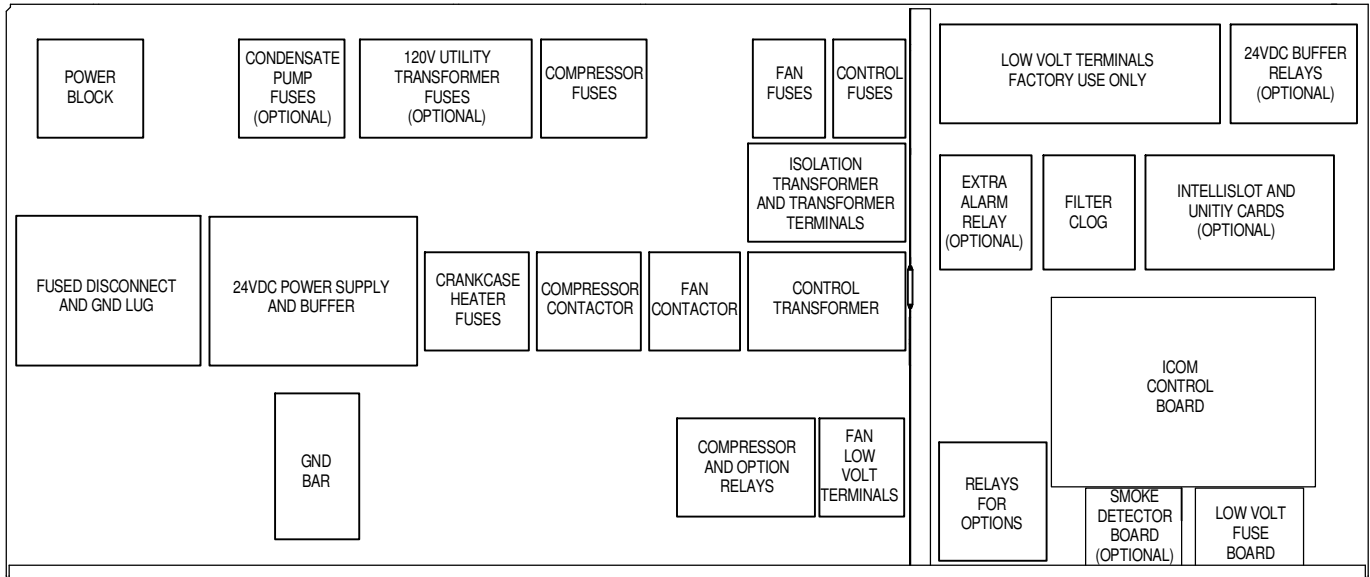

ELECTRICAL FIELD CONNECTIONS DP060 UNIT DEFINITIONS AND LOCATIONS SINGLE POWER INPUT

STANDARD ELECTRICAL CONNECTIONS

- 1) **HIGH VOLTAGE ENTRANCE** – This area will be used for the high voltage fittings. Enclosure is not provided with holes or knockouts, which must be done by the installer in the field. The fittings, supplied by others, must have the proper environmental rating per code.
- 2) **LOW VOLTAGE ENTRANCE** – This area will be used for the low voltage and communication fittings. Enclosure is not provided with holes or knockouts, which must be done by the installer in the field. The fittings, supplied by others, must have the proper environmental rating per code.
- 3) **HIGH VOLTAGE WIRE DUCT** – Wire duct to be used by the installer for high voltage wire routing.
- 4) **MAIN UNIT POWER CONNECTIONS** – Terminals are located on top of the locking disconnect switch. See side of disconnect switch for wire range and tightening torque. Three phase service not provided by Liebert. Wire range and tightening torque will vary based on disconnect size. Refer to label on side of disconnect.
- 5) **EARTH GROUND CONNECTION FOR MAIN UNIT POWER** – Terminal for field supplied Source 1 earth grounding wire. Earth grounding required for Liebert units. 14-2AWG wire range, 275 in-lb wire tightening torque.
- 6) **REMOTE SHUTDOWN** - Replace existing jumper between terminals 37 & 38 with field supplied normally closed switch having a minimum 75VA, 24VAC rating. Use field supplied Class 1 wiring.
- 7) **CUSTOMER ALARM INPUTS** – Terminals for field supplied, normally open contacts, having a minimum 75va, 24vac rating, between terminals 24 & 50, 51, 56. Use field supplied Class 1 wiring. Terminal availability varies by unit options.
- 8) **COMMON ALARM** – On any alarm, normally open dry contact is closed across terminals 75 & 76 for remote indication. 1 AMP, 24VAC max load. Use Class 1 field supplied wiring.
- 9) **REMOTE HUMIDIFIER** – On any call for humidification, normally open dry contact is closed across terminals 11 & 12 to signal field supplied remote humidifier. 1 AMP, 24VAC max load. Use Class 1 field supplied wiring.
- 10) **FIELD SUPPLIED 120V UTILITY POWER** – Terminals for the connection of a field supplied 120V 20A utility power to feed the light and service electrical outlet. 22-8AWG wire range, 14.2lb-in tightening torque.
- 11) **EARTH GROUNDING CONNECTION FOR FIELD SUPPLIED 120V UTILITY POWER** - Terminal for field supplied 120V earth grounding wire. Earth grounding required for Liebert units. 14-2AWG wire range, 275 in-lb wire tightening torque.

LOW VOLTAGE TERMINAL CONNECTIONS

- 12) **EXTRA REMOTE UNIT SHUTDOWN** – Two additional contact pairs available for unit shutdown (labeled as 37B & 38B, 37C & 38C). Replace jumpers with field supplied normally closed switch having a minimum 75VA, 24VAC rating. Use field supplied Class 1 wiring.
- 13) **EXTRA COMMON ALARM** – On any alarm, two additional normally open contacts are closed across terminals 94 & 95 and 96 & 97 for remote indication. 1 AMP, 24VAC max load. Use Class 1 field supplied wiring.
- 14) **MAIN FAN AUXILIARY SWITCH** – On closure of the main fan contactor, normally open dry contact is closed across terminals 84 & 85 for remote indication. 1 AMP, 24VAC max load. Use Class 1 field supplied wiring.
- 15) **LIQUITECT SHUTDOWN AND DRY CONTACT** – On LiquiTect activation, normally open dry contact is closed across terminals 58 & 59 for remote indication (LiquiTect sensor ordered separately). 1 AMP, 24VAC max load. Use Class 1 field supplied wiring.

NOTE: All low voltage terminal connections are spring-cage with a wire range of 28-12AWG.

NOTE: Items 10 and 11 are not present when the Unit supplied 120V utility option is selected.



LIEBERT DSE

ELECTRICAL FIELD CONNECTIONS DP060 UNIT DEFINITIONS AND LOCATIONS SINGLE POWER INPUT

STANDARD COMMUNICATION CONNECTIONS

- 16) **RS485 BMS CONNECTION** – Terminal TB3-1 is TX/RX+. Terminal TB3-2 is TX/RX-. Terminal TB3-3 is earth ground. Use shielded cable with 120ohm characteristic impedance. (Supplied by other).
- 17) **CANBUS REMOTE SENSOR CONNECTION(P67)** – Remove the inserted plug from this connector and attach the remote sensor cable to power and communicate with Liebert remote Temperature/humidity sensors. Use shielded cable with 120ohm characteristic impedance. (Supplied by other).
- 18) **ETHERNET BMS CONNECTION(P74)** – RJ-45 connection for connecting to BMS Ethernet network. Use Class 5 shielded cable (Supplied by other).
- 19) **ETHERNET UNIT TO UNIT CONNECTION(P64)** – RJ-45 connection for connecting to other units. Use Class 5 shielded cable (Supplied by other).

NOTE: All low voltage terminal connections are spring-cage with a wire range of 28-12AWG.

NOTE: All communication cables should be separated from high-voltage wiring.

OPTIONAL ELECTRICAL CONNECTIONS

(Contact factory for availability)

- 20) **SMOKE SENSOR ALARM** – Factory wired dry contacts from smoke sensor are 91-common, 92-Normally Open, and 93-Normally Closed. Supervised contacts, 80 & 81, open on sensor trouble indication. This smoke sensor is not intended to function as, or replace, any room smoke detection system that may be required by local or national codes. 1 AMP, 24VAC max load. Use Class 1 field supplied wiring.
- 21) **SPARE TERMINALS** – Spare terminals for Class 1 field supplied wiring.

NOTE: All low voltage terminal connections are spring-cage with a wire range of 28-12AWG.

NOTE: Terminals for item 20 and 21 are always present. Refer to the order to verify if the options are present.

Refer to specification sheet for total unit full load amps, wire size amps, and max overcurrent protection device size.

ELECTRICAL FIELD CONNECTIONS DP060 UNIT DEFINITIONS AND LOCATIONS SINGLE POWER INPUT

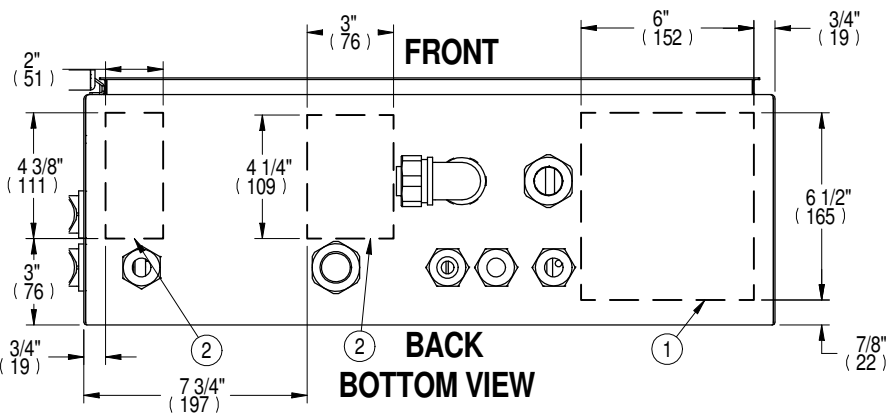
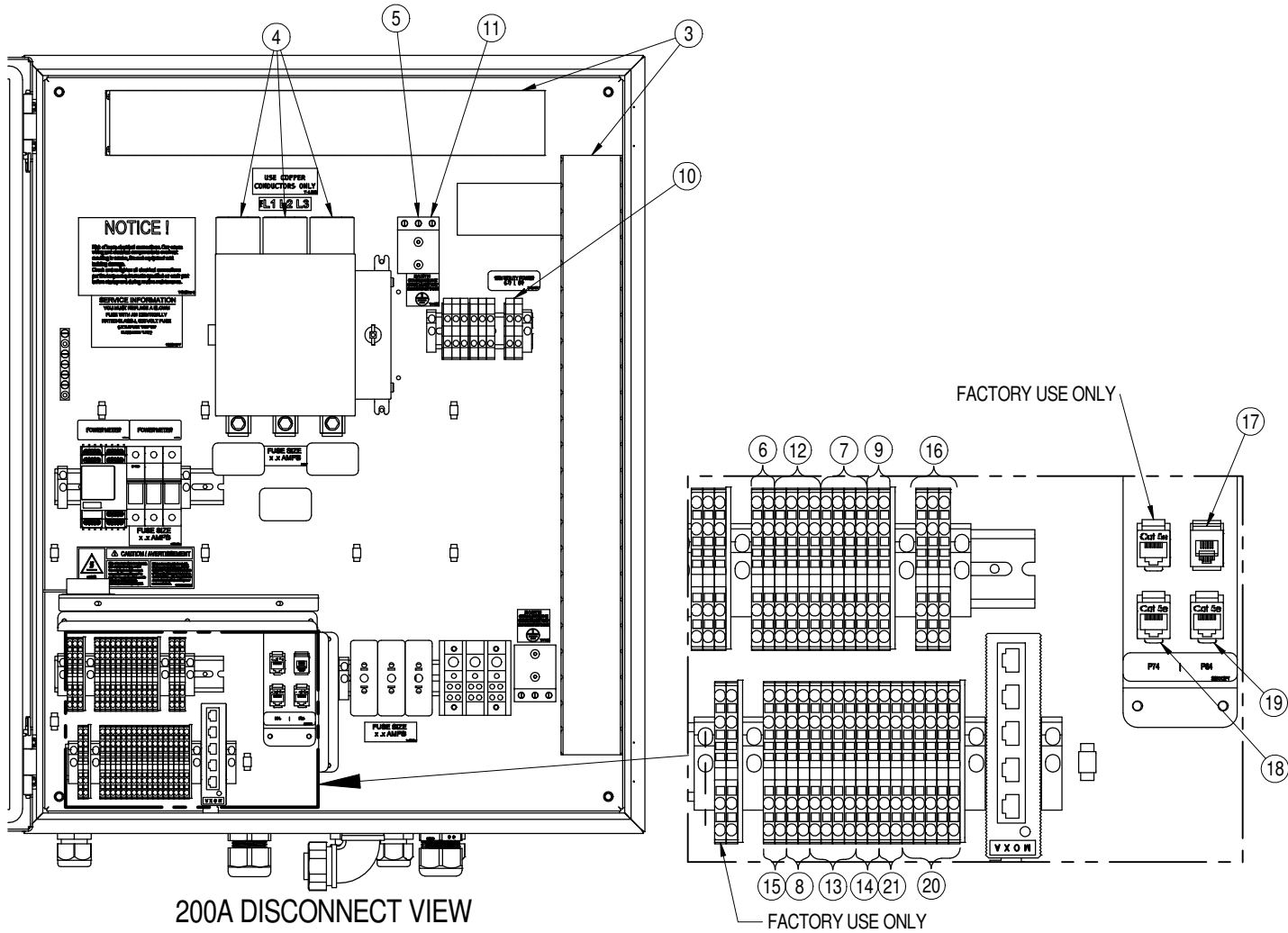

ELECTRICAL FIELD CONNECTIONS DP060 UNIT DEFINITIONS AND LOCATIONS SINGLE POWER INPUT

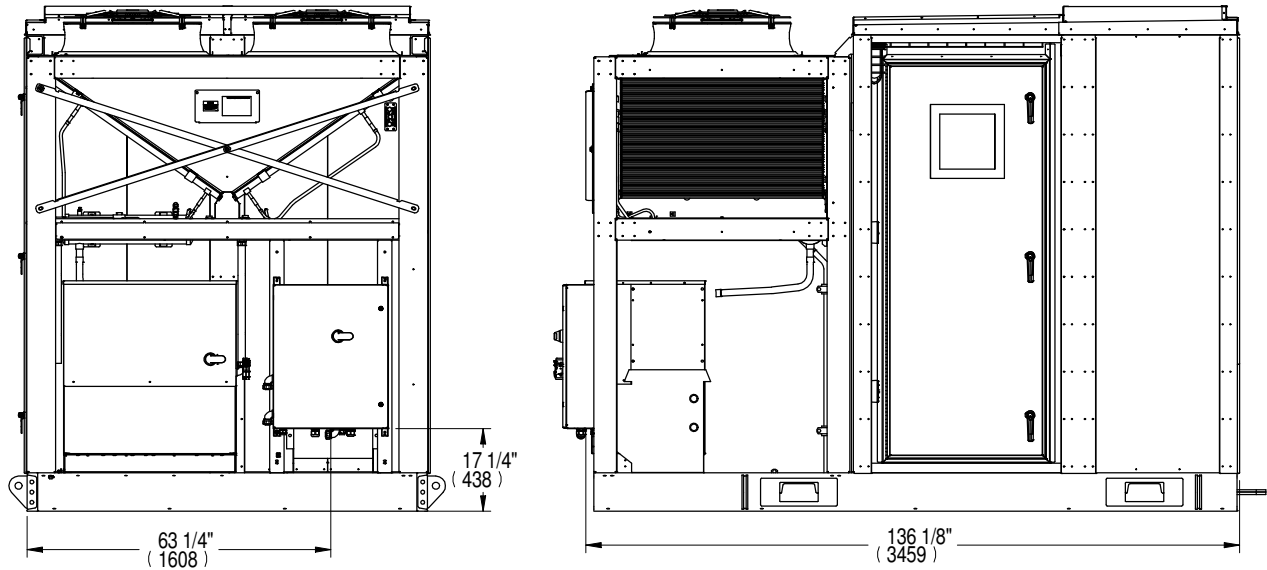

APPROXIMATE LOCATION OF EP ON UNIT



LIEBERT DS, DSE, CW, PDX & PCW

UNIT TO UNIT NETWORK CONNECTIONS

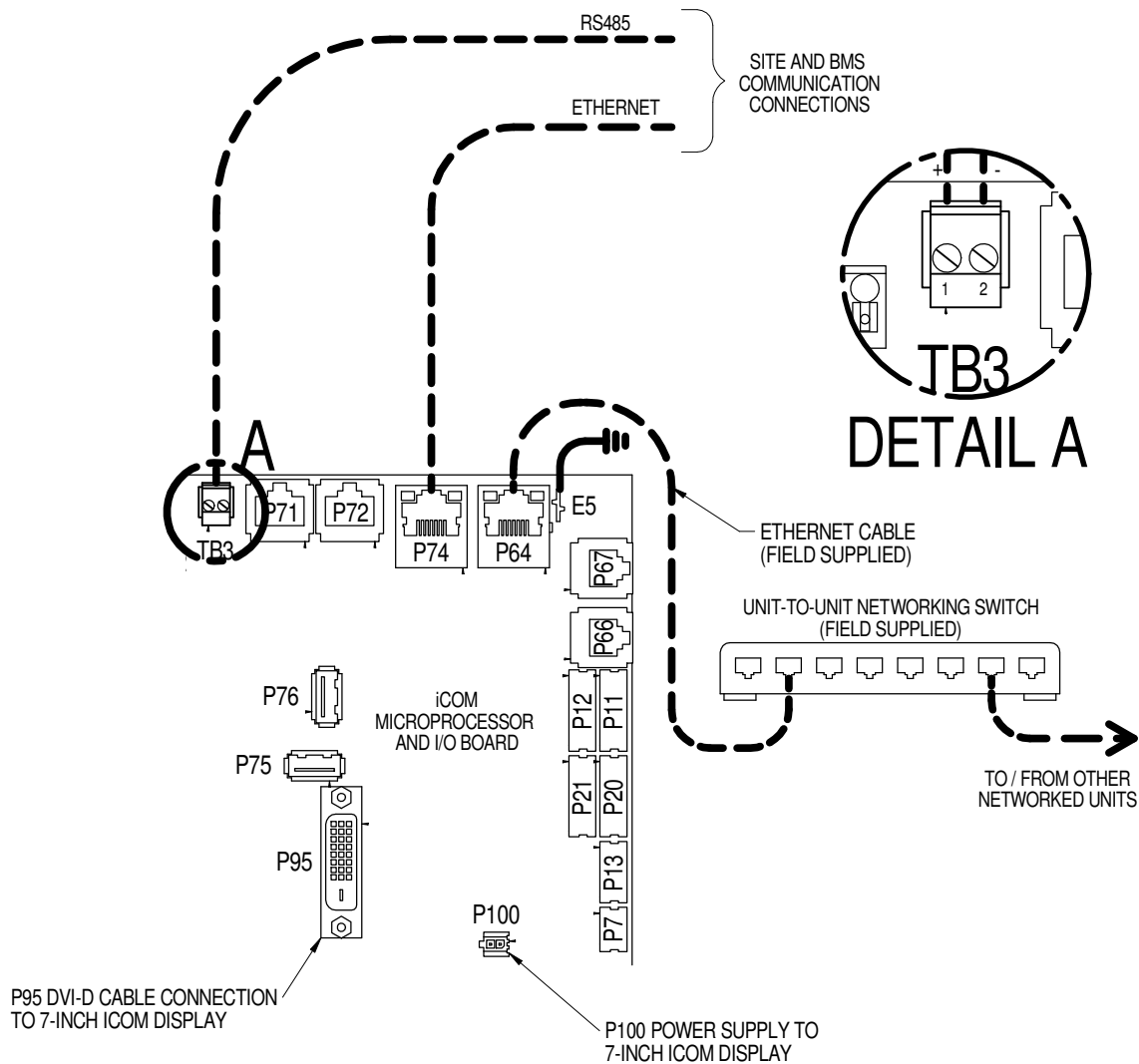

UNIT TO UNIT NETWORK CONNECTIONS

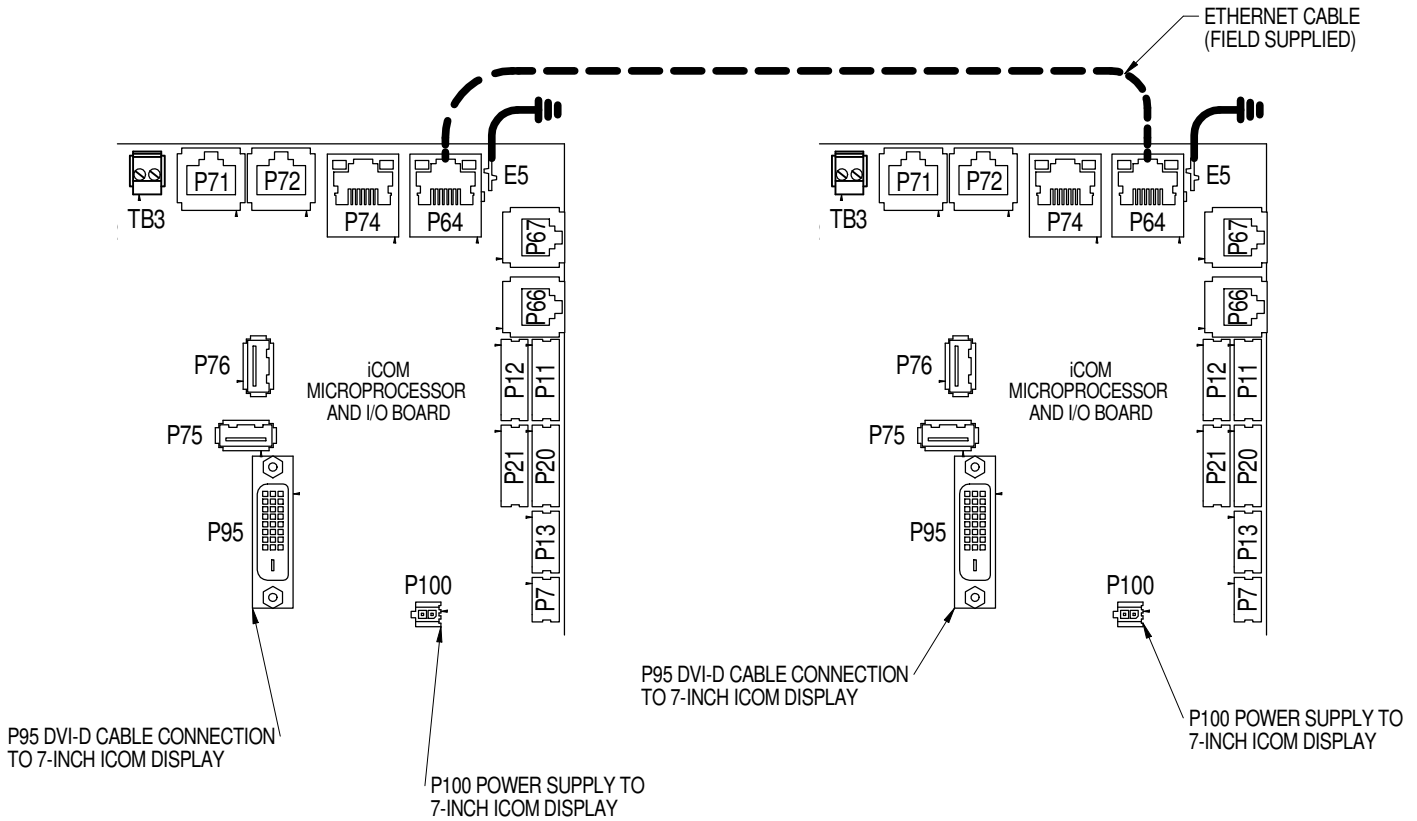

NOTE* For dual-unit network configurations only

PRODUCT INFORMATION UNIT MOUNTED DISPLAY



The Liebert iCOM™ display is a 7-inch capacitive, color-touchscreen display in an ergonomic, aesthetically pleasing housing. The display and housing will be viewable while the unit accent panels are open or closed. The display can be easily detached to view while the panel is open.

Menu Layout- The menus will be broken out into two main menu screens: User screen and Service screen. The User screen contains the menus to access parameters required for basic unit control and setup. The Service screen is designed for service personal and provides access to advanced control setup features and diagnostic information.

Password Protection- The display will contain two unique passwords to protect against unauthorized changes. An auto hide/show feature allows the user to see applicable information based on the login used. These four-digit passwords may be customized according to User preference.

Parameter Search- The display has search fields for efficient navigation and parameter lookup.



LIEBERT iCOM™

PRODUCT INFORMATION

UNIT MOUNTED DISPLAY

Context Sensitive Help- The display will have an onboard help database. The database will provide context sensitive help to assist with setup and navigation of the menus.

Display Setup- The user has the ability to configure the display information based on the specific user's preference. Language, units of measure, screen contrast, home screen layout, back light timer and the hide/show of certain readouts will be configurable through the display.

Additional Readouts- The display has the ability for the user to configure custom widgets on the main screen. Widget options will include items such as fan speed, call for cooling, call for free cooling, maintenance status, call for hot water reheat, call for electric reheat, call for dehumidification, call for humidification, airflow, static pressure, fluid flow rate and cooling capacity.

Status LEDs- The display will provide the user with the unit's operating status using an integrated LED. The LED will indicate if the unit has an active alarm; if the unit has an active alarm that has been acknowledged; or if the unit is on, off, or in a standby status.

Unit Alarms – All unit alarms are annunciated through both audio and visual cues, clearly displayed on the screen, automatically recorded in the event log, and communicated to monitoring plug connections.

Event Log – The display will automatically store the last 400 unit-only events (messages, warnings, and alarms).

Service Contact Information – The display has the ability to store the local service or sales contact information.

Upgradeable – Display and Control Board software upgrades are performed through a USB connection.

Unit-to-Unit (U2U) Communication – Communication via private Ethernet network allows for advanced control functionality (Teamwork modes, sharing sensor data, Standby Rotation, Lead-Lag, and Cascade operation).



LIEBERT iCOM™

PRODUCT INFORMATION UNIT MOUNTED DISPLAY

Parameter Directory- The Liebert iCOM shall provide a directory that lists all parameters in the control. The list shall provide Line ID numbers, parameter labels, and current parameter values.

Timers/Sleep Mode- The menus shall allow various customer settings for turning the unit On or Off.

Sensor Calibration- The menus shall allow unit sensors to be calibrated with external sensors.

Maintenance/Wellness Settings- The menus shall allow reporting of potential component problems before they occur.

Options Setup- The menus shall provide operation settings for the installed components.

Auxiliary Boards- The menus shall allow setup of optional expansion boards.

Various Sensors: The menus shall allow setup and display of optional custom sensors. The control shall include four customer accessible analog inputs for field-supplied sensors. The analog inputs shall accept a 4 to 20mA signal. The user shall be able to change the input to 0 to 5VDC or 0 to 10VDC. The gains for each analog input shall be programmable from the front display. The analog inputs shall be able to be monitored from the front display.

Diagnostics/Service Mode- The Liebert iCOM control shall be provided with self-diagnostics to aid in troubleshooting. The microcontroller board shall be diagnosed and reported as pass/not pass. Control inputs shall be indicated as On or Off at the front display. Control outputs shall be able to be turned On or Off from the front display without using jumpers or a service terminal. Each control output shall be indicated by an LED on a circuit board.

REMOTE TEMPERATURE & HUMIDITY SENSOR

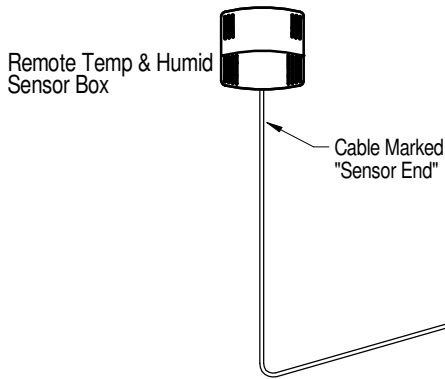
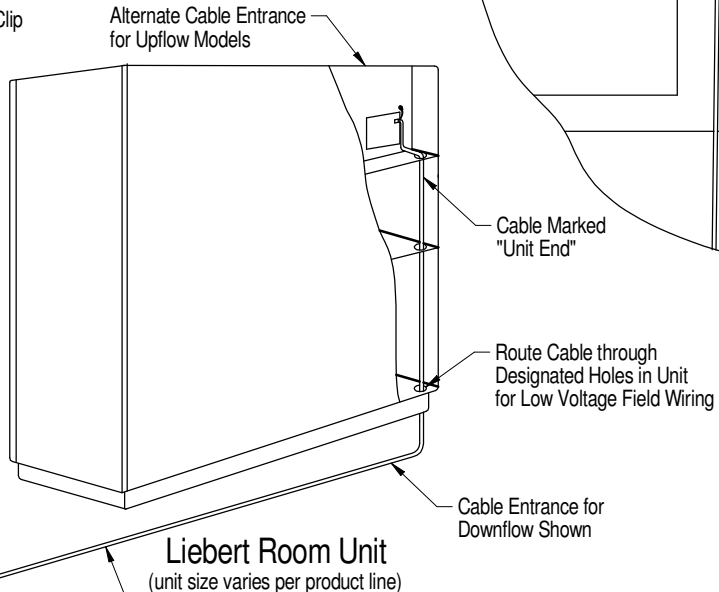
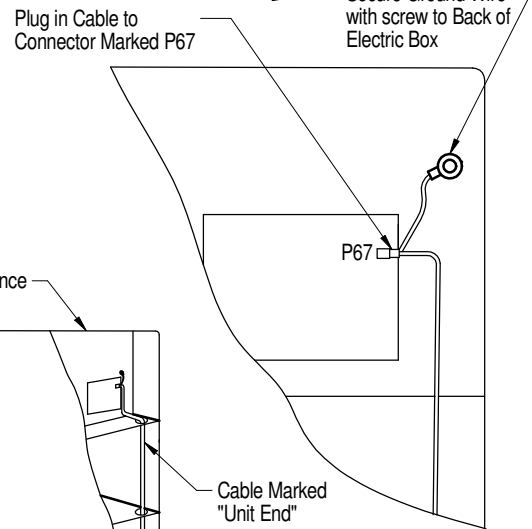
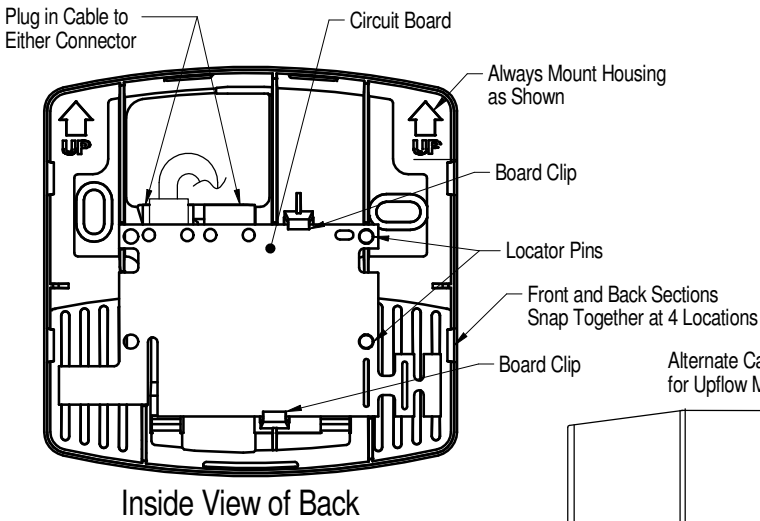
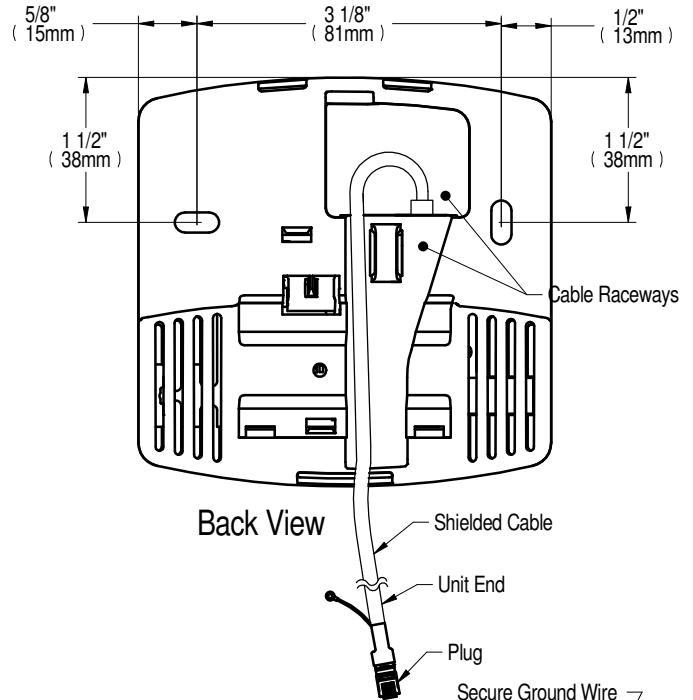
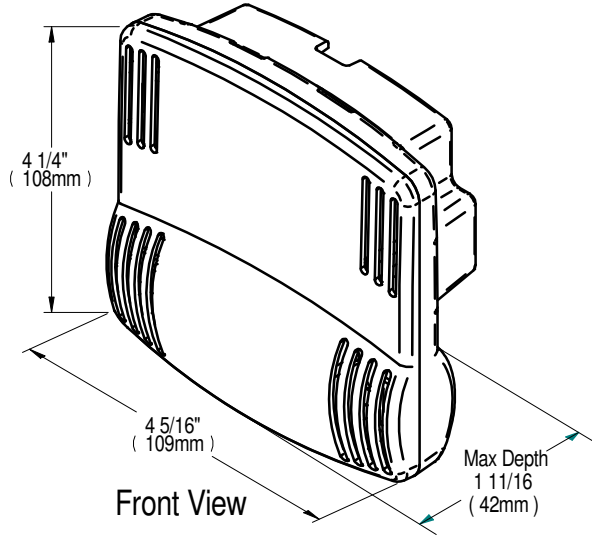

Factory supplied, field installed shielded cable. See specification sheet for length.

DISPLAY SERVICE BRACKET (OPTIONAL)

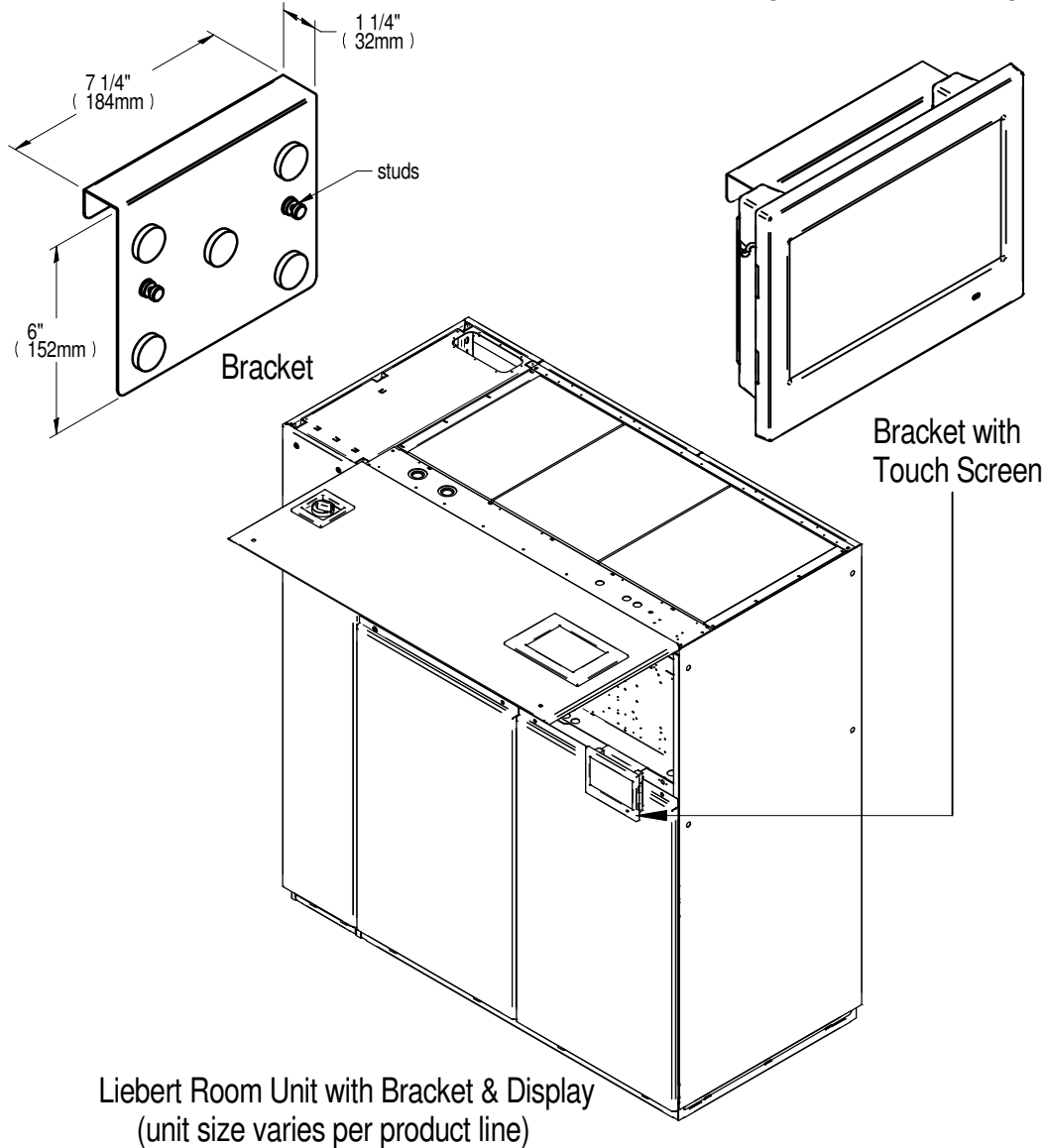

Liebert Room Unit with Bracket & Display
(unit size varies per product line)

PURPOSE: Bracket with display assembly may be hand held for adjustments. Bracket enables hanging the display between service tasks.

STEPS:

- 1) Verify that unit vertical panels are in place.
- 2) Unlatch display from cradle by pinching top tab while holding back of display - careful not to drop or let display hang by cables.
- 3) Align studs of bracket with keyholes on back of display.
- 4) Compress bracket and display at stud points together until bracket studs slide into slots of keyholes - careful not to pinch cables. There should be a tight fit once bracket is in place.
- 5) Hold display in hand to make adjustments.
- 6) Hang from lower edge of low voltage compartment between service tasks.
- 7) After use, remove and store bracket in tool box (do not store in electric panel).
- 8) Return Liebert iCOM™ display to cradle/bezel assembly.

CABINET & ANCHOR DIMENSIONAL DATA DP060 TOP INLET/FRONT SUPPLY

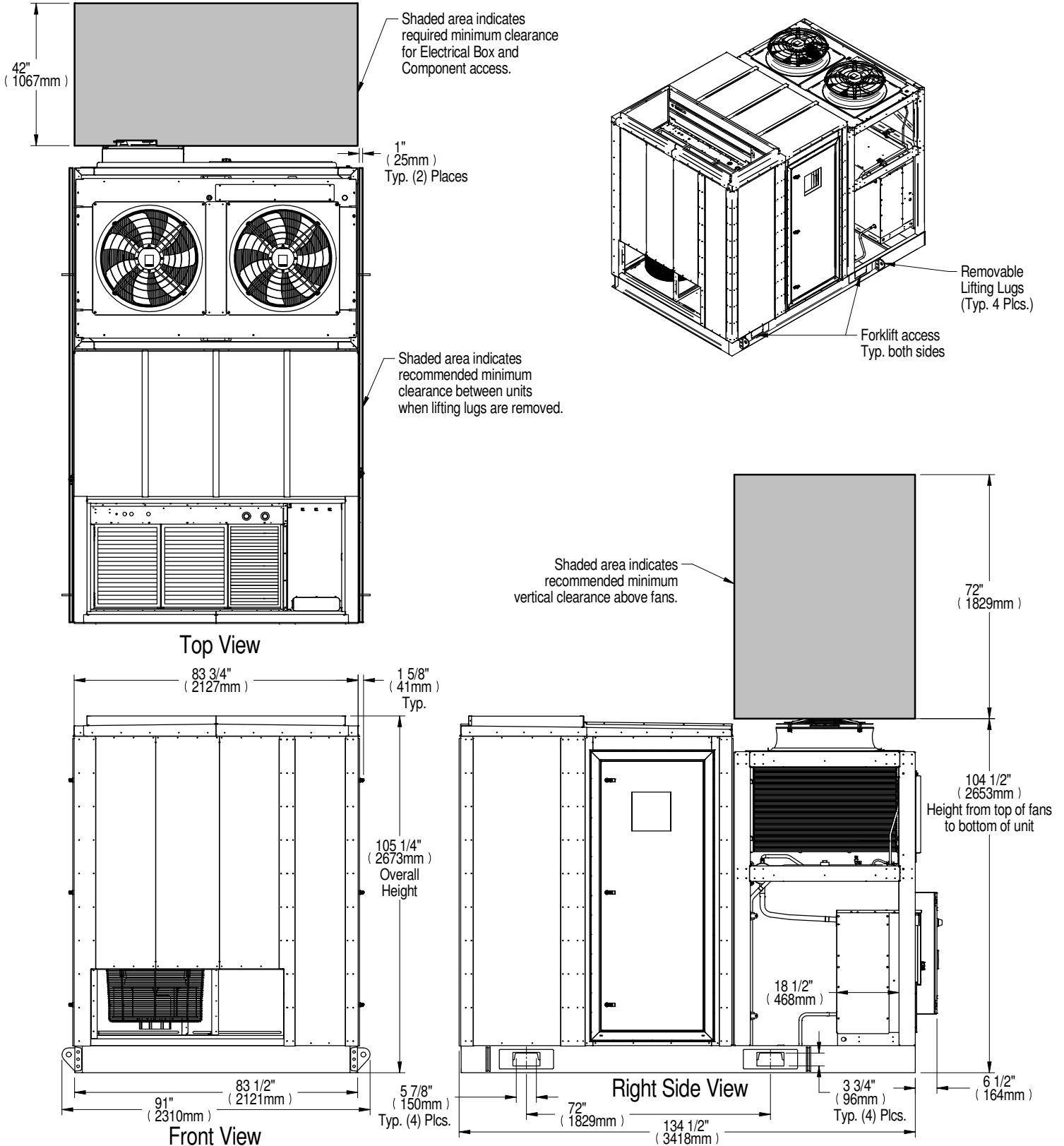

CABINET & ANCHOR DIMENSIONAL DATA DP060 TOP INLET/FRONT SUPPLY

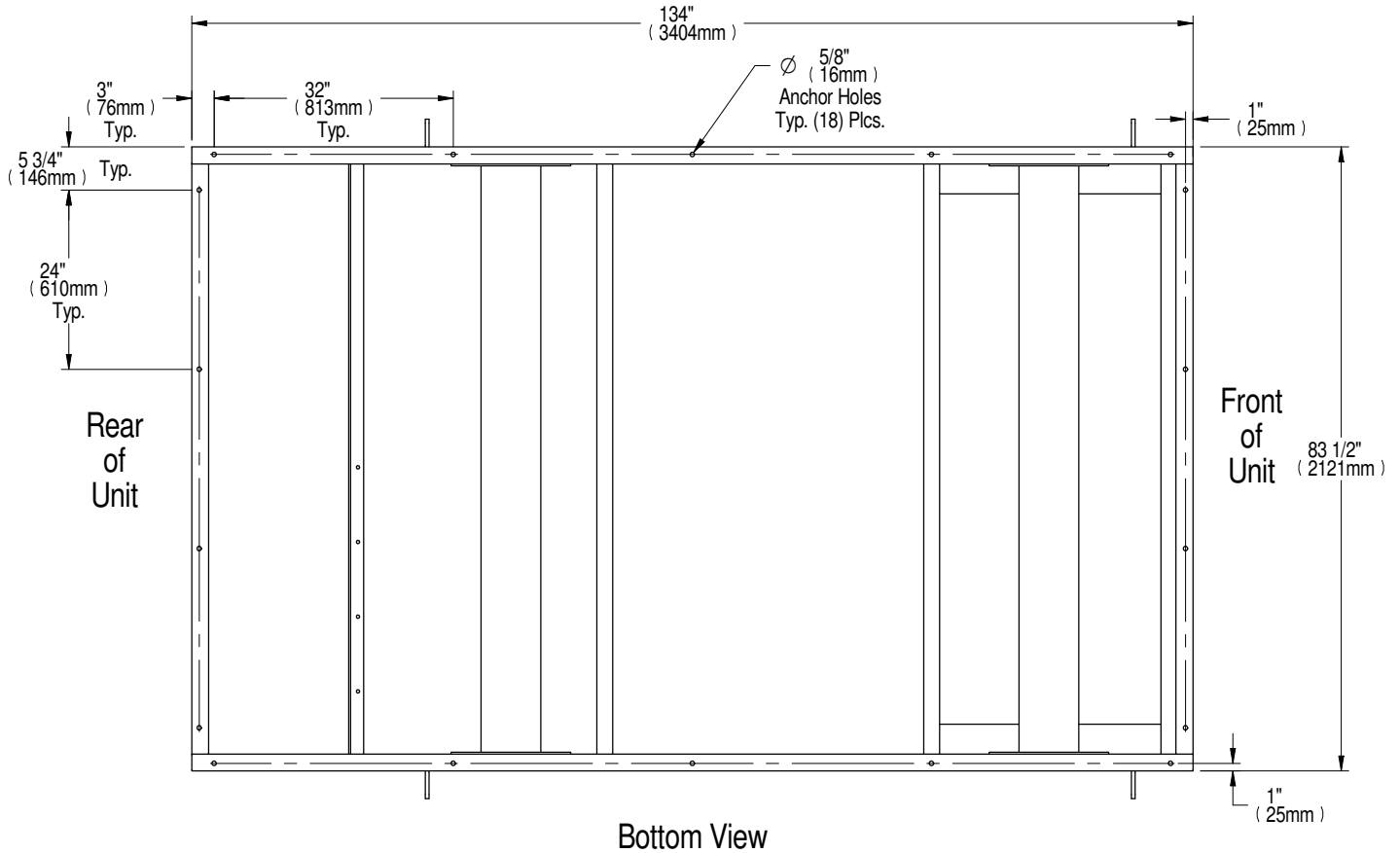

Bottom View

Notes:

1. Underside of base of unit. Components removed for clarity.
2. Mounting requirement details such as brand type, embedment depth, edge spacing, anchor spacing, concrete strength, wall bracing, and special inspection must be outlined and approved by the project Structural Engineer of Record.

EVAPORATOR DUCTING DIMENSIONAL DATA DP060 TOP INLET/FRONT SUPPLY

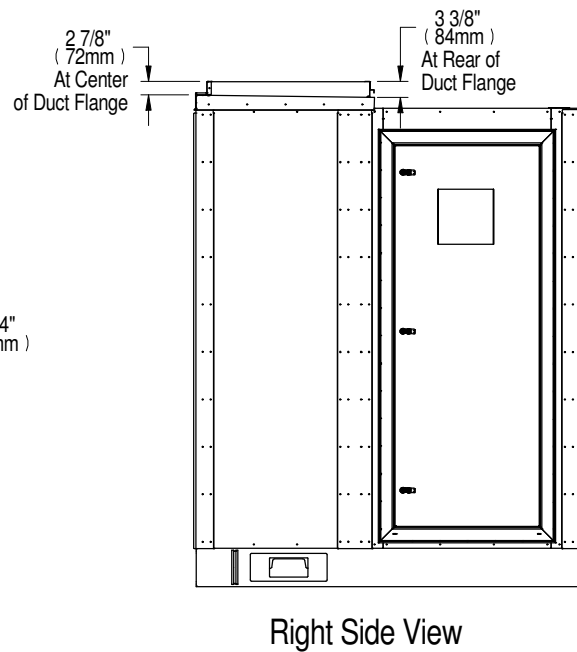
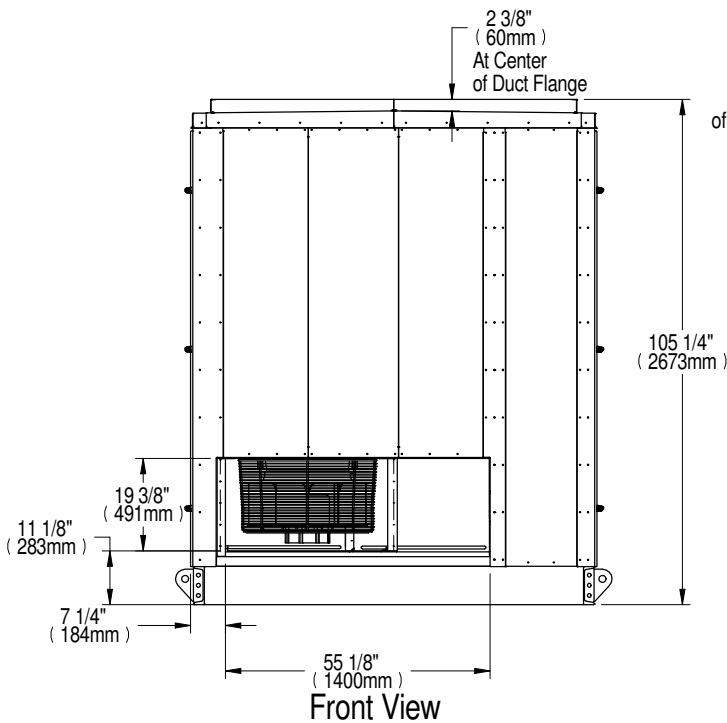
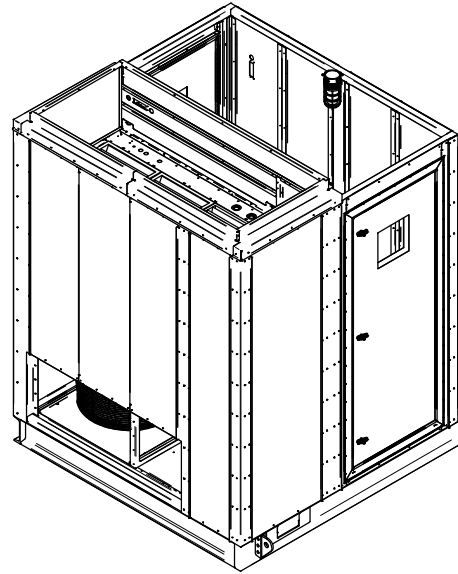
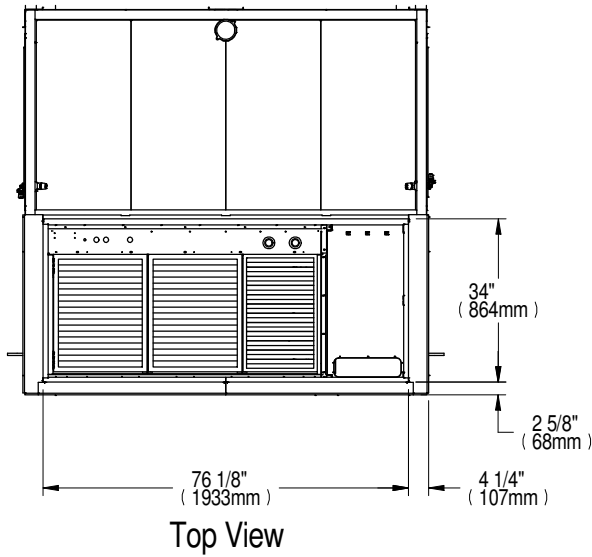

Notes:

1. Seal all ducts.

CONDENSATE DRAIN ACCESS & LOCATION DP060 PERIMETER UNIT

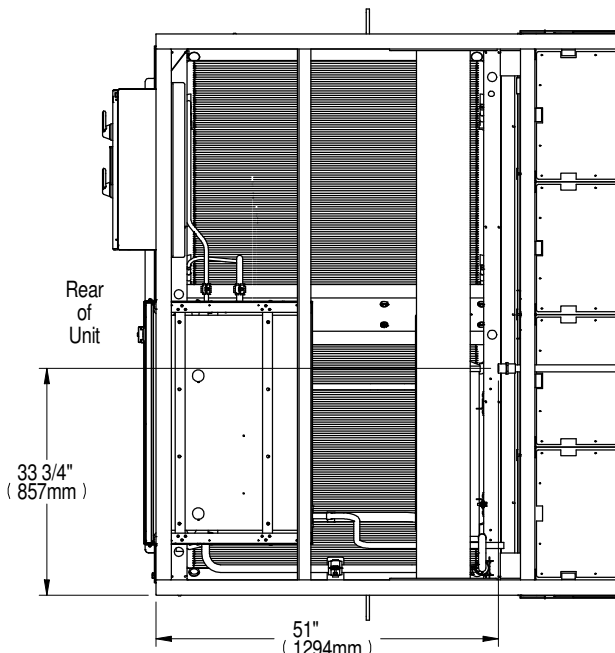
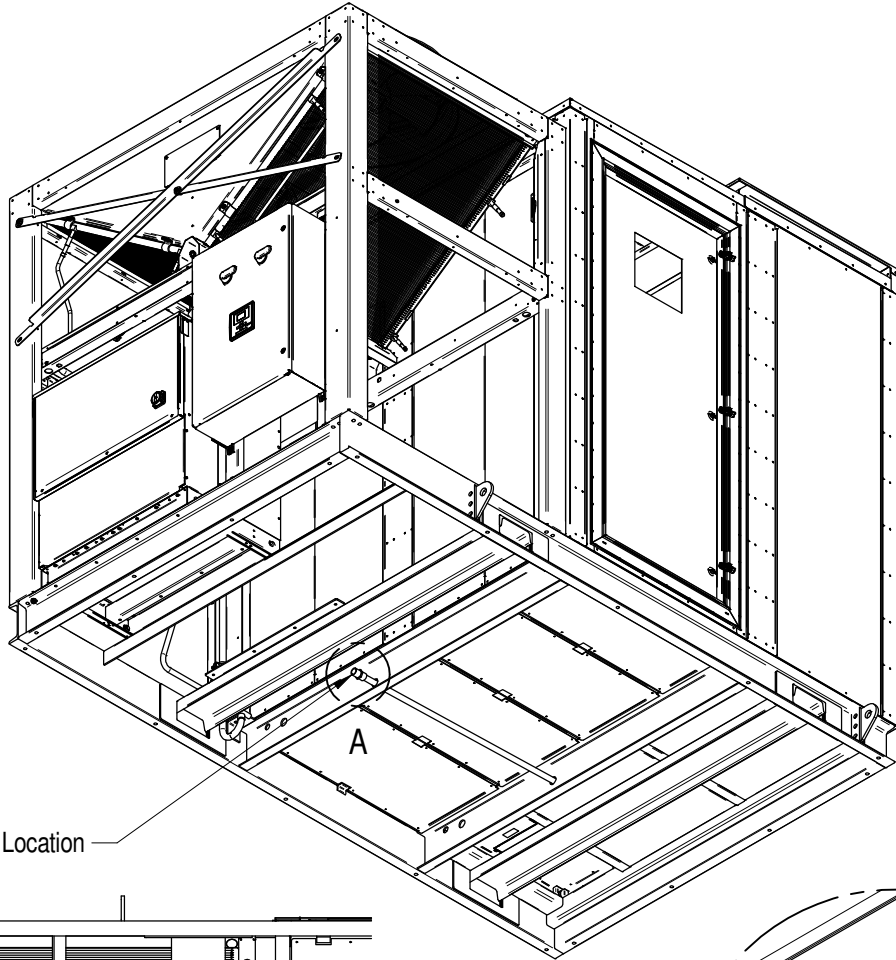

3/4" NPT female fitting
for Condensate Drain

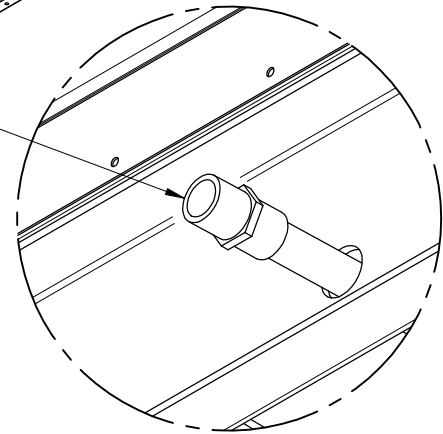

DETAIL A
Condensate Drain Location

Bottom View
showing Condensate Drain locating dimensions

EVAPORATOR COMPARTMENT SERVICE AREA DP060 TOP INLET/FRONT SUPPLY

Notes:

1.  Evaporator Coil is removed into service area and through either door. Requires 36" (914mm) X 60" (1524mm) clearance outside of door area.
2. **NOTICE:** Risk of equipment damage. Evaporator accent panel cannot be opened while exterior man door is closed.

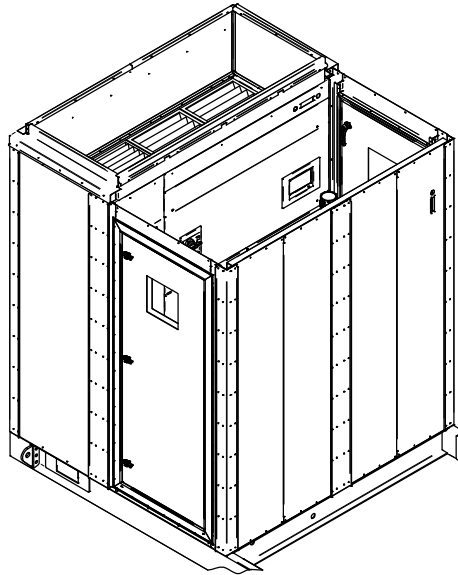

Access Door swings inward as shown (Typ. both sides)

 36" (914mm)

Shaded area indicates minimum clearance required in front of Liebert DSE unit.

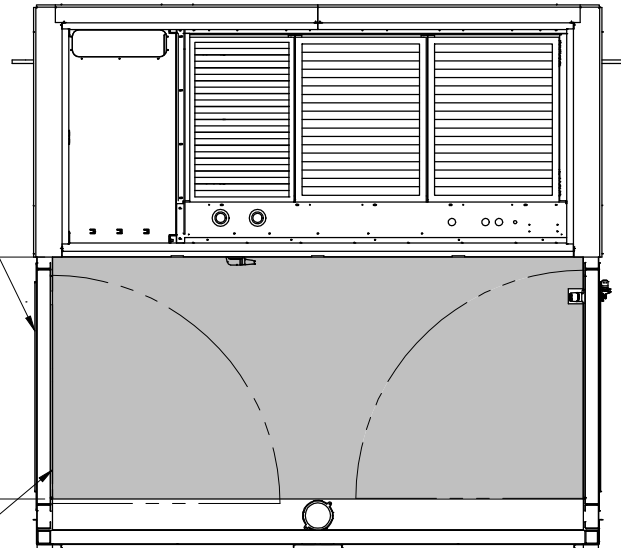

Top View of Evaporator Section

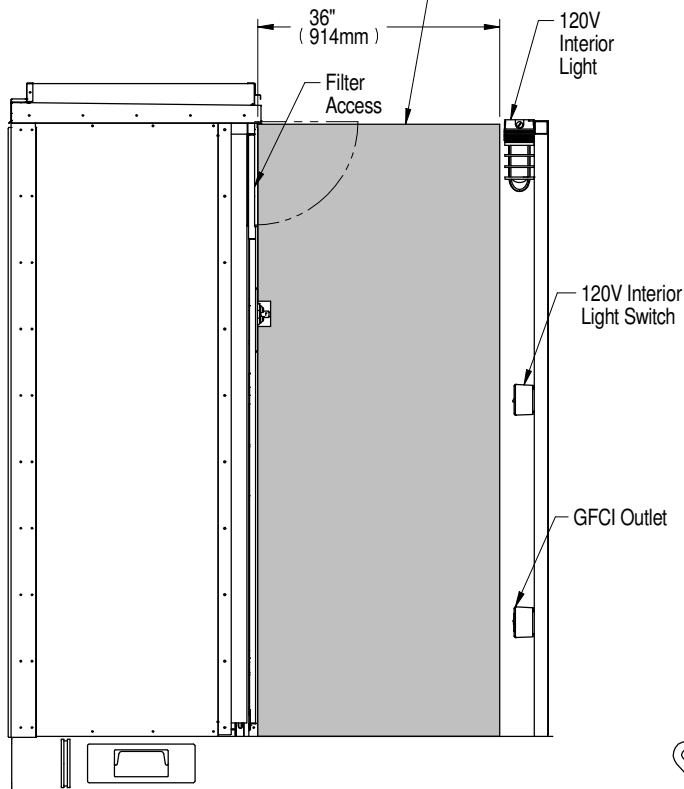

Side View of Evaporator Compartment
Access Door removed for clarity

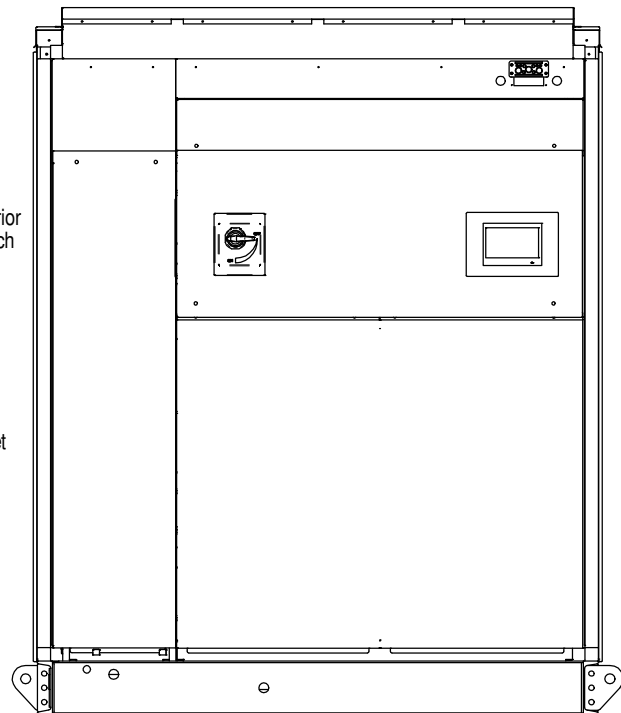

Front View of Evaporator Unit
Wall & Access Doors removed for clarity

INSTALLATION & SERVICE CLEARANCE DATA DP060

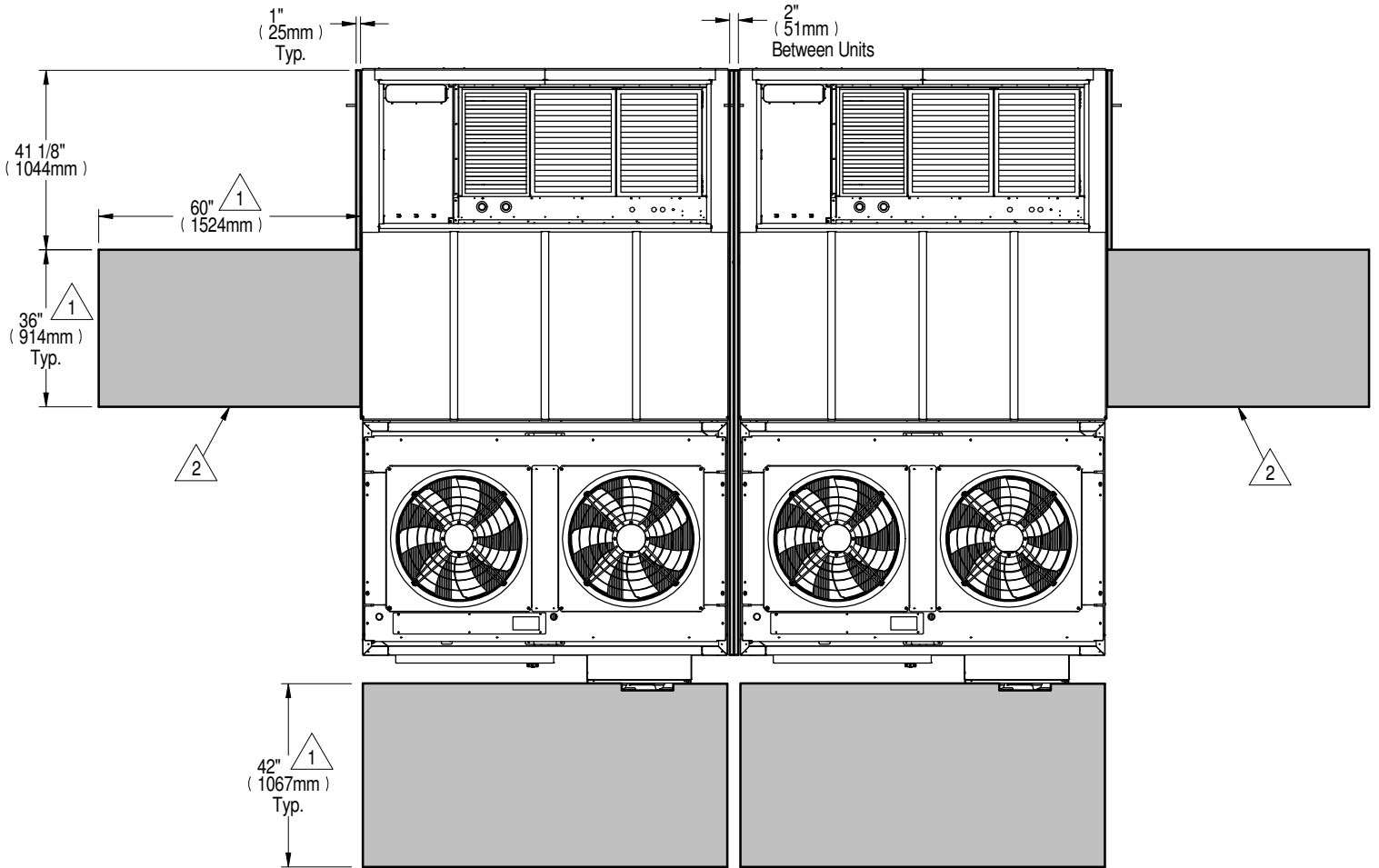

Top View
Rear of Units

Notes:

1. Required clearance between the end unit and the nearest obstruction.
2. Evaporator Coil may be removed into service area and through either door.
3. See DPN004600 for additional dimensional information.
4. Multiple units can be placed side by side. Two units shown for reference.

This page intentionally left blank

Appendix C: Guide Specifications

The following are the guide specifications for the Liebert® DP060.

Liebert® DSE™ 60-kW Packaged Solution

Guide Specifications

1.0 GENERAL

1.1 SUMMARY

These specifications describe requirements for a Thermal Management system. The system shall be designed to control temperature conditions in rooms containing electronic equipment, with good insulation and vapor barrier. The manufacturer shall design and furnish all equipment to be fully compatible with heat dissipation requirements of the room.

1.2 DESIGN REQUIREMENTS

The Thermal Management system shall be a Liebert outdoor packaged, factory-assembled unit for building perimeter application with top return air and front supply. Standard 60 Hz units shall be CSA-certified to the harmonized U.S. and Canadian product safety standard, CSA C22.2 No 236/UL 1995 for "Heating and Cooling Equipment" and are marked with the CSA c-us logo.

The system sensible coefficient of performance (SCOP) shall meet ASHRAE 90.1.

1.3 SUBMITTALS

Submittals shall be provided with the agreement of the proposal and shall include: Single-Line Diagrams; Dimensional, Electrical and Capacity Data; Piping; and Electrical Connection Drawings.

1.4 SERVICEABILITY/ACCESS

The unit shall be designed so that all components are easily accessible for service and maintenance through the front of the evaporator within the enclosure and front of the unit to access the condenser and PRE section. Evaporator enclosure may be accessed using one side door. Service or replacement of components through the data-center space shall not be allowed. To avoid contamination, the unit design shall allow washing of the condenser coils in place with no risk of water penetration to the data center area and without coming in contact with components that eventually will be in the data-center air flow.

1.5 ACCEPTABLE ALTERNATIVES

Acceptable alternatives shall be permitted with engineer's prior approval only. Contractor to submit a detailed summary form listing all variations to include size deviations, electrical load differences, functional and component changes, and savings to end user.

1.6 QUALITY ASSURANCE

The specified system shall be factory-tested before shipment. Testing shall include but shall not be limited to: Quality Control Checks, "Hi-Pot." The system shall be designed and manufactured according to world-class quality standards. The manufacturer shall be ISO 9001 certified.

2.0 PRODUCT

2.1 UNIT BASE

Manufacturer shall provide a full perimeter base frame to support entire unit. Base frame shall be fully welded made of structural "C" channel with anticorrosive paint finish or equal. Paint shall be able to withstand a salt spray test in accordance with ASTM B117 for a minimum of 1,000 consecutive hours. Multiple removable lifting points shall be integrated into base frame.

2.2 CASING

- Casing surrounding the data center air section including supply fan, filters, and evaporator coil shall be 2-in. R8 rockwool-insulated double wall panels with 16 ga. galvanized painted metal for exterior walls, 20-ga. galvanized metal on interior walls, and 16-ga. galvanized metal on roof and floor.
- Roof above the data center air section shall be single sloped away from the data center, standing seam.
- Liner of the panel shall have no contact with the exterior wall to provide a thermal break.
- Casing should be able to withstand 1.5 times the operating pressure or 6-inch w.g. whichever is less, with a deflection of no more than $L/240$.
- Doors shall be the same construction and thickness of the panels, include a window, and open away from evaporator unit.
- Exterior panel paint should be able to withstand a salt spray test in accordance with ASTM B117 for a minimum of 1,000 consecutive hours. Paint color shall be Liebert Pebble Gray (RAL 7032).
- Floor shall have 2-in., 1.8-lb insulation and include a bottom liner.

2.3 CONDENSING SECTION

The condenser cabinet shall contain fan and coil sections (single circuit). Internal structural support members, including coil support frame, shall be painted or galvanized steel for strength and corrosion resistance. An electrical panel shall be contained inside a factory mounted, NEMA 3R weatherproof electrical enclosure.

2.4 AIRFLOW CONFIGURATIONS

Unit shall be constructed for the dedicated configuration from the factory.

- Front supply – top return. Unit designed for building perimeter installation shall have the supply air on the lower level of the front side of the unit. The return air inlet shall be at the top of the unit to allow for a field manufactured return air plenum. The unit design should allow the unit installation as close to the building as the duct transition requires.

2.5 UNIT MOUNTING

- Unit designed for building perimeter installation shall be mounted on slab or steel base with the full base supported.

2.6 MAIN UNIT POWER

Main unit shall include a high-voltage distribution block with lockout/tagout capabilities. A separate, 120-V, customer-supplied power input is required for utility light and convenience outlets.

2.7 MAIN UNIT LOCKING DISCONNECT SWITCH

The manual locking disconnect switch shall be mounted in the main unit high-voltage section of the electrical panel. The switch shall be accessible from the outside of the unit with the door closed and shall prevent access to the high-voltage electrical components until switched to the OFF position.

2.8 SHORT-CIRCUIT CURRENT RATING (SCCR)

The electrical panel shall provide at least 65,000A SCCR (60 Hz).

Short-circuit current rating (SCCR) is the maximum short-circuit current a component or assembly can safely withstand when protected by a specific overcurrent protective device(s) or for a specified time.

3.0 EVAPORATOR COMPARTMENT

3.1 FRAME

The frame shall be welded, formed sheet metal. It shall be protected against corrosion using the autophoretic coating process.

3.2 AIR-SUPPLY CONFIGURATIONS

3.2.1 Perimeter—Top Return, Face Supply

The supply air shall exit from the face (front) of the unit. The return air shall enter the evaporator section through top. Field-supplied duct connections are required for supply and return.

3.3 EVAPORATOR PANELS

The evaporator panels shall be insulated with a minimum 2 in. (25.4 mm), 1.8 lb. (0.68 kg) density fiber insulation. The front panel shall have captive quarter-turn fasteners. The evaporator panel color shall match the enclosure color.

3.4 FILTERS—60KW

The filter chamber shall be located within the plenum section above the evaporator, and filters shall be serviceable through the filter-plenum service-access door.

3.4.1 4-in. MERV8 or MERV11

Filters shall be deep-pleated, 4 in. (102 mm) filters with an ASHRAE 52.2-2007 MERV8 or MERV11 rating.

3.4.2 Extra Filter Set

___ extra set(s) of filters shall be provided per system

3.5 LOCKING DISCONNECT SWITCH

The manual disconnect switch shall be mounted in the high-voltage section of the evaporator electrical panel. When inside the evaporator compartment, the switch shall be accessible on the front of the evaporator with its electric panel closed. It shall prevent access to the high-voltage electrical components inside the evaporator until switched to the OFF position.

3.6 SHORT-CIRCUIT CURRENT RATING (SCCR)

The electrical panel shall provide at least 65,000A SCCR (60 Hz).

Short-circuit current rating (SCCR) is the maximum short-circuit current a component or assembly can safely withstand when protected by a specific overcurrent protective device(s) or for a specified time.

3.7 EVAPORATOR FAN SECTION

3.7.1 Electronically Commutated (EC) Fans

The fan shall be plug/plenum type, motorized impellers, single inlet and dynamically balanced. The drive package shall be direct drive, electronically commutated and variable speed. The fan shall be located to draw air over the coil to ensure even air distribution and maximum coil performance.

Fan motor shall be nominal 3.7 hp (2.8 kW) with a maximum operating speed of 1400 RPM.

3.7.2 EC Fan Overload

The EC fan fault is standard on all models.

3.8 REFRIGERATION SYSTEM

3.8.1 Single Circuit

Each unit shall include one factory-piped refrigeration circuit and shall include a liquid-line filter drier, refrigerant sight glass with moisture indicator and electronic expansion valve. Compressor shall be located outside the air stream and shall be removable and serviceable from the front of the evaporator section.

3.8.2 Compressor

3.8.2.1 DIGITAL SCROLL COMPRESSOR

The compressor shall be scroll-type with a variable capacity operation capability via compressor solenoid valve. The compressor shall have vibration isolators, thermal overloads, automatic reset high-pressure switch with lockout after three failures, rotalock service valves, suction line strainer and a maximum operating speed of 3500 rpm. The compressor motor shall be suction gas cooled.

3.8.2.2 COMPRESSOR OVERLOAD

A pair of N/O contacts shall be factory-installed and wired to each compressor to indicate Compressor Overload.

3.8.2.3 CRANK-CASE HEATERS

The compressor shall include crankcase heater, powered from the evaporator-section electric panel.

3.8.3 Evaporator Coil

The evaporator coil shall be A-frame design and have _____ sq. ft. (_____ sq. m) face area, ____ rows deep. It shall be constructed of rifled copper tubes and aluminum fins with a maximum face velocity of _____ ft. per minute (_____ m/s) at _____ CFM (_____ CMH). A stainless-steel condensate drain pan shall be provided.

3.8.4 R-410A Refrigerant

The system shall be designed for use with R-410A refrigerant, which meets the U.S. Clean Air Act for phase-out of HCFC refrigerants. Unit is factory pre-charged with refrigerant.

4.0 HEAT REJECTION

4.1 CONDENSER SECTION

The air-cooled condenser section shall provide positive refrigerant head pressure control to the evaporating coil by adjusting heat rejection capacity. Microchannel coils shall provide superior heat transfer, reduce air-side pressure drop, increase energy efficiency and significantly reduce the system refrigerant volume required. EC fans and fan operating techniques shall provide reduced maximum sound levels.

4.1.1 Condenser Coils

Microchannel coils shall be constructed of aluminum microchannel tubes, fins and manifolds. Tubes shall be flat and contain multiple, parallel flow microchannels and span between aluminum headers. Full-depth louvered aluminum fins shall fill spaces between the tubes. Tubes, fins and aluminum headers shall be oven brazed to form a complete refrigerant-to-air heat exchanger coil. Copper stub pipes shall be electric resistance welded to aluminum coils and joints protected with polyolefin to seal joints from corrosive environmental elements. Coil assemblies shall be factory leak-tested at a minimum of 300 psig (2068kPag). The unit is factory piped.

4.1.2 Condenser Fan

The fan motor/blade assembly shall have an external rotor motor, fan blades and fan/finger guard. Fan blades shall be constructed of cast aluminum or glass-reinforced polymeric material. Fan guards shall be heavy gauge, close meshed steel wire, coated with a black corrosion resistant finish. Fan terminal blocks shall be located in an IP54 enclosure located on the top of the fan motor. Fan assemblies shall be factory-balanced, tested before shipment and mounted securely to the condenser structure.

4.1.3 EC Fan Motor

The EC Fan motors shall be electronically commutated for variable speed operation and shall have ball bearings. The EC fans shall provide internal overload protection through built-in electronics. Each EC fan motor shall have a built-in controller and communication module, linked via RS485 communication wire to each fan and the Premium Control Board, allowing each fan to receive and respond to precise fan speed inputs from the Premium Control Board.

4.1.4 Refrigerant Receiver

The refrigerant circuit shall contain a painted, uninsulated receiver with integral fusible plug and connected to the condenser liquid line.

4.1.5 Condenser Electronic Controls

Electrical controls and service connection terminals shall be provided, and factory wired inside the control panel section of the PRE unit. The condenser control system shall include an electronic control board, EC fan motor(s) with internal overload protection, refrigerant and ambient temperature thermistors, and refrigerant pressure transducers. The condenser control board shall communicate directly with the unit's Liebert iCOM™ control via CANbus communication and low-voltage interlock wires. The control board shall use sensor and communication inputs to maintain refrigerant pressure by controlling each EC fan on the same refrigerant circuit to the same speed. The condenser control system shall be rated to a temperature of –30°F to 125°F (–34.4°C to 51.7°C) and shall be factory-set for fan speed control with Liebert DSE receivers.

The mode of the condenser control board shall be controlled by the Liebert iCOM™ control and shall be in either DX, Liebert EconoPhase™ or Idle Mode by each refrigerant circuit. Fan(s) on common refrigerant circuit shall operate in synchronous speed when that circuit is active.

4.1.6 EconoPhase Cycle

During cold outdoor temperatures, refrigerant pumps shall circulate refrigerant through the cooling system, in lieu of operating the compressors. The compressors shall ramp down during EconoPhase operation, and, if able to completely offset the load, the control system shall shut the compressors off. Refrigerant pump(s) shall be housed in an enclosure, with each pump dedicated to its own refrigerant circuit. The EconoPhase system shall include a variable-speed drive on each refrigerant pump to enable the pumps' speed to adjust in response to the load.

4.1.7 EconoPhase/Condenser Locking Disconnect Switch

The manual disconnect switch shall be mounted in the high-voltage section of the EconoPhase electrical panel. The switch shall be accessible from the outside of the unit with the door closed and shall prevent access to the high-voltage electrical components until switched to the OFF position.

5.0 CONTROLS

5.1 LIEBERT ICOM™ MICROPROCESSOR CONTROL WITH 7-IN COLOR TOUCHSCREEN

The Liebert iCOM shall be microprocessor-based with a 7-in. color touchscreen display and shall be mounted in an ergonomic, aesthetically pleasing housing. The display and housing shall be viewable while the front panel is open or closed. The controls shall be menu driven. The system shall display user menus for active alarms, event log, graphic data, unit view/status overview (including the monitoring of room conditions, operational status in percentage of each function, date and time), total run hours, various sensors, display setup and service contacts. A password shall be required to make system changes. Service menus shall include setpoints, standby settings (lead/lag), timers/sleep mode, alarm setup, sensor calibration, maintenance/wellness settings, options setup, system/network setup, auxiliary boards and diagnostics/service mode. The Liebert iCOM control shall provide Ethernet/RS-485 ports dedicated for BMS connectivity (i.e. Base-Comms).

- Password Protection – The Liebert iCOM shall contain two unique passwords to protect against unauthorized changes. An auto hide/show feature allows the user to see applicable information based on the login used.
- Unit Backup and Restore – The user shall be able to create safe copies of important control parameters. The Liebert iCOM shall have the capacity for the user to automatically backup unit configuration settings to internal memory or USB storage drive. Configuration settings may be transferred to another unit for a more streamlined unit startup.
- Parameter Download – The Liebert iCOM shall enable the user to download a report that lists parameter names, factory default settings and user-programmed settings in .csv format for remote reference.
- Parameter Search – The Liebert iCOM shall have search fields for efficient navigation and parameter lookup.
- Parameter Directory – The Liebert iCOM shall provide a directory that lists all parameters in the control. The list shall provide Line ID numbers, parameter labels, and current parameter values.
- Context-Sensitive Help – The Liebert iCOM shall have an on-board help database. The database shall provide context sensitive help to assist with setup and navigation of the menus.
- Display Setup – The user shall have the ability to configure the Liebert iCOM information based on the specific user's preference. Language, units of measure, screen contrast, home screen layout, back-light timer and the hide/show of certain readouts shall be configurable through the display.
- Additional Readouts – The Liebert iCOM shall permit the user to configure custom widgets on the main screen. Widget options shall include items such as fan speed, call for cooling, call for free-cooling, maintenance status, call for hot water reheat, call for electric reheat, call for dehumidification, call for humidification, airflow, static pressure, fluid flow rate and cooling capacity.
- Status LEDs – The Liebert iCOM shall provide the user with the unit's operating status using an integrated LED. The LED shall indicate if the unit has an active alarm; if the unit has an active alarm that has been acknowledged; or if the unit is On, Off or in standby status.
- Event Log – The Liebert iCOM shall automatically store the last 400 unit-only events (messages, warnings, and alarms).
- Service Contact Information – The Liebert iCOM shall have the ability to store the local service or sales contact information.
- Upgradeable – Liebert iCOM upgrades shall be performed through a USB connection.
- Timers/Sleep Mode – The menu shall allow various customer settings for turning unit On or Off.

- Menu Layout – The menus shall be divided into two main menus: User and Service. The User screen shall contain the menus to access parameters required for basic unit control and setup. The Service screen shall be designed for service personnel and shall provide access to advanced control setup features and diagnostic information.
- Sensor Calibration – The menus shall allow unit sensors to be calibrated with external sensors.
- Maintenance/Wellness Settings – The menus shall allow reporting of potential component problems before they occur.
- Options Setup – The menus shall provide operation settings for the installed components.
- Auxiliary Boards – The menus shall allow setup of optional expansion boards.
- Various Sensors – The menus shall allow setup and display of optional custom sensors. The control shall include four customer-accessible analog inputs for sensors provided by others. The analog inputs shall accept a 4 to 20mA signal. The user shall be able to change the input to 0 to 5VDC or 0 to 10VDC. The gains for each analog input shall be programmable from the front display. When configured, the analog inputs shall be able to be monitored from the front display.
- Diagnostics/Service Mode – The Liebert iCOM™ control shall be provided with self-diagnostics to aid in troubleshooting. The microcontroller board shall be diagnosed and reported as pass/not pass. Control inputs shall be indicated as On or Off at the front display. Control outputs shall be able to be turned On or Off from the front display without using jumpers or a service terminal. Each control output shall be indicated by an LED on a circuit board.
- Base-Comms for BMS Connectivity – The Liebert iCOM controller shall provide one Ethernet Port and RS-485 Port dedicated for BMS Connectivity. Provides ground fault isolated RS-485 Modbus, BACnet IP & Modbus IP network connectivity to Building Management Systems for unit monitoring and management. Also, provides ground fault isolated 10/100 baseT Ethernet connectivity for unit monitoring and management. The supported management interfaces include SNMP for Network Management Systems, HTTP for web page viewing, SMTP for email, and SMS for mobile messaging. The iCOM controller can support dual IP on a single network and one 485 protocol simultaneously.
- DSE System Optimization – Allows for efficiency improvements for the DSE system during EconoPhase mode. By optimizing liquid refrigerant temperature and pressure setpoints, the result is a reduction in power consumption of the condenser fan during mid and high ambient conditions. DSE System Optimization provides an opportunity for additional energy savings by increasing the utilization of the PRE-pumps and decreasing the utilization of the condenser fans, but always maintaining appropriate heat capacity rejection during mid to high ambient outdoor conditions. Energy savings occur when utilizing the PRE-pump package; a pump consumes roughly 1/10th of the power consumed by the compressor.

5.2 ALARMS

All unit alarms shall be annunciated through both audio and visual cues, clearly displayed on the screen, automatically recorded in the event log and communicated to the customer's Building Management System/Building Automation System. The Liebert iCOM control shall activate an audible and visual alarm in the event of any of the following conditions:

- High Temperature
- Low Temperature
- High Humidity
- Low Humidity
- EC Fan Fault
- Change Filters
- Loss of Air Flow
- Loss of Power
- Compressor Overload (Standard on 60 kW)
- High Head Pressure
- Low Suction Pressure
- Custom Alarms
- Custom alarm inputs shall be provided to indicate facility-specific events. Custom alarms can be identified with programmable labels. Frequently used alarm inputs shall include:
 - Leak Under Floor
 - Smoke Detected
 - Standby Unit On

Each alarm (unit and custom) shall be separately enabled or disabled, selected to activate the common alarm and programmed for a time delay of 0 to 255 seconds.

5.2.1 Liebert iCOM™ Control Methods and Options

The Liebert iCOM shall be factory-set to allow precise monitoring and control of the condition of the air entering and leaving the unit. This control shall include predictive methods to control air flow and cooling capacity-based control sensors installed. Proportional and Tunable PID shall also be user-selectable options.

5.2.2 Controlling Sensor Options

The Liebert iCOM shall be flexible in the sense that it shall allow for control of the capacity and fan from multiple different sensor selections. The sensor selections shall be:

Cooling Capacity

- Supply
- Remote
- Return

Fan Speed

- Supply
- Remote
- Return
- Manual (for diagnostics or to receive a signal from the BMS through Liebert remote monitoring devices or analog input)
- Static Pressure

5.2.3 Temperature Compensation

The Liebert iCOM™ shall be able to adjust the capacity output based on supply and return temperature conditions to meet SLA guidelines while operating at highest efficiency.

5.3 MULTI-UNIT COORDINATION

Liebert iCOM teamwork shall save energy by preventing multiple units in an area from operating in opposing modes. Teamwork allows the control to optimize a group of connected thermal-management units with Liebert iCOM using the U2U (Unit-to-Unit) network. There shall be two modes of teamwork operation:

- Teamwork Mode 2 (Independent) – The Liebert iCOM calculates the worse-case demand for heating, cooling humidification and dehumidification. Based on the greatest demand within the group, each unit operates independently, meaning that the unit may respond to the thermal load and humidity conditions based on the units controlling sensors. All sensor readings are shared.
- Teamwork Mode 3 (Optimized Aisle) – May be employed in large and small rooms with varying heat loads. Optimized Aisle is the most efficient teamwork mode that allows the unit to match cooling capacity with heat load. In the Optimized Aisle mode, the fans operate in parallel. Fans can be controlled exclusively by remote temperature or using static pressure with a secondary remote temperature sensor(s) as an override to ensure that the inlet rack temperature is being met. Cooling (Compressors, Economizer or EconoPhase) is controlled based on unit supply-air conditions. The Liebert iCOM calculates the average or worst-case sensor reading (user-selectable) for heating, cooling humidification and dehumidification. Based on the demand within the group, units will be allowed to operate within that mode until room conditions are satisfied. This is the best form of control for a room with an unbalanced load.

5.4 STANDBY/LEAD-LAG

The Liebert iCOM shall allow scheduled rotation to keep equal run time on units and provide automated emergency rotation of operating and standby units.

5.5 STANDBY UNIT CASCADING

The Liebert iCOM cascade option shall allow the units to turn On and Off based on heat load when utilizing Teamwork Mode 3 – Optimized Aisle mode with remote temperature sensors. In Teamwork Mode 3, Cascade mode will stage units On based on the temperature and humidity readings and their deviation from setpoint. Cascade mode coordinates the fan speed dynamically to save energy and to meet the cooling demands. For instance, with a Liebert iCOM group of six units and only 50% of the heat load, the Liebert iCOM shall operate only four units at 80% fan speed and leave the other two units in standby. As the heat load increases, the Liebert iCOM shall automatically respond to the additional new load and bring on another unit, increasing the units in operation to five. As the heat load shifts up or down, the control shall meet the needs by cascading units On or putting them back into standby.

5.6 VIRTUAL MASTER

As part of the robust architecture of the Liebert iCOM control, it shall allow for a virtual master that coordinates operation. The Virtual Master function shall provide smooth control operation if the group's communication is compromised. When the lead unit, which is in charge of component staging in teamwork, unit staging and standby rotation, becomes disconnected from the network, the Liebert iCOM shall automatically assign a virtual master. The virtual master shall assume the same responsibilities as the master until communication is restored.

5.7 VIRTUAL BACK-DRAFT DAMPER

The Liebert iCOM shall allow the use of a virtual back-draft damper, eliminating the need for a mechanical damper. This shall allow the fans of a stand-by unit to spin slower (15% or less) to act as a damper.

5.8 COMPRESSOR SHORT CYCLE CONTROL

Compressor short cycle control shall be available to prevent compressor short-cycling and needless compressor wear.

5.9 LIEBERT MC™AND ECONOPHASE COMMUNICATION

The Liebert iCOM shall communicate directly with the Liebert MC condenser and Liebert EconoPhase unit via factory wired CANbus communication wires and low-voltage interlock wires. This communication shall allow Liebert iCOM to control Liebert MC condenser/EconoPhase modes and operation and to monitor their health and alarm status.

5.10 WIRED SUPPLY SENSOR

A factory-installed and commissioned supply-air sensor ships with the unit for sensor location in the field by others when supply-air control is required. The sensor is terminated on the Liebert iCOM unit-controller terminal strip and the 20-ft. (6-m) associated cable wiring is coiled within the unit for shipment, requiring others to locate the sensor in accordance with acceptable best practices and any local codes. The relocated supply-air temperature sensor provides real-time, direct feedback to the cooling unit, allowing the unit to adjust compressor capacity or chilled-water valve accordingly to maintain supply-air temperature setpoint. It is recommended that if relocating the supply-air sensor, that it be mounted 10 to 15 ft. away from the unit directly in the discharge air stream. The supply-air temperature sensor, if left inside the unit, will provide real-time monitoring of discharge air temperature on units, such as downflow units with floor-level discharge and upflow units with discharge-grille plenums.

5.11 SYSTEM AUTO RESTART

The auto restart feature shall automatically restart the system after a power failure. Time delay shall be programmable. An optional capacitive buffer may be provided for continuous control operation through a power outage.

5.12 SEQUENTIAL LOAD ACTIVATION

On initial startup or restart after power failure, each operational load shall be sequenced with a minimum of one second delay to minimize total inrush current.

5.13 LOW-PRESSURE MONITORING

Units shall ship standard with low-pressure transducers for monitoring individual compressor suction pressure. If the pressure falls due to loss of charge or other mechanical cause, the corresponding circuit shall shut down to prevent equipment damage. The user shall be notified of the low-pressure condition through the local display and remote monitoring.

5.14 WINTER START TIME DELAY

An adjustable software timer shall be provided to assist with compressor starting during cold weather. When the compressor starts, the low-pressure input shall be ignored for the period set in the user-adjustable timer. Once the delay after the compressor start has elapsed, the low-pressure input should remain in the normal state. If the low-pressure input does not remain in the normal state after the delay has elapsed, the circuit shall lock out on low pressure. The low-pressure alarm shall be announced on the local display and communicated to remote monitoring systems.

5.15 ADVANCED FREEZE PROTECTION

Units shall ship standard with advanced freeze protection enabled. The advanced freeze protection shall monitor the pressure of each circuit using a transducer. The control shall interact with the fan and compressor to prevent the unit coil from freezing if circuit suction pressure drops. Applying fan speed to direct expansion systems requires limitations to avoid freezing condensate on the coil when the unit operates below 100% fan speed. Liebert iCOM's advanced freeze protection provides the ability to predict freeze conditions and correct this condition automatically by adjusting fan speed and compressor capacity. If a freeze condition is detected, the user shall be notified through the local display and remote monitoring systems.

5.16 ADVANCED HIGH-PRESSURE PROTECTION

When the compressor is initially activated, the system shall be monitored for a high pressure. When high pressure is detected, the control shall reduce the system discharge pressure by altering the compressor loading and the condenser fan speed, preventing circuit shut down. If the unit is unsuccessful in correcting the problem through this interaction, an alarm shall occur, and the affected compressor shall be immediately locked off. The control shall automatically re-enable the compressor when pressure returns to a safe level.

5.17 REFRIGERANT PRESSURE TRANSDUCER FAILURE

The control shall monitor the high-side and low-side refrigerant pressure transducers. If the control senses that the transducer has failed, has been disconnected, shorted or the reading has gone out of range, the user shall be notified through the local display and remote monitoring. The corresponding circuit that the failure has occurred on shall be disabled to prevent unit damage.

5.18 OIL RETURN PROTECTION

The control shall monitor compressor operation and staging to ensure that liquid and hot gas velocity are maintained for proper oil return to the compressor.

5.19 DIGITAL SCROLL HIGH-TEMPERATURE PROTECTION

The control shall monitor digital scroll temperature during unit operation. A compressor temperature limit shall be imposed to help prevent damage to the compressor. If the temperature reaches the maximum temperature limit, the compressor shall be locked out for 30 minutes and an alarm shall be annunciated on the local display and through monitoring. After the initial lockout, the control shall continue to monitor compressor temperature during the off-cycle and re-enable the circuit once a safe operating temperature is reached and the 30 minutes has elapsed. The control shall store the number of high-temperature trips. The number of trips shall be accessible through the local display.

5.20 DIGITAL SCROLL SENSOR FAILURE

The control shall monitor the status of the digital scroll sensor(s). If the control senses that the thermistor becomes disconnected, shorted or the reading goes out of range, the user will be notified through an event on the local display and remote monitoring.

5.21 COMPRESSOR HIGH- AND LOW-TEMPERATURE LIMIT PROTECTION

The control shall monitor the return air to ensure that the compressor is operated within the manufacturer's defined window of operation. If the return air temperature deviates from the manufacturer's window of operation, the Liebert iCOM shall automatically adjust to prevent damage to the cooling unit or reduction in its reliability.

5.22 COMPRESSOR RUN TIME MONITORING

The control shall log these compressor statistics:

- Number of compressor starts
- Run hours
- Average run time
- Starts per day
- Starts per day worst
- Number of high-pressure alarms
- Operating phase in which the high-pressure alarm occurred
- Number of low-pressure alarms
- Operating phase in which the low-pressure alarm occurred
- Number of compressor overloads
- Number of high-temperature alarms (scroll compressors)

The user shall have the ability to monitor compressor operating temperature and pressure from the local display to be used as a diagnostic tool.

5.23 MANUAL COMPRESSOR DISABLEMENT

The user shall have the ability to disable compressor operation using a set of either normally-open or normally-closed dry contacts tied directly to the control or through remote monitoring. An additional enable/disable feature shall be provided to allow the user to permanently disable an individual compressor circuit for maintenance using the local display.

5.24 LOW VOLTAGE TERMINAL PACKAGE

Factory-installed and factory-wired terminals shall be provided.

- Remote Shutdown Terminals – 2 additional pairs of terminals provide the customer with additional locations to remotely shut-down the unit by field-installed devices or controls.
- Extra Common-Alarm Contacts – 2 additional pairs of terminals provide the customer with normally-open contacts for remote indication of unit alarms.
- Main-Fan Auxiliary Switch – 1 set of normally-open contacts wired to the EC-fan motor contactor will close when EC-fan operation is required. This set of dry contacts could also be used to initiate air economizer operation. Air economizer and associated devices by others.
- Liqui-tect Shutdown – 1 pair of dry contacts for the Liqui-tect sensor signal will provide unit shut down. (Liqui-tect sensor is not included.)

5.25 REMOTE HUMIDIFIER CONTACT

A pair of N/O contacts provided for connection to a remote humidifier that allows the unit's humidity controller to control a humidifier outside the unit. Power to operate the remote humidifier does not come from the unit.

6.0 MISCELLANEOUS OPTIONS

6.1 QUICK START FUNCTION—OPTIONAL

When enabled, the quick-start feature will become available in the event the capacitive buffer is no longer able to maintain power to the iCOM controller and iCOM powers down. Upon power restoration to the iCOM controller, the quick-start feature shall activate and provide fan/cooling output. The quick-start feature shall support the full range of cooling operating modes for the DSE system: DX Mode, Mixed Mode, and Pump Mode (EconoPhase). Upon a system power restoration, the DSE unit will continue operation and start in the last known cooling operating mode that was active prior to the loss of power. Unit restart time for full cooling shall be 40 seconds or less after power to the unit has been restored, with fans starting within 15 seconds. The unit shall be equipped with a UPS or capacitive buffer to provide the Liebert iCOM with a minimum of 3 minutes of ride-through power. The capacitive buffer shall provide power for continuous connectivity to the Building Management System(s) via Liebert iCOM control.

6.2 WIRED REMOTE SENSOR(S)—OPTIONAL

Each Liebert iCOM™ can have up to ten (10) 2T sensors (20 sensor readings total) for control or reference. As part of the U2U network, those sensors shall be shared and used to control the cooling units and provide greater flexibility, visibility and control to respond to changes in the conditioned space. When the sensors are used for control, the user may set the control to be based off a maximum or average of a selected highest temperature reading.

6.3 STATIC PRESSURE TRANSDUCER(S)—OPTIONAL

Each Liebert iCOM shall have up to four factory-installed and factory-programmed static pressure transducer(s). The transducer(s) may be used for control of fan speed or reference of the supply plenum pressure. When used for control, the Liebert iCOM shall be capable of:

- Sharing sensor data across multiple units in the U2U network to provide greater flexibility, visibility and control. Only one transducer shall be required for a group of units, however, multiple transducers may be applied per group and aggregated for redundancy.
- Offering the user selections to control fan off either the average or lowest pressure reading collected in the U2U network.

6.4 AIRFLOW MONITORING—OPTIONAL

Liebert iCOM shall monitor evaporator fan airflow for monitoring purpose.

6.5 POWER MONITORING—OPTIONAL

The unit shall be equipped with factory-programmed/installed power meters to monitor power characteristics for either individual component or total unit. These meters allow the user to monitor meter connection status, input under voltage, input RMS voltage leg-to-leg and leg-to ground, input current for each phase, energy consumption in kilowatt hours and instantaneous power in watts. In multi-unit applications, a phase loss protection routine shall place a unit into standby mode in the event that phase loss is detected.

6.6 DUAL LOCKING DISCONNECT WITH AUTOMATIC TRANSFER CONTROLLER—OPTIONAL

Dual locking disconnects with an ATS controller shall be provided to automatically switch between the main and auxiliary power source when the main source has lost power.

6.7 120-V UTILITY POWER FROM MAIN-UNIT POWER SUPPLY—OPTIONAL

Factory installed enclosure with stepdown transformer shall provide 120V power for utility light and outlet from customer supplied three phase power supply.

6.8 LIEBERT VNSA™ NETWORK SWITCH-OPTIONAL

The Liebert vNSA network switch is designed for networking multiple iCOM unit-level controllers together. There shall be two different styles of the vNSA14 panel available:

- vNSA14 – enclosure with network switches only
- vNSA14-iCOM-H – enclosure with network switches and 9" iCOM color touchscreen display

Each offering shall be housed inside a steel enclosure secured with a key lock and contain two network switches, providing a total of 14 Ethernet ports available for iCOM controller unit-to-unit networking. The Liebert vNSA requires field supplied, hard wiring, 16AWG, 100-240VAC universal (12V, 1.5A) single-phase input power supply for 120V or 230V operation with factory supplied power connector.

7.0 EXECUTION

7.1 INSTALLATION OF THERMAL MANAGEMENT UNITS

The customer or the customer's representative shall be responsible for the following:

7.1.1 GENERAL

Install Thermal Management units in accordance with the manufacturer's installation instructions. Install units plumb and level, firmly anchored in locations indicated and maintain the manufacturer's recommended clearances.

7.1.2 ELECTRICAL WIRING

Install and connect electrical devices furnished by the manufacturer but not specified to be factory mounted. Furnish copy of the manufacturer's electrical connection diagram submittal to electrical contractor.

7.1.3 DRAIN WATER PIPING

Connect drains to air-conditioning unit. Provide pitch and trap as manufacturer's instructions and local codes require.

7.2 FIELD QUALITY CONTROL

Start cooling units in accordance with the manufacturer's startup instructions. Test controls and demonstrate compliance with requirements. These specifications describe requirements for a computer room environmental control system. The system shall be designed to maintain temperature and humidity conditions in the rooms containing electronic equipment.

The manufacturer shall design and furnish all equipment to be fully compatible with heat dissipation requirements.

7.3 WARRANTY START-UP AND CONTROL PROGRAMMING

Engage manufacturer's field service technician to provide warranty start-up supervision and assist in programming of unit(s) controls and ancillary panels supplied by them.

This page intentionally left blank





Vertiv.com | Vertiv Headquarters, 1050 Dearborn Drive, Columbus, OH, 43085, USA

© 2019 Vertiv Group Corp. All rights reserved. Vertiv and the Vertiv logo are trademarks or registered trademarks of Vertiv Group Corp. All other names and logos referred to are trade names, trademarks or registered trademarks of their respective owners. While every precaution has been taken to ensure accuracy and completeness herein, Vertiv Group Corp. assumes no responsibility, and disclaims all liability, for damages resulting from use of this information or for any errors or omissions. Specifications are subject to change without notice.

SL-18956_REV2/590-2147-501B