



Liebert[®] MC

Installer/User Guide

60 Hz, Air Cooled Microchannel Condenser, Premium/EC Fan

The information contained in this document is subject to change without notice and may not be suitable for all applications. While every precaution has been taken to ensure the accuracy and completeness of this document, Vertiv assumes no responsibility and disclaims all liability for damages resulting from use of this information or for any errors or omissions.

Refer to local regulations and building codes relating to the application, installation, and operation of this product. The consulting engineer, installer, and/or end user is responsible for compliance with all applicable laws and regulations relation to the application, installation, and operation of this product.

The products covered by this instruction manual are manufactured and/or sold by Vertiv. This document is the property of Vertiv and contains confidential and proprietary information owned by Vertiv. Any copying, use, or disclosure of it without the written permission of Vertiv is strictly prohibited.

Names of companies and products are trademarks or registered trademarks of the respective companies. Any questions regarding usage of trademark names should be directed to the original manufacturer.

Technical Support Site

If you encounter any installation or operational issues with your product, check the pertinent section of this manual to see if the issue can be resolved by following outlined procedures.

Visit <https://www.vertiv.com/en-us/support/> for additional assistance.

TABLE OF CONTENTS

1 Important Safety Instructions	1
2 Nomenclature and Components	5
2.1 Vertiv™ Liebert® MC Model Number Nomenclature	5
2.2 Product Description and Features	7
2.2.1 Control, Fan Types, and Features	7
2.2.2 Premium Control EC Fan	7
2.2.3 Features Available for Vertiv™ Liebert® DX Only Systems	8
2.2.4 Vertiv™ Liebert® Quiet-Line Low Noise Feature	8
2.2.5 Features Available for Vertiv™ Liebert® EconoPhase or EEV Systems	9
3 Pre-installation Preparation and Guidelines	11
3.1 Planning Dimensions	11
3.2 Shipping Dimensions and Weights	12
3.2.1 Condenser and Options Net Weights	13
4 Equipment Inspection and Handling	17
4.1 Packaging Material	17
4.2 Unit Storage	17
4.3 Handling Unit on the Skid	18
4.3.1 Using a Forklift	18
4.3.2 Using a Crane	18
4.4 Unpacking the Unit—All Unit Sizes	19
4.5 Preparing a Condenser for Moving and Installation	19
4.5.1 Attaching 18-in. (457 mm) Legs, Removing the Skid, and Attaching Slings	19
4.5.2 Attaching 36-in. to 60-in. (914 mm to 1524 mm) Legs, Removing the Skid, and Attaching Slings	22
4.6 Mounting the Condenser	25
4.6.1 Standard Mounting Requirements	25
4.6.2 Seismic Certified and Wind Certified Mounting Requirements	25
5 Piping	27
5.1 Refrigerant Piping and Charging	28
5.1.1 Refrigerant Piping Guidelines for Air Cooled Systems	28
5.1.2 Recommended Refrigerant Line Sizes	30
5.1.3 Refrigerant Charge Requirements	31
5.1.4 System Refrigerant Pressures	33
5.1.5 Additional Oil Requirements	33
5.2 Equipment Application Guidelines	33
5.3 System Dehydration/Leak Test	33
5.4 Charging for Condensers with Vertiv™ Liebert® Lee-Temp Receivers	33
5.5 Charging for Condensers with Vertiv™ Liebert® PDX-EEV Receivers	34

- 5.6 Charging for Condensers with Vertiv™ Liebert® DSE Receivers34
- 5.7 Charging for Condensers without Receivers 34
- 6 Electrical Connections 35**
- 6.1 Line Voltage Wiring 37
- 6.2 Electrical Power Requirements 37
- 6.3 Wye vs. Delta Connected Power Supply 40
- 6.4 Low Voltage Control Wiring—CANbus Communication 40
- 7 Checklist for Completed Installation 41**
- 7.1 Moving and Placing Equipment 41
- 7.2 Electrical Installation Checks 41
- 7.3 Piping Installation Checks 41
- 7.4 Other Installation Checks 41
- 8 Initial Startup Checks and Commissioning Procedure for Warranty Inspection 43**
- 9 Troubleshooting 45**
- 10 Control Operation 47**
- 10.1 Premium Efficiency Control Board and Interface 47
 - 10.1.1 Initial Display upon Power On 49
 - 10.1.2 Navigating the Controller Interface Main Menu 49
 - 10.1.3 Analog Signals Menu 50
 - 10.1.4 Active Alarms Menu 52
 - 10.1.5 History Alarms Menu 53
- 11 Maintenance 57**
- 11.1 General Maintenance 58
- 11.2 Condenser Cleaning - Standard Coil 58
 - 11.2.1 When to Clean the Condenser Coil 58
 - 11.2.2 What to Use to Clean the Condenser Coil 58
 - 11.2.3 Cleaning the Condenser Coil 59
- 11.3 Condenser Cleaning - E-coat Coil 59
 - 11.3.1 General Instructions: (detailed instructions to follow) 59
 - 11.3.2 Detailed Instructions 61
- 11.4 Replacing the Condenser Fan 63
 - 11.4.1 Fan Replacement 64
 - 11.4.2 P--Menu Programming 65
 - 11.4.3 Manual Fan Addressing (No P-- Menu) 65
 - 11.4.4 Verifying the Fan Address 67
- 11.5 Replacing the Premium Efficiency Control Board 69
 - 11.5.1 Preparing to Replace the Board 69
 - 11.5.2 Installing the Replacement Board 71
- 12 Preventive Maintenance Checklist 73**

Appendices75
Appendix A: Technical Support and Contacts 75
Appendix B: Sound Data Tables 77
Appendix C: Optional Configuration for Vertiv™ Liebert® MC Seismic Application or Wind Load Certification89
Appendix D: Submittal Drawings 91

This page intentionally left blank

1 Important Safety Instructions

SAVE THESE INSTRUCTIONS

This manual contains important safety instructions that should be followed during the installation and maintenance of the Vertiv™ Liebert® MC. Read this manual thoroughly before attempting to install or operate this unit.

Only qualified personnel should move, install or service this equipment.

Adhere to all warnings, cautions, notices and installation, operating and safety instructions on the unit and in this manual. Follow all installation, operation and maintenance instructions and all applicable national and local building, electrical and plumbing codes.



WARNING! Arc flash and electric shock hazard. Open all local and remote electric power supply disconnect switches, verify with a voltmeter that power is Off and wear appropriate, OSHA approved personal protective equipment (PPE) per NFPA 70E before working within the electric control enclosure. Failure to comply can cause serious injury or death. Customer must provide earth ground to unit, per NEC, CEC and local codes, as applicable. Before proceeding with installation, read all instructions, verify that all the parts are included and check the nameplate to be sure the voltage matches available utility power. The Vertiv™ Liebert® iCOM™ controller does not isolate power from the unit, even in the “Unit Off” mode. Some internal components require and receive power even during the “Unit Off” mode of the Liebert® iCOM™ controller. The factory supplied disconnect switch is inside the unit. The line side of this switch contains live high voltage. The only way to ensure that there is NO voltage inside the unit is to install and open a remote disconnect switch. Refer to unit electrical schematic. Follow all local codes.



WARNING! Risk of electric shock. Can cause equipment damage, injury or death. Open all local and remote electric power supply disconnect switches and verify with a voltmeter that power is off before working within any electric connection enclosures. Service and maintenance work must be performed only by properly trained and qualified personnel and in accordance with applicable regulations and manufacturers’ specifications. Opening or removing the covers to any equipment may expose personnel to lethal voltages within the unit even when it is apparently not operating and the input wiring is disconnected from the electrical source.



WARNING! Risk of electric shock. Can cause serious injury or death. The Liebert® iCOM™ microprocessor does not isolate power from the unit, even in the "Unit Off" mode. Some internal components require and receive power even during the "unit off" mode of the Liebert® iCOM™ control. Open all local and remote electric power disconnect switches and verify with a voltmeter that power is Off before working on any component of the system.



WARNING! Risk of electric shock. Can cause serious injury or death. Open all local and remote electric power supply disconnect switches and verify with a voltmeter that power is off before working within the fan motor electric connection enclosures. Fan motor controls can maintain an electric charge for 10 minutes after power is disconnected. Wait 10 minutes after power is verified as off before working within the fan electric control/connection enclosures. Use only fully trained and qualified HVAC technicians to perform maintenance on the fans.



WARNING! Risk of over pressurization of the refrigeration system. Can cause explosive discharge of high pressure refrigerant, loss of refrigerant, environmental pollution, equipment damage, injury, or death. This unit contains fluids and gases under high pressure. Use extreme caution when charging the refrigerant system. Do not pressurize the system higher than the design pressure marked on the unit's nameplate.



WARNING! Risk of contact with high speed rotating fan blades. Can cause serious injury or death. Open all local and remote electric power supply disconnect switches, verify with a voltmeter that power is off, and verify that all fan blades have stopped rotating before working in the unit cabinet or on the fan assembly. If control voltage is applied, the fan motor can restart without warning after a power failure. Do not operate the unit with any or all cabinet panels removed.



WARNING! Risk of improper wiring, piping, moving, lifting and handling. Can cause equipment damage, serious injury or death. Installation and service of this equipment should be done only by qualified personnel who have been specially trained in the installation of air conditioning equipment and who are wearing appropriate, OSHA approved PPE.



WARNING! Risk of improper moving, lifting, or handling of the unit. Can cause equipment damage, injury or death. Read all of the following instructions and verify that all lifting and moving equipment is rated for the weight of the unit before attempting to move, lift, remove packaging from or prepare the unit for installation. See **Table 3.2** on page 12, for weights.



WARNING! Risk of improper wire sizing/rating and loose electrical connections. Can cause overheated wire and electrical connection terminals resulting in smoke, fire, equipment and building damage, injury or death. Use correctly sized copper wire only and verify that all electrical connections are tight before turning power On. Check all electrical connections periodically and tighten as necessary.



WARNING! Risk of electrical fire and short circuit. Can cause property damage, injury or death. Select and install the line side electrical supply wire and overcurrent protection device(s) according to the specifications on the unit nameplate(s), per the instructions in this manual and according to the applicable national, state and local code requirements. Use copper conductors only. Verify that all electrical connections are tight. Unit specific wiring diagrams are provided on each unit.



CAUTION: Risk of improper moving, lifting and handling. Can cause equipment damage or injury. Only properly trained and qualified personnel should work on this equipment. Condenser fan modules for MCL models weigh in excess of 92 lb (40.8 kg) each and fan modules for MCS and MCM models weigh in excess of 40 lb (18.1 kg) each. Use proper lifting techniques and wear appropriate, OSHA approved PPE to avoid injury and dropping the fan module during removal. Equipment used in handling/lifting, and/or installing the fan assembly must meet OSHA requirements. Use handling/lifting equipment rated for the weight of the fan assembly. Use ladders rated for the weight of the fan assembly and technicians if used during installation. Refer to handling/lifting, and/or installation equipment operating manual for manufacturer's safety requirements and operating procedures.



CAUTION: Risk of contact with sharp edges, splinters, and exposed fasteners. Can cause injury. Only properly trained and qualified personnel wearing appropriate, OSHA approved PPE should attempt to move, lift, remove packaging from or prepare the unit for installation.



CAUTION: Risk of contact with hot surfaces. Can cause injury. The electronic housing, refrigerant discharge lines, fan motor, and some electrical components are extremely hot during unit operation. Allow sufficient time for them to cool to a touch-safe temperature before working within the unit cabinet. Use extreme caution and wear appropriate, OSHA approved PPE when working on or near hot components.



CAUTION: Risk of exposure to harmful noise levels. Can cause hearing injury or loss. Depending on the installation and operating conditions, a sound pressure level greater than 70 dB(A) may arise. Take appropriate technical safety measures. Operating personnel must wear appropriate, OSHA approved PPE and observe all appropriate hearing protection safety requirements.

NOTICE

Risk of improper power supply connection. Can cause equipment damage and loss of warranty coverage.

Prior to connecting any equipment to a main or alternate power source (for example: backup generator systems) for startup, commissioning, testing, or normal operation, ensure that these sources are correctly adjusted to the nameplate voltage and frequency of all equipment to be connected. In general, power source voltages should be stabilized and regulated to within $\pm 10\%$ of the load nameplate nominal voltage. Also, ensure that no three phase sources are single phased at any time.

NOTICE

Risk of oil contamination with water. Can cause equipment damage.

Polyolester oil (POE oil), required with R-407C/R-410A and used with some R-22 systems, is much more hygroscopic than mineral oils. This means that POE oil absorbs water at a much faster rate when exposed to air than previously used mineral oils. Because water is the enemy of a reliable refrigeration system, extreme care must be used when opening systems during installation or service. If water is absorbed into the POE oil, it will not be easily removed and will not be removed through the normal evacuation process. If the oil is too wet, it may require an oil change. POE oils also have a property that makes them act as a solvent in a refrigeration system. Maintaining system cleanliness is extremely important because the oil will tend to bring any foreign matter back to the compressor or plug the microchannel coil. Always use a flow of dry nitrogen when brazing.

NOTICE

Risk of control malfunction. Can cause improper unit operation.

Verify that all low voltage electrical wiring has been performed per the schematic diagram provided and that all low voltage wiring connections are tight.

NOTICE

Condenser fans should be operated manually if they have not run for an extended time in an outdoor environment. Before enabling the condenser for normal cooling operation fans should be run at full speed for at least three hours once a month to move the bearings and allow any condensate that may have ingressed to evaporate.

Condenser firmware release 1.06.045 & later include settings to operate condenser fans if they have been inactive for more than 30 days.

2 Nomenclature and Components

This section describes the model number for Vertiv™ Liebert® MC units and components.

2.1 Vertiv™ Liebert® MC Model Number Nomenclature

Table 2.2 below describes each digit of the 25 digit configuration number. The 14 digit model number consists of the first 10 digits and last four digits of the configuration number.

Table 2.1 Liebert® MC 25 Digit Configuration Number Example

Model # Part 1										Model Details											Model # Part 2			
1	2	3	4	5	6	7	8	9	10	11	12	13	14	15	16	17	18	19	20	21	22	23	24	25
M	C	M	0	4	0	E	1	A	D	0	A	0	V	U	0	0	0	0	0	0	*	*	*	*

Table 2.2 MC Model Number Digit Definitions

Digit	Description
Digits 1 and 2 = Unit Family	MC = Microchannel Condenser
Digit 3 Platform Size	S = Small M = Medium L = Large
Digits 4-6 - Nominal Capacity, kW	028, 040, 055, 056, 080, 110, 160, 165, 220 Example: 040 = 40kW @ 95°F(35°C) & 27°R (15°K) ITD
Digit 7 - Control/Fan Type	E = Premium control and EC fan
Digit 8 - Refrigerant Circuits/System Refrigerant Type	1 = Single refrigerant circuit, R-410A 2 = Dual refrigerant circuit, R-410A 7 = Single refrigerant circuit, R-407C, R-22 8 = Dual refrigerant circuit, R-407C, R-22
Digit 9 - Power Supply	A = 460V/3ph/60Hz B = 575V/3ph/60Hz Y = 208/230V/3ph/60Hz 2 = 380V/3ph/60Hz

Table 2.2 MC Model Number Digit Definitions (continued)

Digit	Description
Digit 10 - Packaging	D = Domestic, non-stackable E = Export crating, non-stackable
Digit 11 - Coil Coating	0 = None E = E-coat (epoxy) with UV top coat
Digit 12 - Panel Material	A = Bright aluminum
Digit 13 - Connection Pipe Unit of Measurement	0 = Inches (std. ACR copper)
Digit 14 - Legs Included	V = 18-in. tall legs (standard) X = 36-in. tall legs with bracing Y = 48-in. tall legs with bracing Z = 60-in. tall legs with bracing
Digit 15 - Agency Certification	U = CSA listed, marked with CSA c-us logo 1 = IBC/OSHPD Seismic Certification, IBC/FBC Wind Load Certification and IBC Snow Load Certification
Digit 16 - Undefined, Reserved for future use.	
Digit 17 - Receiver/Leg/Software Configuration	0 = No Receiver Leg/Software 1 = Vertiv™ Liebert® Lee-Temp Receiver Leg/Software 2 = Vertiv™ Liebert® DSE and Vertiv™ Liebert® PDX unheated Receiver Leg/Software
Digits 18-21 - Undefined, Reserved for future use.	
Digits 22-25 - Factory Configuration Number	

2.2 Product Description and Features

The Vertiv™ Liebert® MC condenser is a low profile, direct drive propeller fan type, air cooled heat rejection unit suitable for mounting outdoors. It provides heat rejection for one or two separate refrigeration circuits, matches the heat rejection capacity corresponding with the outdoor ambient temperature and with each corresponding compressor heat rejection requirements. Constructed with an aluminum cabinet, a galvanized steel frame, and aluminum micro-channel coil, the unit is quiet and corrosion resistant. The condenser is quickly and easily installed, because all internal wiring is completed at the factory with only electrical connections to be made at the job site. All electrical connections and controls are enclosed in an integral, weatherproof section of the condenser.

Figure 2.1 Two Fan Liebert® MC



2.2.1 Control, Fan Types, and Features

2.2.2 Premium Control EC Fan

Premium Efficiency Controls and EC fans are matched to provide superior system energy efficiency. The premium control board allows CANbus communication with the indoor unit's Vertiv™ Liebert® iCOM™ control. This communication feature provides compressor run signals, condenser operating mode changes, condenser alarm monitoring, simplified system charging procedures and outdoor temperature monitoring.

The Premium Efficiency Control board on a Vertiv™ Liebert® MC with a dual refrigeration circuit adjusts the speed of fans on each circuit to match each circuit's head pressure conditions. On a condenser with multiple fans and a single refrigeration circuit, the premium control adjusts the fans to the same speed to maintain head pressure. The control system provides refrigerant head pressure control for outdoor ambient temperatures as low as -30°F (-35°C), provided that the total design range (from minimum to maximum) is 125°F (70°C) or less. For traditional Vertiv™ Liebert® DX applications, Vertiv™ Liebert® Lee-Temp kits are required only when the design temperature ranges exceed 125°F (70°C) for standard sound matchups. Liebert® Lee-Temp kits are always required for Vertiv™ Liebert® Quiet-Line (low noise) match-ups.

Anti-Freezing Operation

The EC fans must be operated periodically in cold weather to reduce the possibility of lock-up due to ice and snow accumulation. During periods of fan inactivity and outdoor temperatures below 35°F (1.6°C), the EC fans will spin for at least 30 seconds every 15 minutes at 60% of the maximum fan speed.

Fan Reversal for Cleaning

The Vertiv™ Liebert® iCOM™ can run the Premium EC fans in reverse to clear loose debris from the coil between scheduled coil cleanings. You can reverse the fans manually or automatically with a programmed schedule. The automatic fan reversal interval occurs when the indoor unit is Off (BMS Off, U2U Network Standby or Remote Shut Down [RSD]).

Surge Protective Device

An optional surge protective device (SPD) can be field wired to protect the condenser from power surges that threaten sensitive equipment. The condenser's electrical panel provides a terminal block to allow the SPD to be wired in parallel with the high voltage power. An additional low voltage terminal block is provided on condensers to allow monitoring of the SPD alarm circuit.

ASCO Series 420 surge protective device provides 50 kA per mode of surge current protection. An illuminated green LED indicates the SPD is On and operating properly. An illuminated red LED indicates that the device may require replacement.

When both LEDs are Off, there is no power to the condenser, either from a power failure or because the condenser disconnect is in the Off position.

2.2.3 Features Available for Vertiv™ Liebert® DX Only Systems

2.2.4 Vertiv™ Liebert® Quiet-Line Low Noise Feature

The Liebert® Quiet-Line low noise feature limits the condenser fan speed to reduce operating noise at certain times. Special matchups of condensers are available for applications to meet stringent sound regulations. Lower sound levels are achieved by oversizing the condenser, which decreases the maximum air flow of each fan and thus sound level produced by the condenser. This feature requires special set up of the indoor unit. A Vertiv™ Liebert® Lee-Temp receiver is required for each refrigerant circuit. The premium control has gain schedules that override the customer defined low noise schedule to prevent indoor unit high pressure alarm conditions from occurring should higher than design temperatures occur. This feature only functions with Vertiv™ Liebert® DX systems, and the feature is controlled using Vertiv™ Liebert® iCOM™ low noise mode.

Vertiv™ Liebert® Lee-Temp Refrigerant Control

The Liebert® Lee-Temp head pressure control system uses head pressure control valve(s), extra refrigerant, and insulated refrigerant receiver(s) with heater pads to assist system starting. The Liebert® Lee-Temp control system also maintains proper operating head pressures when outdoor temperatures fall below the temperature approved for system match up without Liebert® Lee-Temp receivers. The system floods the condenser coil with liquid refrigerant to a level that balances the system condensing requirements with the condenser coil surface available to reject the system heat. During the summer, the system requires the entire condenser coil surface for heat rejection and most of the refrigerant is stored in the receiver. In the winter, the same amount of heat can be rejected by only a fraction of the coil surface. As head pressure begins to fall, the control valve restricts the flow of liquid refrigerant from the condenser. This extra liquid refrigerant reduces the effective condenser surface area available for heat transfer. The head pressure control valve also bypasses hot gas into the receiver to warm the liquid and maintain liquid pressure for proper operation of the expansion valve. The Liebert® Lee-Temp kit is optional for condensers and is field installed. Condenser control boards are factory configured for Liebert® Lee-Temp if they are ordered with Lee-Temp receivers and can be field configured if a Lee-Temp system is added later.

2.2.5 Features Available for Vertiv™ Liebert® EconoPhase or EEV Systems

Vertiv™ Liebert® DSE and Vertiv™ Liebert® PDX-EEV Unheated Receiver

Liebert® DSE and Liebert® PDX with EEV systems require unheated receivers to manage refrigerant volume fluctuations in the evaporator coil, which occur during normal operation. The receivers are field mounted on the Vertiv™ Liebert® MC condenser and are field piped in the liquid line between the condenser and the indoor unit. The receiver discharge must be mounted higher than the EEV height of the indoor unit.

This page intentionally left blank

3 Pre-installation Preparation and Guidelines

The unit dimensions, pipe connection locations, and piping schematics are described in the submittal documents included in the [Submittal Drawings](#) on page 91.

- Install the condenser in a location offering maximum security and access for maintenance.
- Avoid ground level sites with public access and areas prone to heavy snow or ice accumulations.
- To ensure adequate air supply, we recommend that condensers be installed in an area with clean air, away from loose dirt and foreign matter that might clog the coil. In addition, condensers should be located no closer than 3 ft. (1 m) from a wall, obstruction, or adjacent unit.
- For roof installation, mount the condenser on suitable curbs or other supports in accordance with local codes.
- Locations that require additional coil corrosion protection, such as coastal regions, heavy industrial, or agricultural air pollution, should specify coils with the optional epoxy E-coat.
- Condensers must not be installed in a pit.
- Condensers must be installed on a level surface to ensure proper refrigerant flow.
- Condensers must be installed in vertical airflow orientation to maintain the electrical box's NEMA 3R rating.

Condenser with Receiver

- Cannot be installed below the evaporator
- EEV units: The outlet of the receiver on the outdoor, Vertiv™ Liebert® MC condenser must be higher than the elevation of the electronic expansion valves (EEV) inside the indoor unit. The vertical height of the receiver outlet must not exceed 60 ft. (18.3 m) above the EEV.
- TXV units: The bottom of the receiver on the outdoor Liebert® MC condenser must be higher than the elevation of the thermal expansion valves (TXV) inside the indoor unit. The vertical height of the bottom of the receiver must not exceed 60 ft. (18.3 m) above the TXV.
- Consult factory before installing units, condensers, and receivers outside these parameters.
- Refer to DPN003954, DPN003993, and DPN003994 included in [Submittal Drawings](#) on page 91.
- Receiver tanks should be mounted on the condenser legs for proper operation. Contact Vertiv's Application Engineering Department for assistance with applications requiring remote mounting of receivers.

Condenser without Receiver

- The bottom of the condenser coil must be less than 15 ft. below the location of the TXV inside the indoor unit.
- The vertical height of the bottom of the condenser coil must not exceed 60 ft. (18.3 m) above the TXV inside the indoor unit.
- Consult factory before installing units and condensers outside these parameters.
- Refer to DPN003954 included in [Submittal Drawings](#) on page 91.

3.1 Planning Dimensions

The condenser dimensions are described in the submittal documents included in the [Submittal Drawings](#) on page 91. Condensers mounted above and below the relative elevation of the indoor unit must follow the guidelines found in the submittal drawings listed in the table.

The following table lists the relevant documents by number and title.

Table 3.1 Dimension Planning Drawings

Document Number	Title
DPN003436	Cabinet and Anchor Dimensional Data 1 Fan (MCS028, MCM040, MCL055)
DPN003437	Cabinet and Anchor Dimension Data 2 Fan (MCS056, MCM080, MCL110) Dual Circuit
DPN003756	Condenser and Anchor Dimensional Data (MCM080, MCL110) Single Circuit
DPN003438	Condenser Dimensional Data, MCL165
DPN003439	Condenser Dimensional Data 4 Fan (MCM160 and MCL220)
Receiver Mounting	
DPN003839	Liebert® PDX-EEV Receiver Mounting MCS028, MCM040, and MCM080 Single Circuit Condenser Left Side Option
DPN003455	Liebert® DSE Receiver Mounting MCM Single Circuit Left Side Condenser Outlet Receiver
DPN002554	Left Side Liebert® DSE and Liebert® PDX-EEV Receiving Mounting Kit MCL055, MCL110, MCL165, MCL220 Single Circuit Compressor
DPN002383	Liebert® DSE Receiver Mounting MCM160 Circuit Dual Condenser Outlet Receivers
Condenser Elevation Above/Below Indoor Unit	
DPN003954	Air Cooled Piping Schematic Condenser above Indoor Unit
DPN003993	Air Cooled Piping Schematic Liebert® MC with Receiver above Unit
DPN003994	Air Cooled Piping Schematic Liebert® MC Mounted above Liebert® DA080-165

3.2 Shipping Dimensions and Weights

Table 3.2 Condenser Shipping Weights, Dimensions and Volume, Approximate

Model Number	Number of Fans	Domestic Packaging			Export Packaging		
		Weight, lb (kg)	Dimensions L x W x H, in. (cm)	Volume, ft ³ (m ³)	Weight, lb (kg)	Dimensions L x W x H, in. (cm)	Volume, ft ³ (m ³)
MCS028	1	406 (184)	81 X 34 X 65 (206 X 86 X 165)	104 (2.9)	536 (243)	82 X 35 X 65 (208 X 88 X 165)	107 (3.0)
MCS056	2	651 (295)	137 X 34 X 65 (348 X 86 X 165)	175 (4.9)	849 (385)	138 X 35 X 65 (350 X 88 X 165)	181 (5.1)
MCM040	1	468 (212)	81 X 34 X 65 (206 X 86 X 165)	104 (2.9)	585 (265)	82 X 35 X 65 (208 X 88 X 165)	107 (3.0)
MCM080	2	822 (373)	137 X 34 X 65 (348 X 86 X 165)	175 (4.9)	1020 (462)	138 X 35 X 65 (350 X 88 X 65)	181 (5.1)
MCM160	4	1545 (701)	249 X 34 X 65 (632 X 86 X 165)	317 (9.0)	1879 (852)	250 X 35 X 65 (634 X 88 X 165)	327 (9.3)

Table 3.2 Condenser Shipping Weights, Dimensions and Volume, Approximate (continued)

Model Number	Number of Fans	Domestic Packaging			Export Packaging		
		Weight, lb (kg)	Dimensions L x W x H, in. (cm)	Volume, ft ³ (m ³)	Weight, lb (kg)	Dimensions L x W x H, in. (cm)	Volume, ft ³ (m ³)
MCL055	1	581 (263)	81 X 34 X 65 (206 X 86 X 165)	104 (2.9)	698 (316)	82 X 35 X 65 (208 X 88 X 165)	107 (3.0)
MCL110	2	983 (446)	137 x 34 x 65 (348 X 86 X 165)	175 (4.9)	1181 (535)	138 X 35 X 65 (350 X 88 X 165)	181 (5.1)
MCL165	3	1412 (640)	193 X 34 X 65 (490 X 86 X 165)	246 (7.0)	1678 (761)	194 X 35 x 65 (492 X 88 X 165)	254 (7.2)
MCL220	4	1840 (835)	249 X 34 X 65 (632 X 86 X 165)	317 (9.0)	2174 (986)	250 X 35 X 65 (634 X 88 X 165)	327 (9.3)

Packaged weights will increase with factory options, such as legs taller than 18" (457mm), coated coils, 575V and seismic/wind options. See **Table 3.3** below, **Table 3.4** on the next page and **Table 3.5** on page 15 for option weights to add to the packaged weights above. Consult factory for additional information.

Receivers and 60-in. legs are shipped separately from the condenser.

3.2.1 Condenser and Options Net Weights

Total unit weight is the sum of the condenser weight with the selected legs plus the weight of any option.

Table 3.3 Condenser and Option Net Weights—Small Condensers

Condenser Model		MCS028	MCS056
Refrigeration Circuits		1	2
Condenser Dry Weight, lb (kg)	18" Leg	183 (83)	299 (136)
	36" Leg	286 (130)	419 (190)
	48" Leg	318 (144)	451 (205)
	60" Leg	349 (158)	482 (219)
Additional Weight for Options, lb (kg)			
Liebert® PDX-EEV Receiver		45 (20)	—
Vertiv™ Liebert® Lee-Temp Receiver		55 (25)	124 (56)
575V Transformer		55 (25)	65 (29)
Coated Coil		4 (2)	8 (4)
Seismic/Wind Bracing, 18 in. legs		56 (25)	56 (25)
Condenser + Liebert® PDX-EEV Receiver or Liebert® Lee-Temp + Coated Coil + 575V Transformer + Seismic/Wind Bracing = Total Weight			
Source: DPN003034, Rev. 6			

Table 3.4 Condenser and Option Net Weights—Medium Condensers

Condenser Model		MCM040	MCM080	MCM080	MCM160
Refrigeration Circuits		1	1	2	2
Condenser Dry Weight, lb (kg)	18-in. Leg	260 (118)	470 (213)	470 (213)	903 (410)
	36-in. Leg	363 (165)	590 (268)	590 (268)	1066 (484)
	48-in. Leg	395 (179)	622 (282)	622 (282)	1114 (505)
	60-in. Leg	426 (193)	653 (296)	653 (296)	1160 (526)
Additional Weight for Options, lb (kg)					
Liebert® PDX EEV Receiver		45 (20)	52 (24)	—	—
Vertiv™ Liebert® Lee-Temp Receiver		55 (25)	107 (49)	124 (56)	234 (106)
Vertiv™ Liebert® DSE Receiver DA050/080/085		—	52 (24)	—	104 (47)
Liebert® DSE Receiver DA125/150/165		—	99 (45)	—	198 (90)
575V Transformer		60 (27)	70 (32)	70 (32)	80 (36)
Coated Coil		5 (2)	10 (5)	10 (5)	20 (9)
Seismic/Wind Bracing, 18-in. legs		56 (25)	56 (25)	56 (25)	80 (36)
Condenser + Liebert® PDX EEV Receiver or Liebert® Lee-Temp or Liebert® DSE Receiver + Coated Coil + 575V Transformer + Seismic/Wind Bracing = Total Weight					
Source: DPN003034, Rev. 6					

Table 3.5 Condenser and Option Net Weights—Large Condensers

Condenser Model		MCL055	MCL110	MCL110	MCL165	MCL220	MCL220
Refrigeration Circuits		1	1	2	1	1	2
Condenser Dry Weight, lb (kg)	18-in. Leg	373 (169)	631 (286)	631 (286)	934 (424)	1229 (557)	1229 (557)
	36-in. Leg	486 (220)	766 (347)	766 (347)	1136 (515)	1453 (659)	1453 (659)
	48-in. Leg	518 (235)	798 (362)	798 (362)	1184 (537)	1501 (681)	1501 (681)
	60-in. Leg	549 (249)	829 (376)	829 (376)	1230 (558)	1547 (702)	1547 (702)
Additional Weight for Options, lb (kg)							
Liebert® PDX EEV Receiver		45 (20)	—	—	—	—	—
Liebert® Lee-Temp Receiver		60 (27)	122 (55)	134 (61)	182 (83)	222 (101)	254 (115)
Liebert® DSE Receiver DA050/080/085		—	52 (24)	104 (47)	52 (24)	52 (24)	104 (47)
Liebert® DSE Receiver DA125/150/165		—	101 (46)	—	101 (46)	101 (46)	202 (92)
575V Transformer		67 (30)	77 (35)	77 (35)	118 (54)	118 (54)	118 (54)
Coated Coil		8 (4)	16 (7)	16 (7)	24 (11)	32 (15)	32 (15)
Seismic/Wind Bracing, 18-in. legs		56 (25)	56 (25)	56 (25)	80 (36)	80 (36)	80 (36)
Condenser + Liebert® PDX EEV Receiver or Liebert® Lee-Temp or Liebert® DSE Receiver + Coated Coil + 575V Transformer + Seismic/Wind Bracing = Total Weight							
Source: DPN003034, Rev. 6							

This page intentionally left blank

4 Equipment Inspection and Handling



WARNING! Risk of improper moving, lifting, or handling of the unit. Can cause equipment damage, injury or death. Read all of the following instructions and verify that all lifting and moving equipment is rated for the weight of the unit before attempting to move, lift, remove packaging from or prepare the unit for installation. See **Table 3.2** on page 12, for weights.



CAUTION: Risk of contact with sharp edges, splinters, and exposed fasteners. Can cause injury. Only properly trained and qualified personnel wearing appropriate, OSHA approved PPE should attempt to move, lift, remove packaging from or prepare the unit for installation.

NOTICE

Risk of improper lifting. Can cause equipment damage. Make sure that the spreader bars are wider than the unit. If the spreader bars are too short, the slings may crush the unit.

NOTICE

Risk of damage from forklift. Can cause unit damage. Keep tines of the forklift level and at a height suitable to fit below the skid and/or unit to prevent exterior and/or underside damage.

Upon arrival of the unit and before unpacking:

- Verify that the labeled equipment matches the bill of lading.
- Carefully inspect all items for visible or concealed damage.
- Report damage immediately to the carrier and file a damage claim with a copy sent to Vertiv or to your sales representative.
- If you have the seismic mounting kit, refer to [Optional Configuration for Vertiv™ Liebert® MC Seismic Application or Wind Load Certification](#) on page 89.

Equipment Recommended for Handling the Unit:

- Forklift
- Lift beam
- Slings
- Spreader bars
- Crane

4.1 Packaging Material



All material used to package this unit is recyclable. Please save for future use or dispose of the material appropriately.

4.2 Unit Storage

Store the condenser in the original packaging in an area protected from excessive dirt, debris and contact damage until final installation.

4.3 Handling Unit on the Skid

Transport unit using a fork lift or a crane with sling and spreader bars.

4.3.1 Using a Forklift

NOTICE

Risk of improper forklift handling. Can cause unit damage.

Keep the forklift tines level and at a height that will fit under the skid.

- Make sure the forks (if adjustable) are spread to the widest allowable distance to still fit under the skid.
- Type of forklift used will depend on the terrain the unit is to be moved across during handling.
- Minimum forklift fork length:
 - For 1 fan and 2 fan units—48 in. (1219 mm)
 - For 3 fan and 4 fan units—72 in. (1829 mm)
- When moving the packaged unit, do not lift it any higher than 6 in. (152 mm). If the unit must be lifted higher than 6 in. (152 mm), you must exercise great care, and no one may be closer than 20 ft. (6 m) to the lift point.
- We recommend lifting one end off the ground no more than 6 in. (152 mm) and using the forklift to push or pull the unit.

Figure 4.1 Forklift Position with 1 to 4 Fan Units

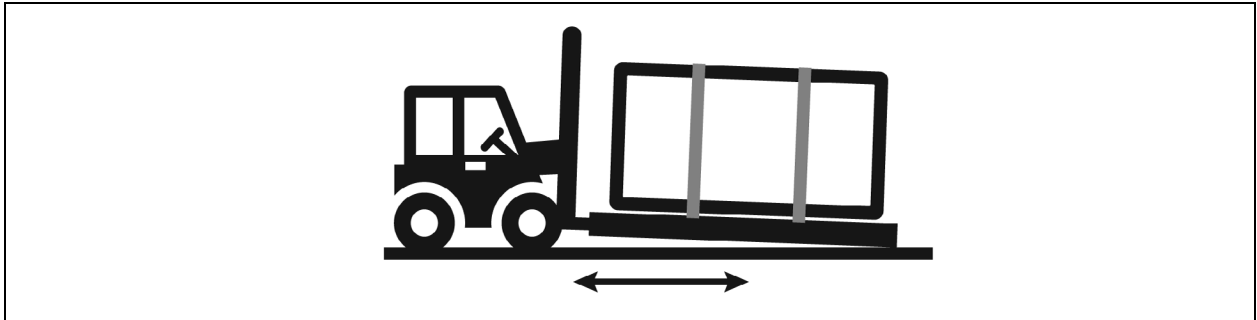

4.3.2 Using a Crane

- We recommend using slings rated for the unit weight.
- Spreader bars must be used for sling stability and to keep the slings from pressing against the unit. Make sure spreader bars are wider than the unit.
- Place the slings near the ends of the unit, under the top deck boards of the skid.

4.4 Unpacking the Unit—All Unit Sizes

Refer to **Figure 4.2** below for the steps:

Figure 4.2 Removing Protective Material

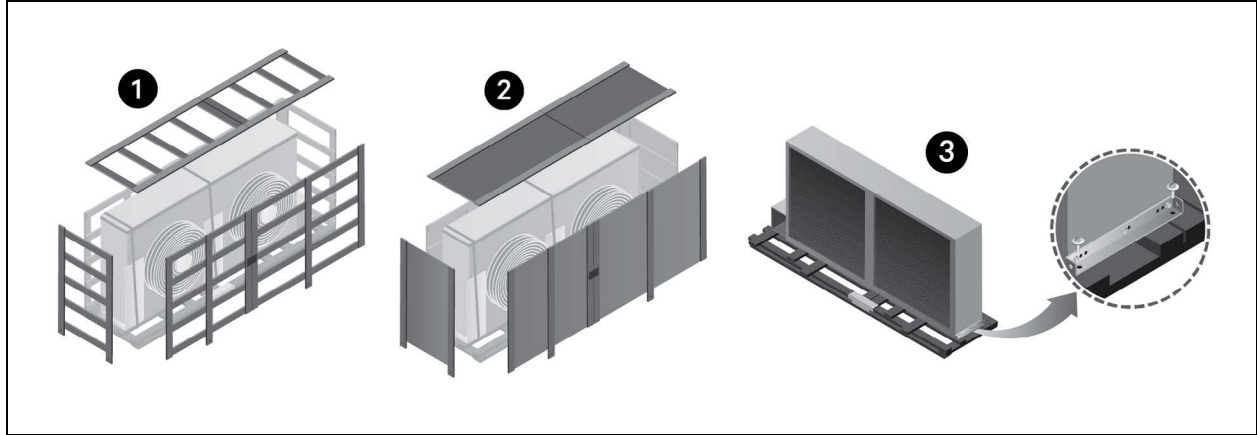

Item	Step
1	Remove the fence for domestic packaging, then remove the exterior foam from around the electric box. If legs are shipped with the unit, set the legs aside but keep them accessible
2	Remove the crate for export packaging, then remove the exterior foam from around electric box. If legs are shipped with the unit, set the legs aside but keep them accessible
3	Remove the bolts securing unit to the skid, then remove the bolts securing the brackets to the unit and recycle the brackets.

4.5 Preparing a Condenser for Moving and Installation

The following procedure is one method for removing a condenser from its shipping skid. Other methods may be used, provided that they are safe for personnel, the condenser and other equipment.

4.5.1 Attaching 18-in. (457 mm) Legs, Removing the Skid, and Attaching Slings

NOTE: For units supplied with 36-in. to 60-in. (914 mm to 1524 mm) legs, go to [Attaching 36-in. to 60-in. \(914 mm to 1524 mm\) Legs, Removing the Skid, and Attaching Slings](#) on page 22 .

- Attach legs to the unit at indicated locations, using the fasteners provided with the legs.
 - Recommended tools for attachment is a 13 mm socket and ratchet.
 - More legs may be available for installation than are shown. This depends on the unit type and number of fans.

Figure 4.3 Attaching Legs to Condensers

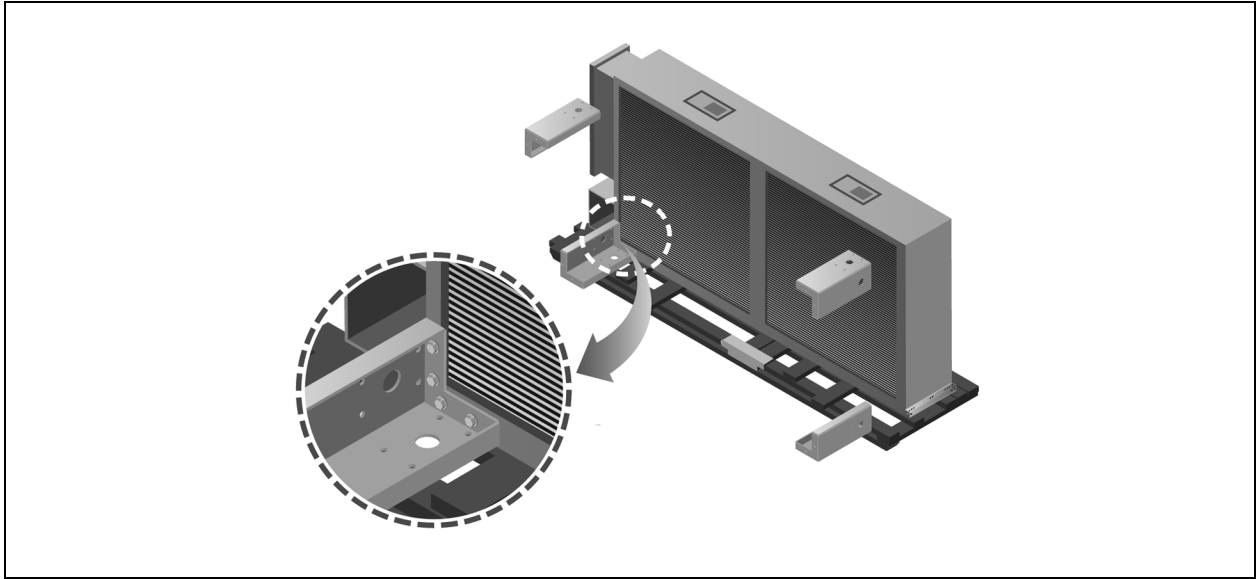

2. Place slings around the unit between the unit and the top deck boards of the skid as shown in **Figure 4.4** below :
 - **1 fan and 2 fan units:** against the inside of the attached legs.
 - **3 fan and 4 fan units:** against the outside of the attached eye bolts.
3. Use spreader bars, a lift beam and a crane to lift the unit off the skid. Make sure spreader bars are wider than the unit.

NOTICE

Risk of improper lifting. Can cause equipment damage. Make sure that the spreader bars are wider than the unit. If the spreader bars are too short, the slings may crush the unit.

Figure 4.4 Securing Slings to Condensers for Lifting off Skid

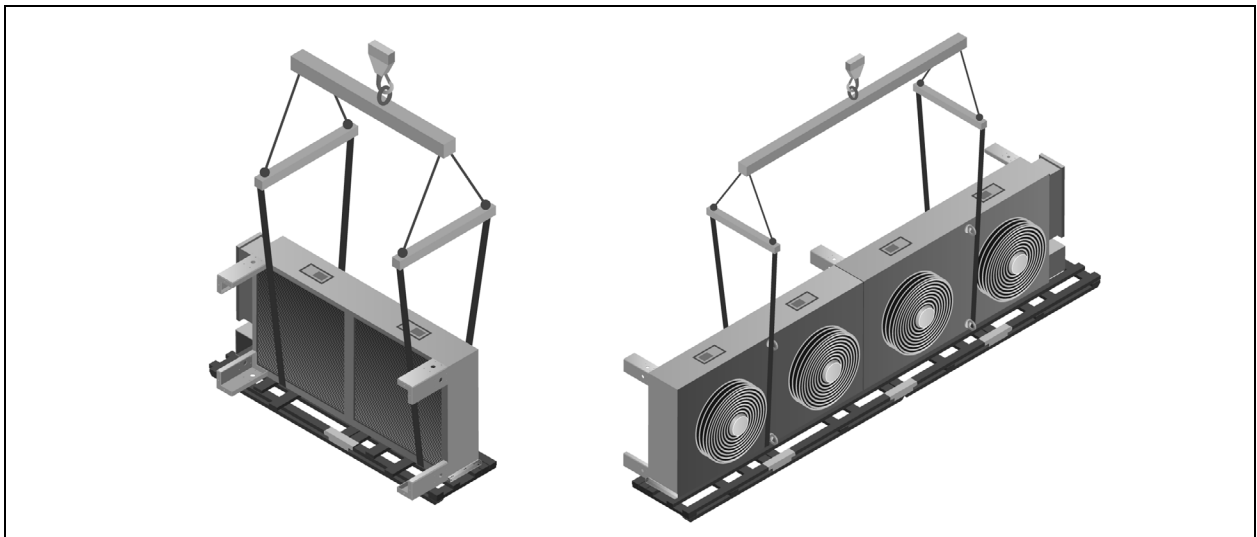

4. Lift the unit 24 in. (610 mm) off the top deck of the skid.
5. Remove the skid from under the unit.

6. To rotate the unit, a mechanized method is recommended, but if one is not available, use a minimum of four properly protected individuals to rotate the elevated unit 90 degrees so the unit legs are pointing toward the ground, **Figure 4.5** below .
7. Set the upright unit on the ground so the legs support unit weight.
8. Remove the straps from around unit.

Figure 4.5 Rotate and Set Condenser on Floor

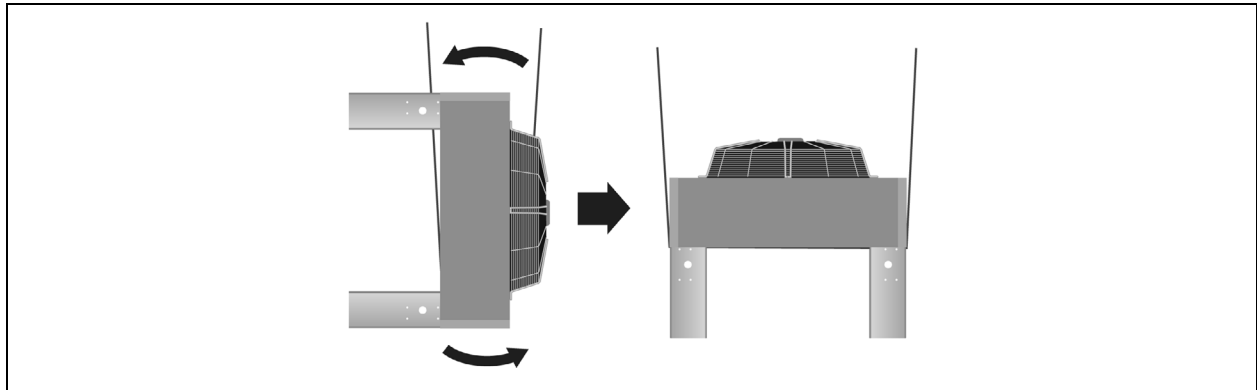

9. Refer to **Figure 4.6** on the next page to attach rigging for lifting. Spreader bars are still required. Make sure that the spreader bars are wider than the unit to prevent crushing force.
 - **1 fan and 2 fan units:** Route the straps through the large holes in the side of the legs.
 - **3 fan and 4 fan units:** Secure straps or chains to the eye bolts on top of the unit.

NOTICE

Risk of improper lifting. Can cause equipment damage. Make sure that the spreader bars are wider than the unit. If the spreader bars are too short, the slings may crush the unit.

The unit is ready to be lifted and moved to its installation location.

Figure 4.6 Rigging to Lift Condensers

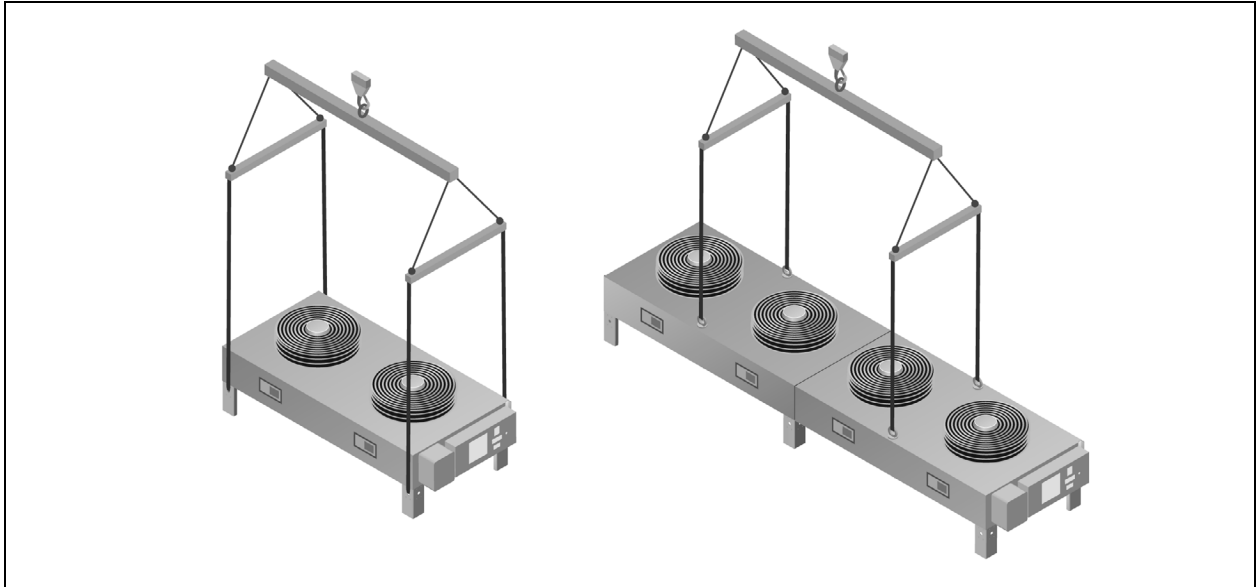

4.5.2 Attaching 36-in. to 60-in. (914 mm to 1524 mm) Legs, Removing the Skid, and Attaching Slings

1. Install bolts for sling containment guides during lifting/rotation:
 - Locate the recommended bolt locations shown in **Figure 4.7** on the facing page.
 - Insert 4 leg bolts, 2 on each end, leaving approximately 1/4 in. (6 mm) of the fastener threads exposed.
 - Do not insert bolt in the secondary bolt locations. These are used to attach the legs after the unit is moved into the installation location.
2. Assemble the leg structure according to the instructions supplied with the legs. Cross bracing for 4 legs is shown in **Figure 4.7** on the facing page.

NOTE: When assembling the leg structure, **DO NOT** tighten the cross-brace hardware until the condenser cabinet is fastened to the legs.

Figure 4.7 Recommended Bolt Locations for Lifting, Example of Cross Bracing for 4 Legs

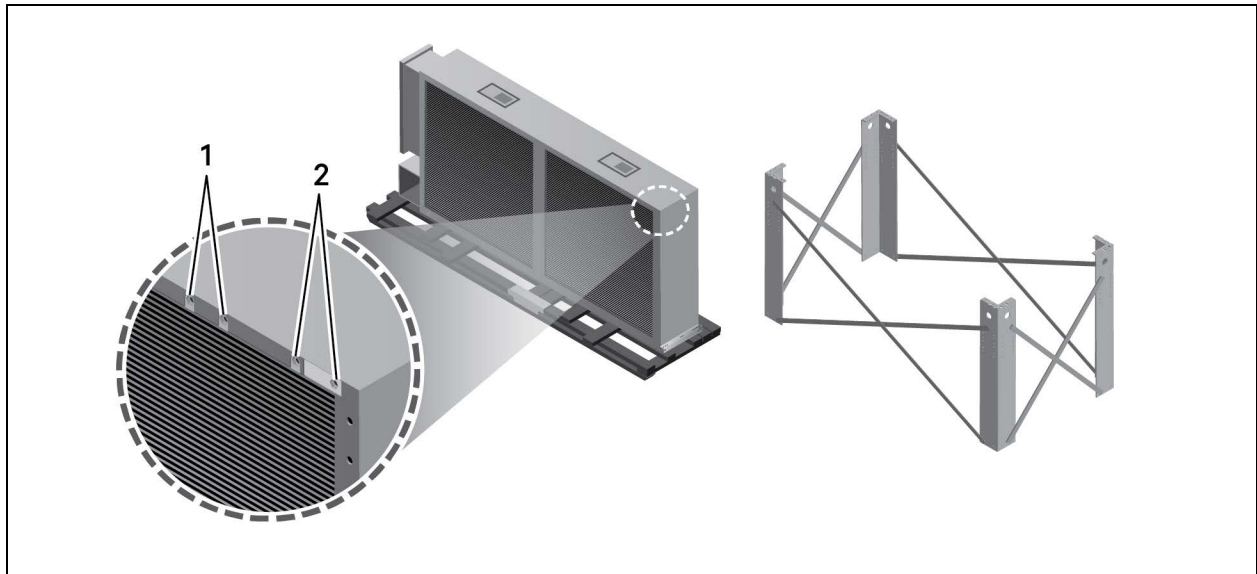

Item	Description
1	Recommended bolt location (four places)
2	Secondary bolt location (four places)

3. To attach rigging for lifting, attach slings between the unit and the top deck boards of the skid as follows: Spreader bars are required. Make sure that the spreader bars are wider than the unit to prevent crushing force.
 - **1 fan and 2 fan units:** Route the slings against the inside of the inserted leg bolts as shown in **Figure 4.8** on the next page .
 - **3 fan and 4 fan units:** Route the slings against the outside of the attached eye bolts.

NOTICE

Risk of improper lifting. Can cause equipment damage. Make sure that the spreader bars are wider than the unit. If the spreader bars are too short, the slings may crush the unit.

4. Use spreader bars, lift beam and crane to lift the unit 24-in. (610 mm) off the skid. Remove the skid from under the unit
5. To rotate the unit, a mechanized method is recommended, but if one is not available, use a minimum of four properly protected individuals to rotate the elevated unit 90 degrees so the unit fans are facing up, **Figure 4.8** on the next page .

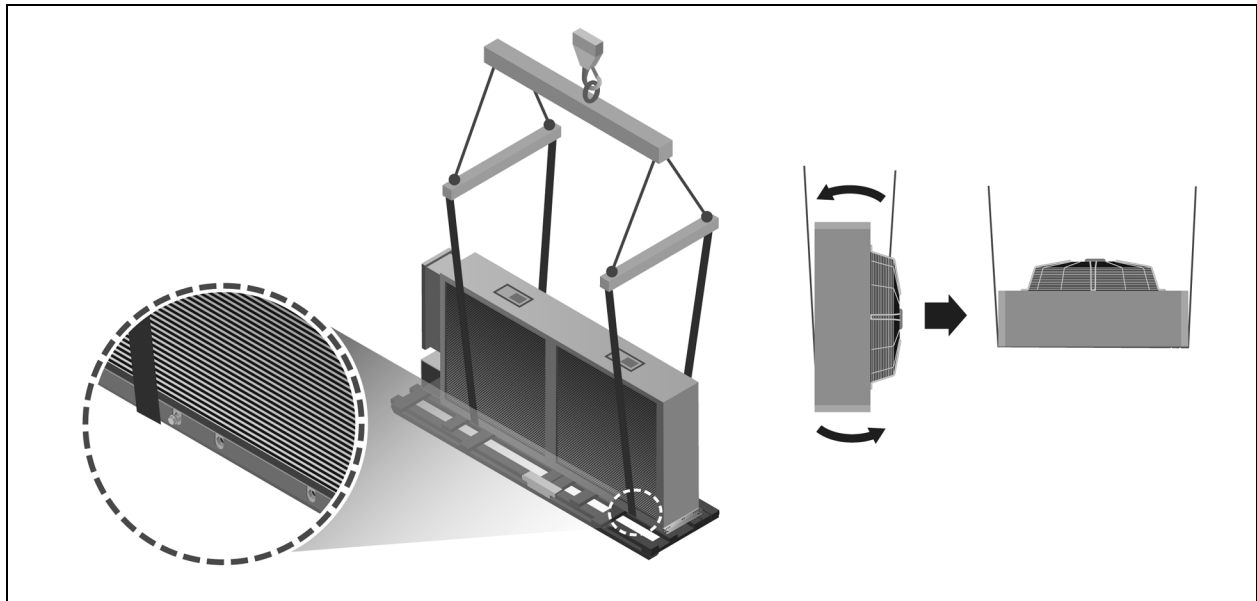
Figure 4.8 Sling Placements and Unit Rotation

6. Place the unit on the leg structure, resting the unit on the legs.
7. Remove the bolts inserted for strap containment. If the secondary locations were used, remove the bolts just before setting the unit on its legs.
8. Align, insert and tighten all hardware securing the unit to the leg structure.
9. Square up the leg structure and tighten all cross brace angle hardware.
10. Lower the unit so the leg structure supports the weight of the unit, and remove the straps from around the unit.
11. Refer to **Figure 4.9** on the facing page to attach rigging for lifting. Spreader bars are still required. Make sure that the spreader bars are wider than the unit to prevent crushing force.
 - **1 fan and 2 fan units:** Route the straps through the large holes in the side of the legs.
 - **3 fan and 4 fan units:** Secure straps or chains to the eye bolts on top of the unit.

NOTICE

Risk of improper lifting. Can cause equipment damage. Make sure that the spreader bars are wider than the unit. If the spreader bars are too short, the slings may crush the unit.

The unit is ready to be lifted and moved to its installation location.

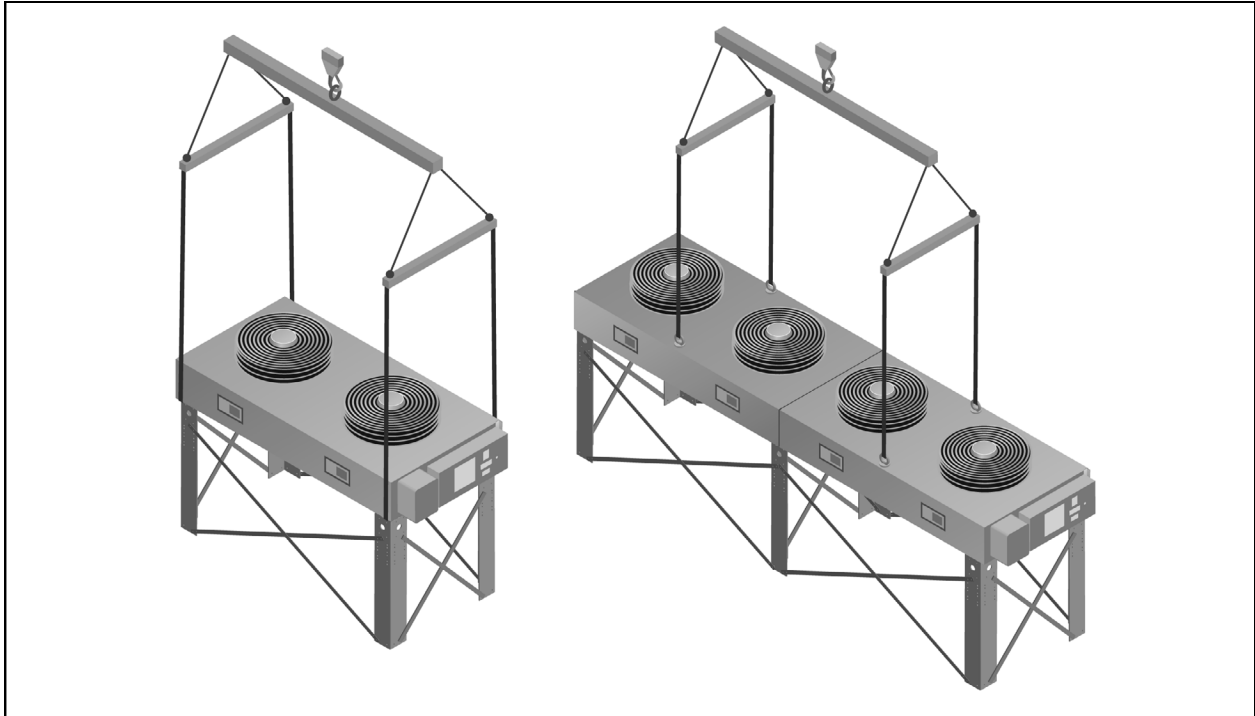
Figure 4.9 Rigging to Lift the Unit for Installation

4.6 Mounting the Condenser

The condenser must be installed so that it is level within 1/2 in. (13 mm) to ensure proper refrigerant flow. For roof installation, mount the condenser on suitable curbs or other supports. Follow all local and national codes.

4.6.1 Standard Mounting Requirements

Secure the legs to the mounting surface using field supplied 3/8 in. (9.5 mm) diameter grade 5 bolts with a flat washer in each of the two 1/2 in. x 1 in. (12.7 mm x 25.4 mm) obround holes in each leg. For anchor dimensions, see the appropriate planning dimension submittal documents for your unit included in the [Submittal Drawings](#) on page 91.

4.6.2 Seismic Certified and Wind Certified Mounting Requirements

Mounting requirement details such as anchor brand, type, embedment depth, edge spacing, anchor to anchor spacing, concrete strength, special inspection, and attachment to non-building structures must be outlined and approved by the engineer of record for the project or building.

Structural floors and housekeeping pads must also be designed and approved by the project or building structural engineer of record to withstand the seismic or wind anchor loads as defined on the installation drawings. The installing contractor is responsible for the proper installation of all anchors and mounting hardware, observing the mounting requirements detailed in the seismic or wind installation drawings and additionally outlined by the engineer of record.

At a minimum, 3/8 in. grade 5 anchors with American National Standard Series W, Type A, plain washers (ANSI B18.22.1-1965, R1975) selected to match the nominal anchor diameter must be installed at each anchor location between the anchor head and equipment for tension load distribution. See [Optional Configuration for Vertiv™ Liebert® MC Seismic Application or Wind Load Certification](#) on page 89, for additional information.

This page intentionally left blank

5 Piping

All refrigeration connections to the unit are sweat copper. Factory installed piping brackets must not be removed. Field installed piping must be installed in accordance with local codes and must be properly assembled, supported, isolated and insulated.

Refer to specific text and to the submittal documents included in the [Submittal Drawings](#) on page 91, for other unit specific piping requirements.

The following tables list the relevant documents by number and title.

Table 5.1 Piping Schematics Drawings

Document Number	Title
DPN002188	General Arrangement Diagram 600mm (24in) Air Cooled with Liebert® MC Models
DPN002858	General Arrangement Diagram 600mm (24in) Air Cooled with Liebert® MC Models
DPN002808	General Arrangement Diagram 300mm (12in) Air Cooled with Liebert® MC Models
DPN003730	Piping Schematic with Liebert® MC Condenser Air Cooled Scroll or Digital Scroll or Compressor Models
DPN004216	Piping Schematic with Liebert® MC Condenser Air Cooled DS077-105kW Semi-Hermetic Compressor Models
DPN002615	Piping Schematic DA050, DA080, DA085 Models with Liebert® MC
DPN002340	Piping Schematic DA125, DA150, DA165 with Liebert® MC
DPN002929	Piping Schematic Air Cooled Models with TXV
DPN003843	Piping Schematic Air Cooled Models with EEV

Table 5.2 Piping Connection Drawings

Document Number	Title
DPN002166	Piping Dimensional Data Single Circuit 1 Fan, 2 Fan, 3 Fan, and 4 Fan Units
DPN002167	Piping Locations Single Circuit with Liebert® Lee-Temp
DPN003839	Liebert® PDX-EEV Receiver Mounting MCS028, MCM040, and MCM080 Single Circuit Condenser Left Side Option
DPN002425	Piping Dimensional Data Dual Circuit 2 Fan and 4 Fan Units
DPN002426	Piping Dimensional Data with Liebert® Lee-Temp Dual Circuit Condensers

5.1 Refrigerant Piping and Charging



WARNING! Risk of over pressurization of the refrigeration system. Can cause explosive discharge of high pressure refrigerant, loss of refrigerant, environmental pollution, equipment damage, injury, or death. This unit contains fluids and gases under high pressure. Use extreme caution when charging the refrigerant system. Do not pressurize the system higher than the design pressure marked on the unit's nameplate.

Consult local building and plumbing codes for installation requirements of additional pressure relief devices when isolation valves are field installed. Do not isolate any refrigerant circuits from over pressurization protection.

NOTICE

Risk of oil contamination with water. Can cause equipment damage.

Polyolester oil (POE oil), required with R-407C/R-410A and used with some R-22 systems, is much more hygroscopic than mineral oils. This means that POE oil absorbs water at a much faster rate when exposed to air than previously used mineral oils. Because water is the enemy of a reliable refrigeration system, extreme care must be used when opening systems during installation or service. If water is absorbed into the POE oil, it will not be easily removed and will not be removed through the normal evacuation process. If the oil is too wet, it may require an oil change. POE oils also have a property that makes them act as a solvent in a refrigeration system. Maintaining system cleanliness is extremely important because the oil will tend to bring any foreign matter back to the compressor or plug the microchannel coil. Always use a flow of dry nitrogen when brazing.

5.1.1 Refrigerant Piping Guidelines for Air Cooled Systems

- Air cooled units and condensers ship with an inert gas holding charge. Do not vent the charge until all refrigerant piping is in place, ready for connection to the unit and condenser.
- Use copper piping with a brazing alloy with a minimum temperature of 1350°F (732°C), such as Sil-Fos. Avoid soft solders, such as 50/50 or 95/5.
- Use a flow of dry nitrogen through the piping during brazing to prevent formation of copper oxide scale inside the piping. When copper is heated in the presence of air, copper oxide forms. POE oils will dissolve these oxides from inside the copper pipes and deposit them throughout the system, clogging filter driers and affecting other system components.
- A pure dry nitrogen flow of 1-3 ft.³/min (0.5-1.5 l/s) inside the pipe during brazing is sufficient to displace the air. Control the flow using a suitable measuring device.
- Ensure that the tubing surfaces to be brazed are clean and that all burrs have been removed from the ends of the tubes.
- Ensure that all loose material has been cleaned from inside the tubing before brazing.
- Protect all refrigerant line components within 18 in. (460 mm) of the brazing site by wrapping them with a wet cloth or with a suitable heat sink compound.
- Isolate piping from building using vibration isolating supports.
- Consult factory if piping run exceeds 150 ft. (46 m) equivalent length on traditional R-407C Vertiv™ Liebert® DX units.
- Consult factory if piping run exceeds 300 ft. (91 m) equivalent length on traditional R-410A Liebert® DX units.
- Consult factory if piping run exceeds 300 ft. (91 m) actual length or 450 ft. (137.2 m) equivalent length on units with Vertiv™ Liebert® EconoPhase units.

- Install traps on hot gas (discharge) lines at the base of vertical risers over 5 ft. (1.5 m) and then for vertical rises over 25 ft. (7.6 m), install a trap in 20 ft. (6 m) increments or evenly divided over the vertical rise.
- Pitch horizontal hot gas piping down at a minimum rate of 1/2 in. per 10 ft. (42 mm per 10 m) so that gravity will aid in moving oil in the direction of refrigerant/oil flow.
- Keep piping clean and dry, especially on units with R-410A or R-407C refrigerant.
- Avoid piping runs through noise sensitive areas.
- Do not run piping directly in front of indoor unit discharge air stream.
- Refrigerant oil – do not mix oil types. Consult the indoor unit installation/user guide for refrigerant type and oil requirements.

Condenser with Receiver

- Cannot be installed below the evaporator.
- EEV units: The outlet of the receiver on the outdoor MC condenser must be higher than the elevation of the electronic expansion valves (EEV) inside the indoor unit. The vertical height of the receiver outlet must not exceed 60 ft. (18.3 m) above the EEV.
- TXV units: The bottom of the receiver on the outdoor MC condenser must be higher than the elevation of the thermal expansion valves (TXV) inside the indoor unit. The vertical height of the bottom of the receiver must not exceed 60 ft. (18.3 m) above the TXV.
- Consult factory before installing units, condensers, and receivers outside these parameters.
- Refer to DPN003954, DPN003993, and DPN003994 included in [Submittal Drawings](#) on page 91.

Condenser without Receiver

- The bottom of the condenser coil must be less than 15 ft. below the location of the TXV inside the indoor unit.
- The vertical height of the bottom of the condenser coil must not exceed 60 ft. (18.3 m) above the TXV inside the indoor unit.
- Consult factory before installing units and condensers outside these parameters.
- Refer to DPN003954 included in [Submittal Drawings](#) on page 91.

NOTE: Failure to use compressor oils recommended by compressor manufacturer will void compressor warranty. Consult Vertiv Technical Support or the compressor manufacturer for further recommendations or if you have questions about compressor oils.

Refer to ASHRAE Refrigeration Handbook for general, good practice refrigeration piping. The indoor cooling unit has a factory installed high pressure safety switch in the high side refrigerant circuit. A pressure relief valve is provided with Vertiv™ Liebert® Lee-Temp receivers and field installation is required. A fusible plug is installed in each Vertiv™ Liebert® DSE receiver and Vertiv™ Liebert® PDX-EEV receiver. An optional fusible plug kit is available for field installation on condensers without receivers.

NOTE: Liebert® DSE systems require all indoor and outdoor field refrigerant piping to be insulated 1/2 in. minimum. All outdoor insulation must be UV and ozone resistant.

- Refer to **Table 5.3** on the next page, for recommended refrigerant piping sizes based on equivalent pipe lengths.
- Refer to [Refrigerant Charge Requirements](#) on page 31, for the refrigerant charge requirements of the system.

5.1.2 Recommended Refrigerant Line Sizes

Table 5.3 Recommended Refrigerant Line Sizes for R-410A with Standard and Digital Scroll Compressors

Indoor Unit Model		Equivalent Length, ft. (m)				
		50 (15)	100 (30)	150 (45)	300 (91)	450 (137)
		Line sizes, OD Cu, in.				
CR019RA/ CR020RA	Hot Gas Line	3/4	3/4	3/4	7/8 ¹	—
	Liquid Line	5/8	5/8	5/8	3/4	—
CR035RA	Hot Gas Line	7/8	7/8	7/8	1-1/8 ¹	—
	Liquid Line	3/4	3/4	3/4	7/8	—
PX011	Hot Gas Line	1/2	5/8 ¹	5/8 ¹	5/8 ¹	—
	Liquid Line	3/8	1/2	1/2	1/2	—
PX018	Hot Gas Line	5/8	5/8	5/8	3/4 ¹	—
	Liquid Line	1/2	1/2	1/2	5/8	—
PX023	Hot Gas Line	3/4	3/4	3/4	7/8 ¹	—
	Liquid Line	5/8	5/8	5/8	5/8	—
PX029	Hot Gas Line	7/8	7/8	7/8	1-1/8 ¹	—
	Liquid Line	5/8	5/8	5/8	3/4	—
DA050/ DA080/ DA085	Hot Gas Line	1-1/8	1-1/8	1-1/8	1-1/8	1-1/8 ²
	Liquid Line	7/8	7/8	7/8	7/8	7/8 ²
DA125	Hot Gas Line	1-3/8	1-3/8	1-3/8	1-3/8	1-3/8 ²
	Liquid Line	7/8	7/8	7/8	7/8	7/8 ²
DA150	Hot Gas Line	1-3/8	1-3/8	1-3/8	1-3/8	1-3/8 ²
	Liquid Line	7/8	1-1/8	1-1/8	1-1/8	1-1/8 ²
DA165	Hot Gas Line	1-3/8	1-3/8	1-3/8	1-3/8	1-3/8 ²
	Liquid Line	7/8	1-1/8	1-1/8	1-1/8	1-1/8 ²

Consult factory for proper line sizing for piping runs longer than the listed maximum equivalent length.

1. Downsize vertical riser one trade size (1-1/8" to 7/8" or 7/8" to 3/4" or 5/8" to 1/2").

2. Consult the factory when actual pipe length between condenser/Vertiv™ Liebert® EconoPhase and Vertiv™ Liebert® DSE unit will exceed 300 ft. (91 m).

Source: DPN000788 Rev. 13

Table 5.4 Recommended Refrigerant Line Sizes for R-407C by Compressor Type

Indoor Unit Model	Compressor Type:	Standard (Non-digital) Scroll			4 Step Semi-hermetic or Digital Scroll		
	Equivalent Length, ft. (m):	50 (15)	100 (30)	150 (45)	50 (15)	100 (30)	150 (45)
		Line sizes, OD Cu, in.					
DS035	Hot Gas Line	7/8	7/8	7/8	3/4	7/8	7/8
	Liquid Line	1/2	5/8	5/8	1/2	5/8	5/8
DS042	Hot Gas Line	7/8	7/8	7/8	7/8	7/8	1-1/8 ¹
	Liquid Line	1/2	5/8	5/8	5/8	5/8	5/8
DS053	Hot Gas Line	7/8	1-1/8	1-1/8	7/8	1-1/8 ¹	1-1/8 ¹
	Liquid Line	5/8	7/8	7/8	5/8	7/8	7/8
DS070	Hot Gas Line	1-1/8	1-1/8	1-1/8	1-1/8 ¹	1-1/8 ¹	1-1/8 ¹
	Liquid Line	7/8	7/8	7/8	7/8	7/8	7/8
DS077 ²	Hot Gas Line	1-1/8	1-1/8	1-1/8	1-1/8	1-1/8	1-1/8
	Liquid Line	7/8	7/8	7/8	7/8	7/8	7/8
DS105 ²	Hot Gas Line	1-3/8	1-3/8	1-3/8	1-3/8	1-3/8	1-3/8
	Liquid Line	7/8	7/8	1-1/8	7/8	7/8	1-1/8

Consult factory for proper line sizing for runs longer than maximum equivalent length listed.

1. Downsize vertical riser one trade size (1-1/8" to 7/8").

2. Digital scroll not available on 077 and 105 models.

Source: DPN000788 Rev. 13

5.1.3 Refrigerant Charge Requirements

To calculate the charge requirements:

1. Determine the charge for your units by model number from the following tables and the tables in the indoor unit's installer/user guide.
2. Determine the charge for the piping by line size and length.
3. Add these all together to obtain the total refrigerant charge for your system.

These values can be used for obtaining adequate refrigerant for the system, but should not be used for final charging.

NOTE: Due to the much smaller coil volume, the performance, especially sub-cooling, of a Vertiv™ Liebert® MC condenser is quite sensitive to the amount of refrigerant charge. Ensure that an accurate amount of refrigerant charge is added.

Table 5.5 Approximate Refrigerant Required, R-410A

Condenser Models	Single Circuit Condensers			Dual Circuit Condensers		
	Condensers without Receivers or Liebert® Lee-Temp	Condensers with Liebert® Lee-Temp	Condensers with Liebert® DSE or Liebert® PDX-EEV Small Receiver/Large Receiver*	Condensers without Receivers or Liebert® Lee-Temp	Condensers with Liebert® Lee-Temp	Condensers with Liebert® DSE Small Receiver/Large Receiver*
	Approximate R-410A Refrigerant Needed, lb/circuit (kg/circuit)					
MCS028	2.5 (1.2)	21.7 (9.8)	11.0 (5.0)	—	—	—
MCS056	—	—	—	2.5 (1.2)	21.7 (9.8)	—
MCM040	3.5 (1.6)	22.7 (10.3)	12.0 (5.4)	—	—	—
MCM080	8.5 (3.8)	39.8 (18.1)	17.0 (7.7)	3.5 (1.6)	22.7 (10.3)	—
MCM160	—	—	—	8.5 (3.8)	39.8 (18.1)	17 (7.7) / 24 (10.9)
MCL055	5.0 (2.3)	24.2 (11.0)	13.5 (6.1)	—	—	—
MCL110	10.7 (4.9)	49.1 (22.3)	19.5 (8.8)	5.2 (2.4)	24.4 (11.1)	14.0 (6.4)
MCL165	18.4 (8.4)	79.9 (36.2)	27.0 (12.2) / 34.0 (15.4)	—	—	—
MCL220	27.0 (12.3)	102.9 (46.7)	42.5 (19.3)	12.3 (5.6)	50.7 (23.0)	21.0 (9.5) / 28.0 (12.7)

*Small receiver (28 in. long) is used with DA050, DA080 and DA085; large receiver (60 in. long) is used with DA125, DA150 and DA165.
Source: DPN002411, Rev. 8

Table 5.6 Approximate Refrigerant Required, R-407C

Condenser Model	Single Circuit Condensers		Dual Circuit Condensers	
	Condensers without Liebert® Lee-Temp	Condensers with Liebert® Lee-Temp	Condensers without Liebert® Lee-Temp	Condensers with Liebert® Lee-Temp
	Approximate R-407C Refrigerant Needed, lb/circuit (kg/circuit)			
MCS028	2.2 (1.0)	23.1 (10.5)	—	—
MCS056	—	—	2.2 (1.0)	23.1 (10.5)
MCM040	3.0 (1.4)	23.9 (10.8)	—	—
MCM080	7.5 (3.4)	44.5 (20.2)	3.0 (1.4)	23.9 (10.8)
MCM160	—	—	7.5 (3.4)	44.5 (20.2)
MCL055	5.0 (2.3)	25.9 (11.7)	—	—
MCL110	10.5 (4.8)	52.1 (23.7)	5.1 (2.3)	26.0 (11.8)
MCL165	18.3 (8.3)	84.8 (38.5)	—	—
MCL220	27.0 (12.3)	108.9 (49.4)	12.2 (5.6)	53.8 (24.4)

Source: DPN002411, Rev. 8

Table 5.7 Interconnecting Piping Refrigerant Charge, lb/100 ft. (kg/30m)

Line Size O.D., in.	R-407C		R-410A	
	Hot Gas Line	Liquid Line	Hot Gas Line	Liquid Line
3/8	—	3.6 (1.6)	—	3.2 (1.4)
1/2	0.5 (0.2)	6.7 (3.0)	0.7 (0.3)	5.9 (2.7)
5/8	0.8 (0.4)	10.8 (4.8)	1.1 (0.5)	9.6 (4.3)
3/4	1.2 (0.5)	16.1 (7.2)	1.6 (0.7)	14.3 (6.4)
7/8	1.7 (0.8)	22.3 (10.0)	2.3 (1.0)	19.8 (8.8)
1-1/8	2.9 (1.3)	38.0 (17.0)	3.9 (1.7)	33.8 (15.1)
1-3/8	4.4 (2.0)	57.9 (25.9)	5.9 (2.6)	51.5 (23.0)
1-5/8	6.2 (2.8)	—	8.4 (3.7)	—

Data based on 50°F Evap, 15°F superheat, 125°F SCT, 10°F sub-cooling
Source: DPN002411, Rev. 8

5.1.4 System Refrigerant Pressures

Table 5.8 System Refrigerant Pressures

Maximum Design Operating Pressure (High Side)	R-407C		R-410A		Noted on the unit serial tag.
	364 psig	2510 kPa	530 psig	3655 kPa	

5.1.5 Additional Oil Requirements

Refer to the indoor unit's installer/user guide to determine if additional oil is required for each circuit. The need for additional oil is affected by compressor type, piping lengths, receiver, and total refrigerant charge.

5.2 Equipment Application Guidelines

Pump down must be disabled on the indoor unit when using the Vertiv™ Liebert® MC condenser, due to the reduced volume in the condenser coil.

We recommend adding a discharge line check valve and crankcase heater when connecting the Liebert® MC condenser to Liebert indoor units built before 2012. The check valve and crankcase heater are needed for compressor protection. Additional liquid line Schrader ports are required at the indoor unit to properly charge systems with Liebert® MC condensers.

5.3 System Dehydration/Leak Test

Refer to the indoor unit's installer/user guide for the leak check and evacuation procedures for the entire thermal management system. Refer to the section regarding the winter control system used on the condenser.

5.4 Charging for Condensers with Vertiv™ Liebert® Lee-Temp Receivers

Consult the indoor unit's installer/user guide for charging systems with Liebert® Lee-Temp receivers. These procedures are identical to systems with fin/tube condenser coils, but the refrigerant volumes will be much lower.

5.5 Charging for Condensers with Vertiv™ Liebert® PDX-EEV Receivers

Refer to the Liebert® PDX/PCW Installer/User Guide for the leak check and evacuation procedures for the entire thermal management system. All Liebert® PDX units with EEV require either a heated Vertiv™ Liebert® Lee-Temp receiver or an unheated Liebert® PDX EEV receiver.

5.6 Charging for Condensers with Vertiv™ Liebert® DSE Receivers

Refer to the Liebert® DSE Installer/User Guide for the leak check and evacuation procedures for the entire thermal management system. All Liebert® DSE Thermal Management Systems require a DSE receiver on each condenser circuit whether or not the system includes a Vertiv™ Liebert® EconoPhase pump module.

5.7 Charging for Condensers without Receivers

Consult the indoor unit's installer/user guide for charging systems without receivers. Vertiv™ Liebert® MC condensers are charge sensitive and require accurate calculation of system charge to avoid over-charging.

6 Electrical Connections

Line voltage electrical service is required for all models. Electrical service must conform to national and local electrical codes. Refer to equipment nameplate regarding wire size and circuit protection requirements. Refer to electrical schematic when making connections. Refer the appropriate submittal drawing, listed in **Table 6.1** on the next page, for electrical service entrances into unit.

A manual electrical disconnect switch should be installed in accordance with local codes and distribution system. Consult local codes for external disconnect requirements.

All internal wiring is completed at the factory.



WARNING! Arc flash and electric shock hazard. Open all local and remote electric power supply disconnect switches, verify with a voltmeter that power is Off and wear appropriate, OSHA approved personal protective equipment (PPE) per NFPA 70E before working within the electric control enclosure. Failure to comply can cause serious injury or death. Customer must provide earth ground to unit, per NEC, CEC and local codes, as applicable. Before proceeding with installation, read all instructions, verify that all the parts are included and check the nameplate to be sure the voltage matches available utility power. The Vertiv™ Liebert® iCOM™ controller does not isolate power from the unit, even in the “Unit Off” mode. Some internal components require and receive power even during the “Unit Off” mode of the Liebert® iCOM™ controller. The factory supplied disconnect switch is inside the unit. The line side of this switch contains live high voltage. The only way to ensure that there is NO voltage inside the unit is to install and open a remote disconnect switch. Refer to unit electrical schematic. Follow all local codes.



WARNING! Risk of improper wiring, piping, moving, lifting and handling. Can cause equipment damage, serious injury or death. Installation and service of this equipment should be done only by qualified personnel who have been specially trained in the installation of air conditioning equipment and who are wearing appropriate, OSHA approved PPE.



WARNING! Risk of improper wire sizing/rating and loose electrical connections. Can cause overheated wire and electrical connection terminals resulting in smoke, fire, equipment and building damage, injury or death. Use correctly sized copper wire only and verify that all electrical connections are tight before turning power On. Check all electrical connections periodically and tighten as necessary.

NOTICE

Risk of improper power supply connection. Can cause equipment damage and loss of warranty coverage.

Prior to connecting any equipment to a main or alternate power source (for example: backup generator systems) for startup, commissioning, testing, or normal operation, ensure that these sources are correctly adjusted to the nameplate voltage and frequency of all equipment to be connected. In general, power source voltages should be stabilized and regulated to within $\pm 10\%$ of the load nameplate nominal voltage. Also, ensure that no three phase sources are single phased at any time.

NOTE: Use copper wiring only. Make sure that all connections are tightened to the proper torque mentioned on the component.

NOTE: Installation and service of this equipment should be done only by properly trained and qualified personnel who are specially trained in the installation of air conditioning equipment.

The electrical connections are described in the submittal documents included in the [Submittal Drawings](#) on page 91.

The following tables list the relevant documents by number and title.

Table 6.1 Electrical Field Connection Drawings

Document Number	Title
DPN002169	Electrical Field Connections Premium Efficiency Control
DPN002374	Electrical Field Connections Premium Efficiency Control with Liebert® Lee-Temp
DPN003284	CANbus and Interlock Connections Using 1 Liebert® MC Condenser and Optional Liebert® EconoPhase Unit
DPN002361	CANbus and Interlock Connections Using 2 Liebert® MC Condensers and Optional Liebert® EconoPhase Unit
DPN003267	CANbus and Interlock Connections between Liebert® DS and Liebert® MC Condenser (Premium)
DPN002841	CANbus and Interlock Connections between 600mm (24in) and Liebert® MC (Premium)
DPN003036	CANbus and Interlock Connections between 300mm (12in) Unit and Liebert® MC (Premium)
DPN003266	CANbus and Interlocking Connections between Liebert® PDX Unit and Liebert® MC Condenser (Premium)
DPN003047	Electrical 575V Option
DPN002960	Surge Protective Device Options

6.1 Line Voltage Wiring



WARNING! Risk of electrical fire and short circuit. Can cause property damage, injury or death. Select and install the line side electrical supply wire and overcurrent protection device(s) according to the specifications on the unit nameplate(s), per the instructions in this manual and according to the applicable national, state and local code requirements. Use copper conductors only. Verify that all electrical connections are tight. Unit specific wiring diagrams are provided on each unit.

NOTICE

Risk of improper power supply connection. Can cause equipment damage and loss of warranty coverage.

Prior to connecting any equipment to a main or alternate power source (for example: backup generator systems) for startup, commissioning, testing, or normal operation, ensure that these sources are correctly adjusted to the nameplate voltage and frequency of all equipment to be connected. In general, power source voltages should be stabilized and regulated to within $\pm 10\%$ of the load nameplate nominal voltage. Also, ensure that no three phase sources are single phased at any time.

NOTE: For acceptable and unacceptable power supplies, see [Wye vs. Delta Connected Power Supply](#) on page 40 .

Condenser rated voltage should be verified with available power supply before installation. Refer to the unit's electrical schematic and serial tag for specific electrical requirements.

Vertiv™ Liebert® MC condenser power connections are provided for three-phase wires and 1 earth ground wire. Line voltage electrical service is required for all condensers at the location of the condenser. The voltage supply to the condenser may not be the same voltage supply as required by the indoor unit. Consider using a UPS on both indoor cooling units and Liebert® MC condensers to maintain uninterrupted cooling capability. Refer to the unit's serial tag for specific condenser electrical requirements. A unit disconnect is standard. However, a site disconnect may be required by local code to isolate the unit for maintenance. Route the supply power to the site disconnect switch and then to the unit. Route the conduit to the knockout provided in the bottom-right end of the electrical control enclosure. Connect the earth ground wire lead to the marked earth ground connection terminal provided near the factory installed disconnect switch per the appropriate drawing in the [Submittal Drawings](#) on page 91 .

NOTE: A separate neutral wire does not need to be run to the Liebert® MC condenser.

6.2 Electrical Power Requirements

Table 6.2 on the next page lists the power requirements by model number and size. **Table 6.3** on page 39 lists the additional electrical requirements if your system includes a Vertiv™ Liebert® Lee-Temp receiver.

Table 6.2 Electrical Data, Three-Phase, 60 Hz Condenser, Premium EC Fan Control

Model	Voltage	FLA	WSA	OPD
Small Platform				
MCS028	208/230V	3.0	3.8	15
	380V	1.4	1.8	15
	460V	1.4	1.8	15
	575V	1.2	1.5	15
MCS056	208/230V	6.0	6.8	15
	380V	2.8	3.2	15
	460V	2.8	3.2	15
	575V	2.4	2.7	15
Medium Platform				
MCM040	208/230V	2.3	2.9	15
	380V	1.4	1.8	15
	460V	1.4	1.8	15
	575V	1.2	1.5	15
MCM080	208/230V	4.6	5.2	15
	380V	2.8	3.2	15
	460V	2.8	3.2	15
	575V	2.4	2.7	15
MCM160	208/230V	9.2	9.8	15
	380V	5.6	6.0	15
	460V	5.6	6.0	15
	575V	4.8	5.1	15

Table 6.2 Electrical Data, Three-Phase, 60 Hz Condenser, Premium EC Fan Control (continued)

Model	Voltage	FLA	WSA	OPD
Large Platform				
MCL055	208/230V	5.7	7.1	15
	380V	2.8	3.5	15
	460V	2.8	3.5	15
	575V	2.3	2.9	15
MCL110	208/230V	11.4	12.8	15
	380V	5.6	6.3	15
	460V	5.6	6.3	15
	575V	4.7	5.3	15
MCL165	208/230V	17.1	18.5	20
	380V	8.4	9.1	15
	460V	8.4	9.1	15
	575V	7.0	7.6	15
MCL220	208/230V	22.8	24.2	25
	380V	11.2	11.9	15
	460V	11.2	11.9	15
	575V	9.4	9.9	15
<ol style="list-style-type: none"> 1. FLA = Full Load Amps; WSA = Wire Size Amps; OPD = Maximum Overcurrent Protection Device. 2. Refer to Wye vs. Delta Connected Power Supply on page 1, for acceptable power supply configurations. 				
Source: DPN005027 Rev. 0				

Table 6.3 Electrical Data, Vertiv™ Liebert® Lee-Temp Receiver, 60 Hz

Rated Voltage Single Phase	120		208/230	
	Watts/Receiver	150	300	150
Amps	1.4	2.8	0.7	1.4
Wire Size Amps	1.8	3.5	0.9	1.8
Maximum Overcurrent Protection Device, Amps	15	15	15	15
<ol style="list-style-type: none"> 1. The Liebert® Lee-Temp receiver requires a separate power feed for heaters. 2. The condenser is not designed to supply power to the receiver heater pads. 3. The Liebert® Lee-Temp system allows system start-up and positive head pressure control in outdoor temperature as low as -30°F (-34°C). 				

6.3 Wye vs. Delta Connected Power Supply

Acceptable Power Supplies—208 V to 575 V Nominal Units

- 208 V Wye with solidly-grounded neutral and 120 V line to ground
- 380 V Wye with solidly-grounded neutral and 220 V line to ground
- 480 V Wye with solidly-grounded neutral and 277 V line to ground
- 575 V Wye with solidly-grounded neutral and 322 V line to ground (uses step down transformers)
- Wye with high resistance (or impedance) ground
- Delta with corner ground

Unacceptable Power Supplies

- Delta without ground or with floating ground
- Delta with grounded center tap

6.4 Low Voltage Control Wiring—CANbus Communication

NOTICE

Risk of control malfunction. Can cause improper unit operation.

Verify that all low voltage electrical wiring has been performed per the schematic diagram provided and that all low voltage wiring connections are tight.

CANbus communication and interlock wiring are required between the indoor and the outdoor units. CANbus cables are supplied by others to connect the indoor unit to the outdoor condenser. No special considerations are required when the total external cable connection between the indoor unit and outdoor unit is less than 450 ft. (137 m). A CANbus isolator is required for total external cable connections longer than 450 ft. (137 m) but less than 800 ft. (243 m).

The control wiring connections are described in the submittal documents included in the [Submittal Drawings](#) on page 91.

The following tables list the relevant documents by number and title.

Table 6.4 CANbus Communication Connection Drawings

Document Number	Title
DPN003267	CANbus and Interlock Connections between Liebert® DS and Liebert® MC Condenser (Premium)
DPN003266	CANbus and Interlock Connections between Liebert® PDX Unit and Liebert® MC Condenser (Premium)
DPN002841	CANbus and Interlock Connections between 600mm (24in) and Liebert® MC (Premium)
DPN003036	CANbus and Interlocking Connections between Liebert® PDX Unit and Liebert® MC Condenser (Premium)
DPN003284	CANbus and Interlock Connections Using 1 Liebert® MC Condenser and Optional Liebert® EconoPhase Unit
DPN002361	CANbus and Interlock Connections Using 2 Liebert® MC Condensers and Optional Liebert® EconoPhase Unit

7 Checklist for Completed Installation

7.1 Moving and Placing Equipment

1. Unpack and check received material.
2. Proper clearance for service access has been maintained around the equipment.
3. Equipment is level and mounting fasteners are tight.

7.2 Electrical Installation Checks

1. Line voltage connected and matches equipment nameplate.
2. Power line circuit breakers or fuses have proper ratings for equipment installed.
3. CANbus communication and interlock wiring connections completed between indoor cooling unit and condenser.
4. All internal and external high and low voltage wiring connections are tight.
5. Confirm that unit is properly grounded to an earth ground.
6. Control transformer setting matches incoming power.
7. Electrical service conforms to national and local codes.
8. Verify that the condenser is not connected to an unacceptable power supply, see [Wye vs. Delta Connected Power Supply](#) on page 40 .
9. Verify that the CANbus wiring, CANbus END of Line jumper position, and the CANbus Device Address DIP Switch setting are correct according to the application at the job site.
10. Verify that terminals 70, 71, (and 230 when applicable) are used and properly wired for interlock wiring, particularly on systems that use two condensers for one indoor unit.

7.3 Piping Installation Checks

1. Piping completed to corresponding indoor cooling unit refrigeration circuit.
2. Piping is leak checked, evacuated and charged with specified refrigerant.
3. Additional refrigerant oil is added per circuit, if required.
4. Piping is properly sized, sloped, and trapped for proper oil return.
5. Check piping inside and outside of equipment for proper support and adequate spacing to prevent rub through or chafing.
6. Hot gas line on Vertiv™ Liebert® Lee-Temp receiver is fastened to the side of the cabinet and isolated for vibration reduction, if applicable.

7.4 Other Installation Checks

1. Installation materials and tools have been removed from equipment (literature, shipping materials, construction materials, tools, etc.).
2. Locate blank startup sheet, ready for completion by installer or startup technician.

This page intentionally left blank

8 Initial Startup Checks and Commissioning Procedure for Warranty Inspection



WARNING! Arc flash and electric shock hazard. Open all local and remote electric power supply disconnect switches, verify with a voltmeter that power is Off and wear appropriate, OSHA approved personal protective equipment (PPE) per NFPA 70E before working within the electric control enclosure. Failure to comply can cause serious injury or death. Customer must provide earth ground to unit, per NEC, CEC and local codes, as applicable. Before proceeding with installation, read all instructions, verify that all the parts are included and check the nameplate to be sure the voltage matches available utility power. The Vertiv™ Liebert® iCOM™ controller does not isolate power from the unit, even in the “Unit Off” mode. Some internal components require and receive power even during the “Unit Off” mode of the Liebert® iCOM™ controller. The factory supplied disconnect switch is inside the unit. The line side of this switch contains live high voltage. The only way to ensure that there is NO voltage inside the unit is to install and open a remote disconnect switch. Refer to unit electrical schematic. Follow all local codes.



WARNING! Risk of improper wiring, piping, moving, lifting and handling. Can cause equipment damage, serious injury or death. Installation and service of this equipment should be done only by qualified personnel who have been specially trained in the installation of air conditioning equipment and who are wearing appropriate, OSHA approved PPE.



WARNING! Risk of contact with high speed rotating fan blades. Can cause serious injury or death. Open all local and remote electric power supply disconnect switches, verify with a voltmeter that power is off, and verify that all fan blades have stopped rotating before working in the unit cabinet or on the fan assembly. If control voltage is applied, the fan motor can restart without warning after a power failure. Do not operate the unit with any or all cabinet panels removed.



CAUTION: Risk of exposure to harmful noise levels. Can cause hearing injury or loss. Depending on the installation and operating conditions, a sound pressure level greater than 70 dB(A) may arise. Take appropriate technical safety measures. Operating personnel must wear appropriate, OSHA approved PPE and observe all appropriate hearing protection safety requirements.

- Confirm that all items on [Checklist for Completed Installation](#) on page 41 have been done.
- Locate the Liebert® MC Warranty Inspection Check Sheet in the unit’s electric panel (PSWI-8542-408CO).
- Complete the Liebert® MC Warranty Inspection Check Sheet during start-up (PSWI-8542-408CO).
- Forward the completed Liebert® MC Warranty Inspection Check Sheet to your local sales office. **This information must be completed and forwarded to validate warranty.**
- Contact your local sales representative or technical support if you have any questions or problems during unit start-up and commissioning. Visit <https://www.Vertiv.com/en-us/support/> or call 1-800-543-2778 for contacts.

This page intentionally left blank

9 Troubleshooting

When an EconoPhase unit triggers an alarm, please refer to the *Vertiv™ Liebert® EconoPhase Installer/User Guide* available on the product page at www.Vertiv.com.

Table 9.1 Troubleshooting

Symptom	Possible cause	Check or Remedy
Condenser will not start	No power to condenser.	Check voltage at input terminal block.
	Circuit breaker or fuse for low voltage transformer in condenser is tripped.	Locate problem in condenser electrical panel and repair.
	No low voltage signal to/from indoor unit.	Locate open circuit and repair.
Low discharge pressure	Faulty head pressure control valve or premium efficiency control board.	Replace if defective.
High discharge pressure	Dirty condenser fins.	Clean coil.
	Condenser fans not operating.	Check for low voltage signal from indoor unit.
		Check fan motors and fuses.
High refrigerant charge	Check refrigerant charge.	
SPD green and red LEDs are extinguished	No voltage or improper phasing exists at condenser.	Check voltage at input terminal block.
	Electrical connections to SPD are faulty.	Locate connection problem and repair.
	Condenser disconnect is turned Off.	Recheck lights with disconnect switch in the On position.
SPD red LED is illuminated	A surge exceeding the rating of the SPD has occurred.	Replace SPD and inspect other components for damage and replace them, if necessary.
Control Board LEDs do not light.	Connection to P24 is loose or disconnected.	Check the connection to P24 to verify that is connected securely. Check the connector from the transformer for loose terminals.
	Fuse located next to P24 has blown.	Verify that the fuses next to P24 have not blown. Replace as needed.
	24V transformer has failed.	With a voltmeter verify that the output from the transformer is 24Vac \pm 10%. If the value exceeds \pm 10%. Verify that the correct primary leads are being used.
	Premium Efficiency Control Board has failed.	If there is no output voltage, verify that the primary connections are secure and receiving the correct voltage. If they are, replace the transformer.
Fan will not run	Jumper not installed between 24V and DIN1 (for Ziehl-Abegg fan motor).	Install jumper between 24V and DIN1 (for Ziehl-Abegg fan motor).

This page intentionally left blank

10 Control Operation

The Vertiv™ Liebert® MC Premium Efficiency Control takes about 30 seconds to boot during which time, the LED on the Premium Efficiency Control Board reads “888.” When fully booted, “F00” displays, then the value for F00. When using the control, the condenser fan(s) respond less than five seconds after receiving a "compressor-on" signal from the indoor unit. Consider using UPS equipment on both data center cooling units and Liebert® MC condensers to maintain uninterrupted cooling capability.

For the first 60 seconds of operation after the compressor turns on, the condenser fan(s) run at a factory set fixed speed, based on ambient temperature: faster at higher temperatures, slower at lower temperatures. After 60 seconds, the control adjusts the fan speed based on the liquid pressure transducer. If the liquid pressure transducer fails, the condenser uses temperature sensors to control the fan speed based on the liquid line temperature. The condenser fans continue to operate for approximately 30 seconds after compressors turn Off.

The Liebert® MC fans have various alarm conditions, such as loss of voltage and loss of control signal, that stop the condenser fans. When an alarm condition is no longer present the fans turn on automatically if compressors are On.

10.1 Premium Efficiency Control Board and Interface

The Premium Efficiency Control board has a stacked board arrangement. The human machine interface consists of three, 7-segment LEDs and keys (see **Figure 10.2** on the next page).

NOTE: Indicator lights should be On to indicate signal is present. See Figure 10.1 on the next page .

The Premium Efficiency Controls are factory configured for refrigerant type, whether or not a receiver is included, and the indoor cooling unit. No field configuration is necessary for proper and efficient condenser operation.

Figure 10.1 Premium Efficiency Fan Control Board

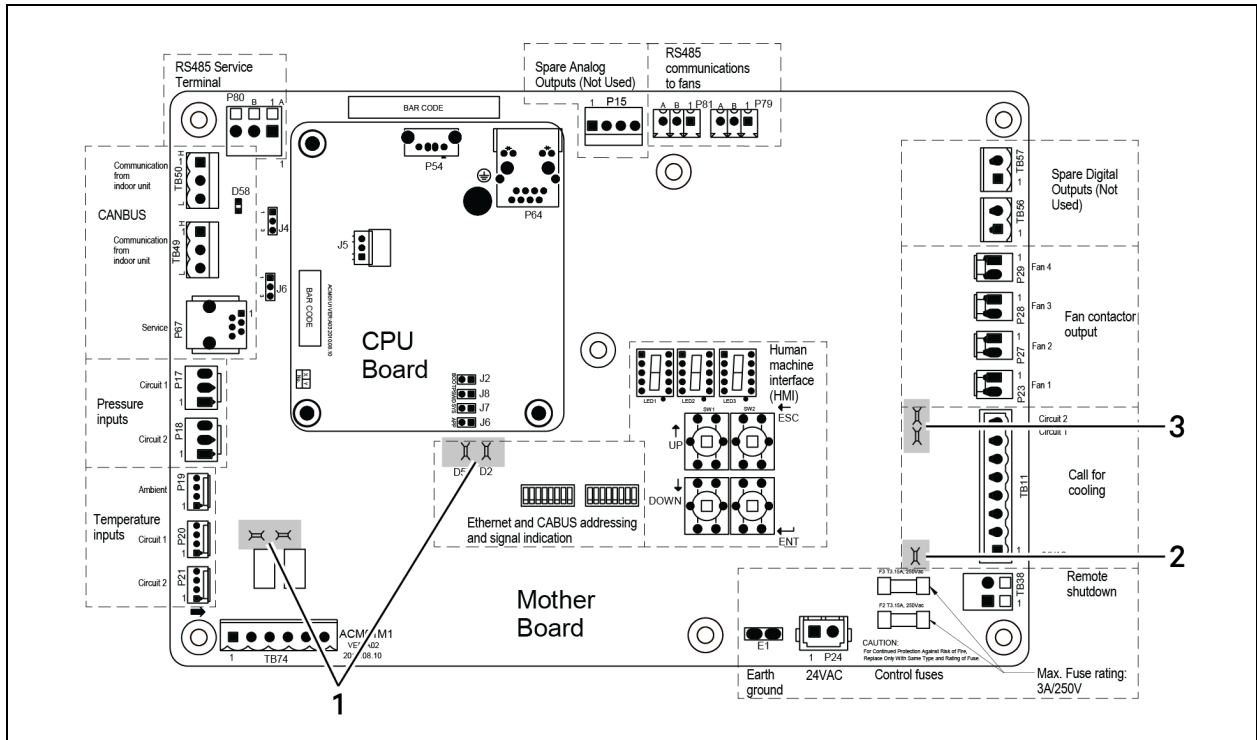

Item	Description
1	LED indicates signal is present when lit.
2	LED indicates signal is present when lit.
3	LED indicates signal is present when lit.

Figure 10.2 Control Board HMI

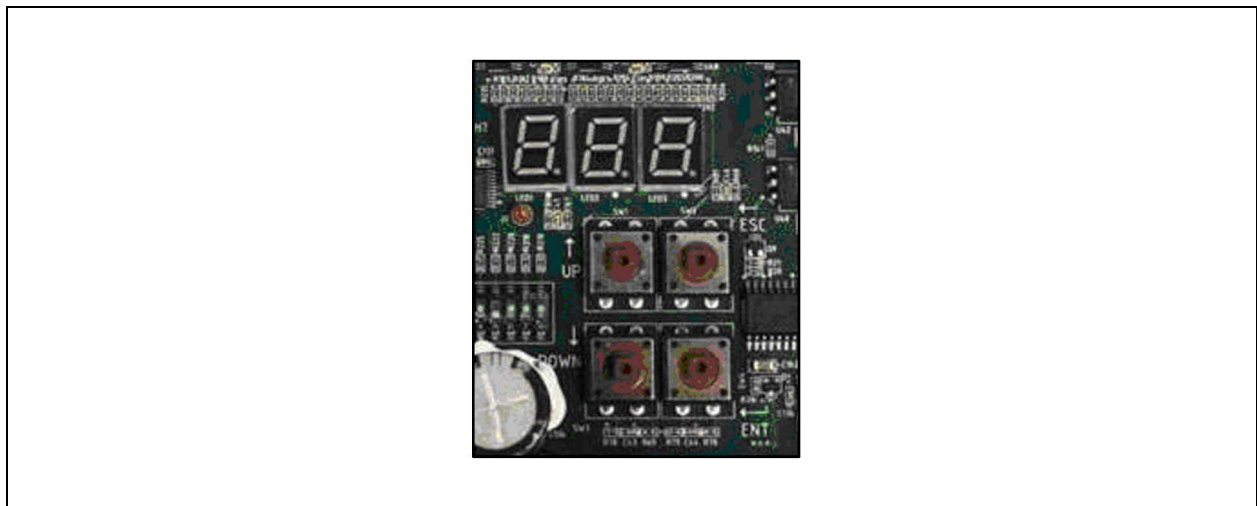

10.1.1 Initial Display upon Power On

After power on, first item of the analog signals menu displays. *F00* and the pressure value of condenser 1 display alternately. *F00* is the item ID of Condenser Pressure 1, see **Table 10.1** on page 52, for the description of the analog signal item IDs.

Figure 10.3 below, shows the alternating ID and example compressor 1 pressure of 16.1.

Figure 10.3 Initial Display on the Controller



10.1.2 Navigating the Controller Interface Main Menu

At the initial display, press **ESC** to display the first item of the main menu, which includes four options:

- Analog Signals Menu
- Active Alarms Menu
- History Alarms Menu
- Configuration Menu

Use the Up and Down keys to scroll through the menus, and press **ENT** to enter the sub-menus. **Figure 10.4** below, shows the operation and structure of the main menu.

Figure 10.4 Main Menu Operation and Structure

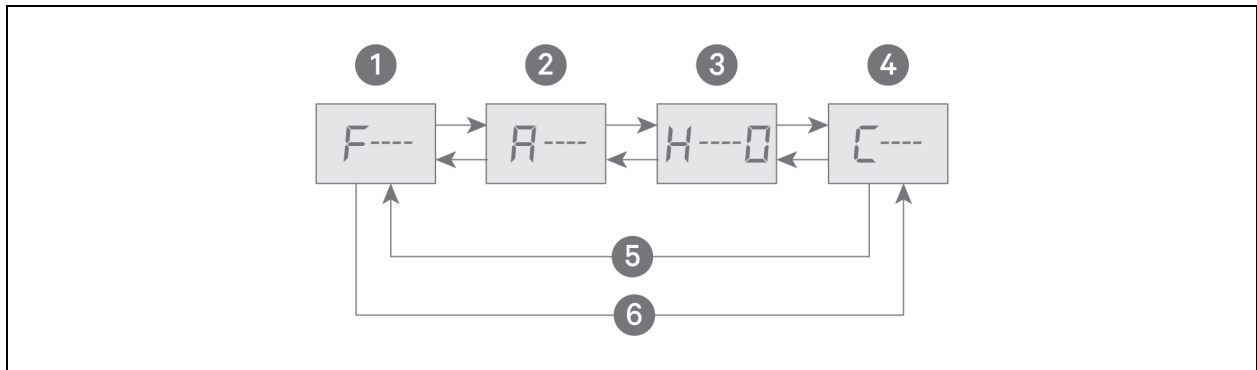

Item	Description
1	Analog signals menu
2	Active alarms menu
3	History alarms menu
4	Configuration menu
5	Pressing up arrow from analog signals displays the configuration menu.
6	Pressing down arrow from configuration menu displays the analog signals menu.

NOTICE

Risk of improperly altered configuration menu settings. Can compromise equipment operation.

Changing the configuration menu settings can cause unanticipated results. These settings should be changed only by properly trained and qualified personnel or as directed by the factory.

10.1.3 Analog Signals Menu

In the analog signals menu, F--, press ENT to enter the analog signal items described in **Table 10.1** on page 52. The item ID and signal value display alternately. **Figure 10.5** on the facing page, shows the operation and item structure of the analog signals menu.

Figure 10.5 Analog Signals Menu

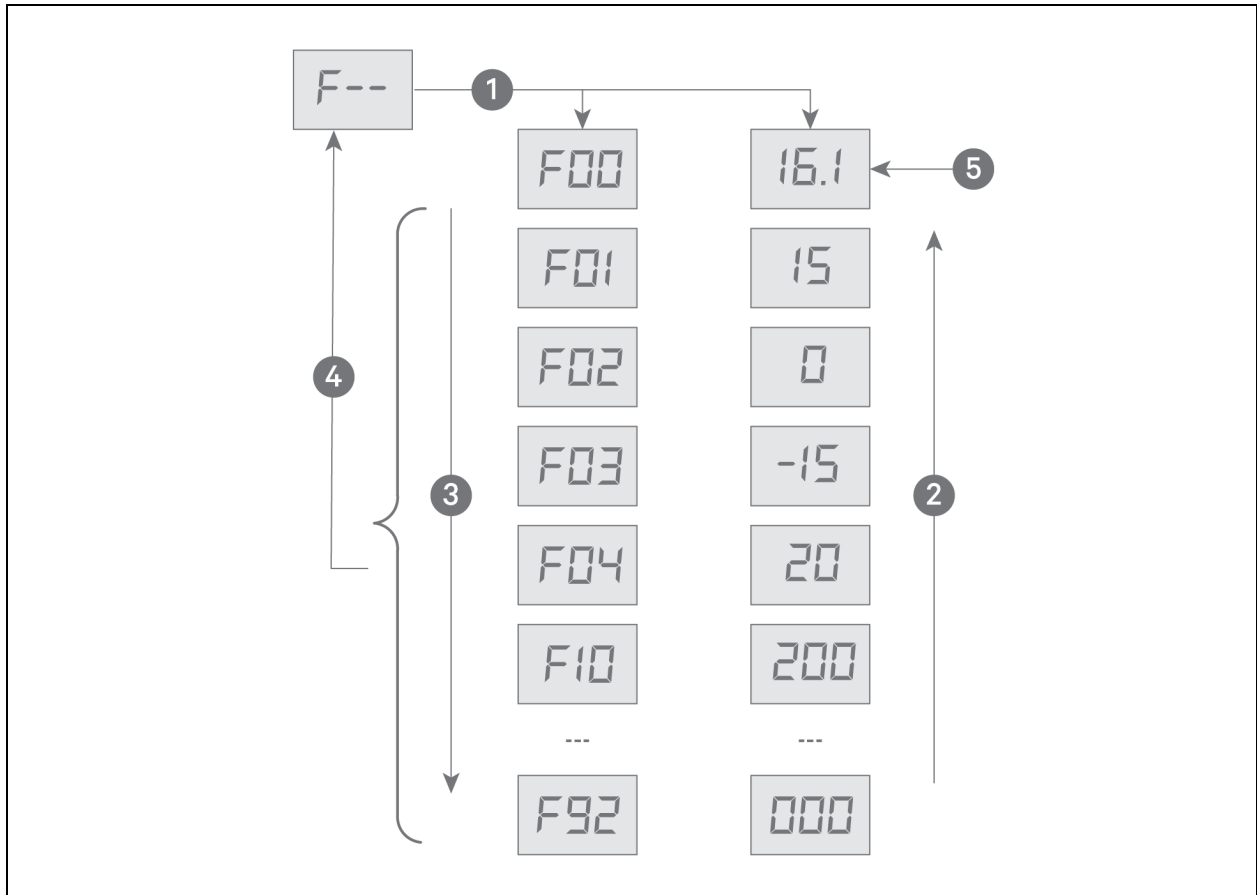

Item	Description
1	Pressing ENT displays the first analog signal item which alternately displays the ID and the reading.
2	Pressing up arrow, cycles "up" through the menu items/readings.
3	Pressing down arrow, cycles "down" through the menu items/readings.
4	Pressing ESC returns to the analog signals menu.
5	Initial screen, item F00 with example 16.1 reading.
6	Down from configuration menu displays the analog signals menu.

Table 10.1 Analog Signal Definitions

Item ID	Meaning	Units (C90)	
		Imperial	Metric
F00	Condenser pressure 1	psi	bar
F01	Condenser pressure 2	psi	bar
F02	Ambient temperature	°F	°C
F03	Refrigerant temperature 1	°F	°C
F04	Refrigerant temperature 2	°F	°C
F10	EC Fan 1 actual speed	RPM	RPM
F11	EC Fan 1 requested speed	%	%
F12	EC Fan 1 power	kW	kW
F13	EC Fan 1 firmware version	Hex format	Hex format
F20	EC Fan 2 actual speed	RPM	RPM
F21	EC Fan 2 requested speed	%	%
F22	EC Fan 2 power	kW	kW
F23	EC Fan 2 firmware version	Hex format	Hex format
F30	EC Fan 3 actual speed	RPM	RPM
F31	EC Fan 3 requested speed	%	%
F32	EC Fan 3 power	kW	kW
F33	EC Fan 3 firmware version	Hex format	Hex format
F40	EC Fan 4 actual speed	RPM	RPM
F41	EC Fan 4 requested speed	%	%
F42	EC Fan 4 power	kW	kW
F43	EC Fan 4 firmware version	Hex format	Hex format
F50	Sub-cooling 1	°F	°C
F51	Sub-cooling 2	°F	°C
F90	Firmware Version Major		
F91	Firmware Version Minor	—	1.02.004
F92	Firmware Version Build	—	

Source: 303847 Rev. 5

10.1.4 Active Alarms Menu

In the active alarms menu, A—, press ENT to enter the active alarm items, which displays all the active alarms of condenser, see **Table 10.2** on page 54, and **Table 10.3** on page 56, for descriptions of the system and EC fan alarms. When there are multiple alarms, the IDs display by order received/initiated with the most recent alarm displayed first. **Figure 10.6** on the facing page, shows the operation and structure of the active alarms menu.

Figure 10.6 Active Alarms Menu

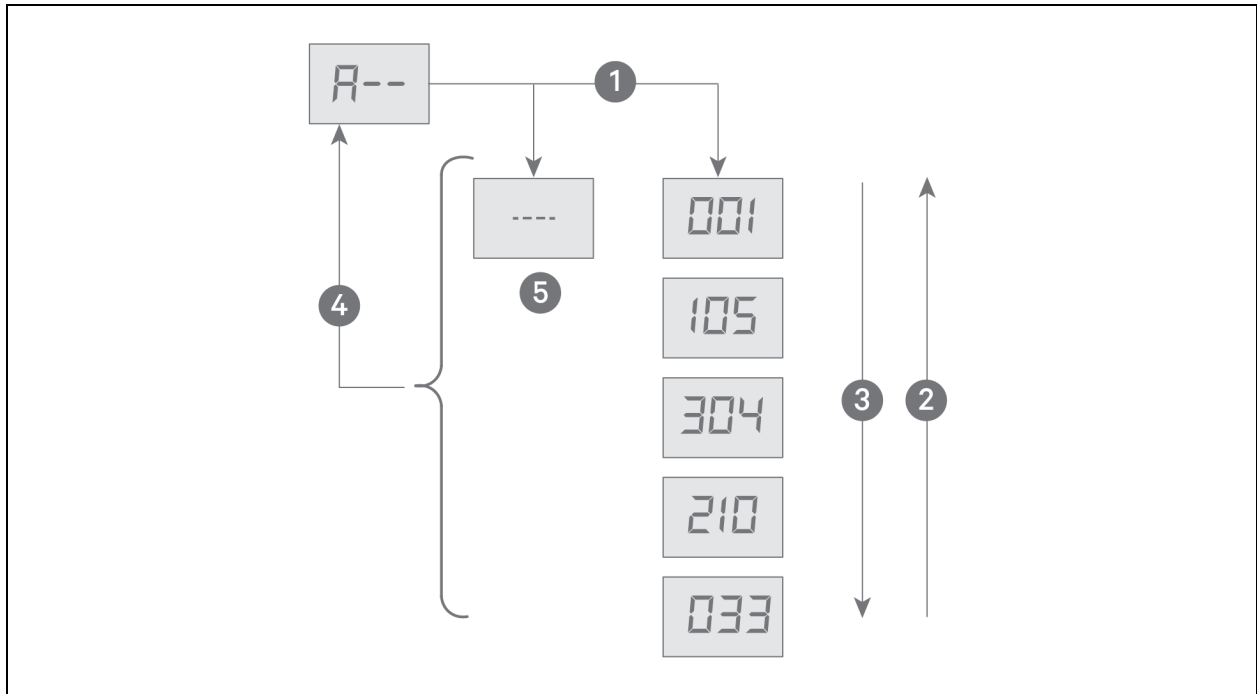

Item	Description
1	Pressing ENT displays dashes to indicate no alarm, or displays the most recent alarm ID first then in the order received/initiated. See Table 10.2 on the next page, and Table 10.3 on page 56, for a description of the alarm IDs.
2	Pressing up arrow, cycles up through the alarm IDs.
3	Pressing down arrow, cycles down through the alarm IDs.
4	Pressing ESC returns to the active alarms menu.
5	Dashes only display indicates no active alarms.

10.1.5 History Alarms Menu

In the history alarms menu, H—, press ENT to enter the history alarm items, which displays 100 history alarm records of the condenser, see **Table 10.2** on the next page, and **Table 10.3** on page 56, for descriptions of the system and EC fan alarms. The item ID is the sequence number of the history alarms. The item ID and alarm information ID display alternately. When there are no alarms, dashes "—" display. You can clear the alarm history using the C98 configuration menu item. **Figure 10.7** on the next page, shows the operation and items structure.

Figure 10.7 History Alarms Menu

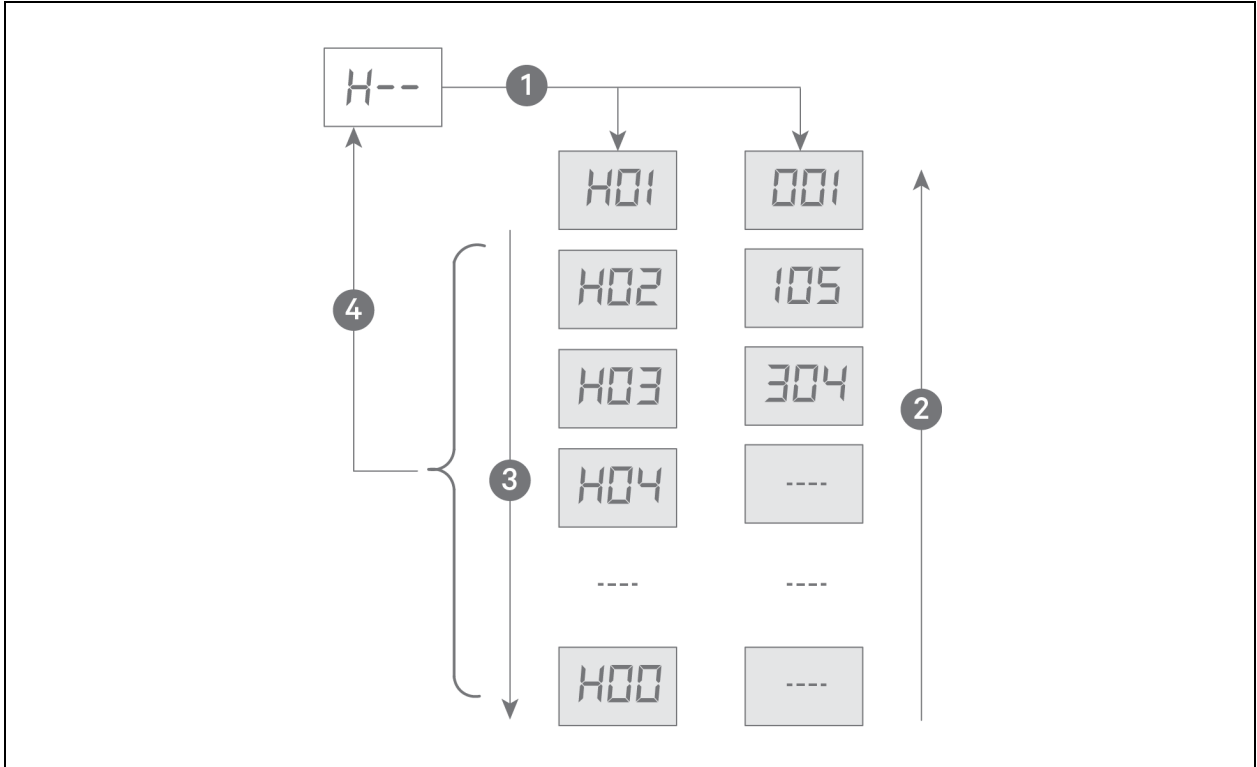

Item	Description
1	Pressing ENT displays the history alarm item(s), which alternately displays the sequence number and the alarm ID.
2	Pressing up arrow, cycles up through the sequence numbers.
3	Pressing down arrow, cycles down through the sequence numbers.
4	Pressing ESC returns to the history alarms menu.

Table 10.2 System Alarm Information

Alarm ID	Meaning	Possible Cause	Handling Method
000	CAN communication failure	Communication circuit missing or damaged.	Check communication circuit. Ignore alarm on condensers without CAN connections.
001	Ethernet communication failure	Ethernet hardware or connection failure	Ignore alarm, Ethernet connection is not present.
002	USB communication failure	USB device or file is damaged.	Replace USB device or file.
003	Data corruption	Memory chip is damaged.	Replace PCB board.
004	System error	Internal error	Reboot. If reboot fails, consult factory.
005	Remote shutdown	1. Remote shutdown signal is available.	For Cause 1, check the remote shutdown signal.

Table 10.2 System Alarm Information (continued)

Alarm ID	Meaning	Possible Cause	Handling Method
		2. TB38 is not connected.	For Cause 2, connect TB38.
006	Shutdown due to EC Fan alarm.	All fans have failed.	Consult factory.
007	SPD alarm	SPD damaged	Replace SPD.
008	Condenser pressure Sensor 2 failure	Condenser pressure Sensor 1 damaged	Replace condenser pressure Sensor 1.
009	Condenser pressure Sensor 2 failure	Condenser pressure Sensor 2 damaged	Replace condenser pressure Sensor 2
010	Condenser pressure 1 high alarm	High pressure: Fan failure, clogged coils. Low pressure: Loss of charge	High pressure alarms: Fix fan and clean coil. Low pressure alarms: Check for refrigerant leak.
011	Condenser pressure 2 high alarm		
012	Condenser pressure 1 low alarm		
013	Condenser pressure 2 low alarm		
014	EC Fan speed mode maximum must be overridden due to condenser pressure 1 high.	Condenser pressure 1 high	No action is needed.
015	EC Fan speed mode maximum must be overridden due to condenser pressure 2 high.	Condenser pressure 2 high	No action is needed.
016	Ambient temperature sensor failure	Ambient temperature sensor damaged	Replace ambient temperature sensor .
017	Ambient temperature high alarm	Ambient temperature high	No action is needed.
018	Ambient temperature low alarm	Ambient temperature low	No action is needed.
019	Condenser temperature Sensor 2 failure	Condenser temperature Sensor 2 damaged	Replace condenser temperature Sensor 1.
020	Condenser temperature Sensor 2 failure	Condenser temperature Sensor 2 damaged	Replace condenser temperature Sensor 2.
021	Condenser temperature 1 high alarm	High temperature: Fan failure, clogged coils. Low temperature: Consult factory	High temperature alarms: Fix fan and clean coils. Low temperature alarms: consult factory.
022	Condenser temperature 2 high alarm		
023	Condenser temperature 1 low alarm		
024	Condenser temperature 2 low alarm		
025	EC Fan speed mode maximum must be overridden due to refrigerant temperature 1 high	Refrigerant temperature 1 high	No action is needed.
026	EC Fan speed mode maximum must be overridden due to refrigerant temperature 2 high	Refrigerant temperature 2 high	No action is needed.

NOTE: In **Table 10.3** on the next page, (1-4) indicates the EC fan addresses. For example, (1-4) 00 means 100 for EC Fan 1, 200 for EC Fan 2, 300 for EC Fan 3, and 400 for EC Fan 4.

Table 10.3 EC Fan Alarm Information

Alarm ID	Meaning	Possible Cause	Handling Method
(1-4) 00	EC fan high link current	1. EC fan is locked. 2. EC fan is damaged.	For cause 1, check if EC Fan is locked.. For cause 2, replace EC Fan.
(1-4) 01	EC fan drive error	EC fan is damaged.	Replace EC Fan.
(1-4) 02	EC fan earth to ground fault	EC fan is damaged.	Replace EC Fan.
(1-4) 03	EC fan electronics heat sink thermal overload	1. EC fan is locked. 2. EC fan is damaged. 3. Ambient temperature is too high.	For cause 1, check if EC fan is locked. For cause 2, replace EC fan. For cause 3, check ambient temperature.
(1-4) 04	EC fan hall failure	EC fan is damaged.	Replace EC fan.
(1-4) 05	EC fan IGBT failure	EC fan is damaged.	Replace EC fan.
(1-4) 06	EC fan line fault	Power supply abnormal	Check power supply
(1-4) 07	EC fan motor locked	Motor is locked.	Check if EC fan is locked.
(1-4) 08	EC fan motor thermal overload	1. EC fan is locked. 2. EC fan is damaged. 3. Ambient temperature is too high.	For cause 1, check if EC fan is locked. For cause 2, replace EC fan. For cause 3, check ambient temperature.
(1-4) 09	EC fan phase failure alarm	Phase failure	Check power supply.
(1-4) 10	EC fan specific uncategorized alarm detected	Internal EC fan issue	Re-boot condenser if fans not running. If alarm persists and fans not running, replace fan.
(1-4) 11	EC fan specific uncategorized warning detected		
(1-4) 12	EC fan electronics high temperature condition.	1. EC Fan is locked. 2. EC Fan is damaged. 3. Ambient temperature is too high	For cause 1, check if EC fan is locked.. For cause 2, replace EC fan. For cause 3, check ambient temperature.
(1-4) 13	EC fan high link voltage	1. EC fan input power supply high voltage 2. EC fan is damaged.	For cause 1, measure power supply voltage and check if the voltage is normal.
(1-4) 14	EC fan low link voltage	1. EC Fan input power supply low voltage 2. EC Fan detection error	For cause 2, replace EC fan.
(1-4) 15	EC fan 485 communication failure	1. Communication between EC fan and PCB board failure 2. EC fan 485 communication failure 3. Board has problems. 4. EC fan not receiving power	For cause 1, check EC fan communication circuit. For cause 2, replace EC fan. For cause 3, replace PCB board. For cause 4, check fan model is not set for "0", check that the contactor for the particular fan is energized, and check fan fuses.

11 Maintenance



WARNING! Arc flash and electric shock hazard. Open all local and remote electric power supply disconnect switches, verify with a voltmeter that power is Off and wear appropriate, OSHA approved personal protective equipment (PPE) per NFPA 70E before working within the electric control enclosure. Failure to comply can cause serious injury or death. Customer must provide earth ground to unit, per NEC, CEC and local codes, as applicable. Before proceeding with installation, read all instructions, verify that all the parts are included and check the nameplate to be sure the voltage matches available utility power. The Vertiv™ Liebert® iCOM™ controller does not isolate power from the unit, even in the “Unit Off” mode. Some internal components require and receive power even during the “Unit Off” mode of the Liebert® iCOM™ controller. The factory supplied disconnect switch is inside the unit. The line side of this switch contains live high voltage. The only way to ensure that there is NO voltage inside the unit is to install and open a remote disconnect switch. Refer to unit electrical schematic. Follow all local codes.



WARNING! Risk of electric shock. Can cause equipment damage, injury or death. Open all local and remote electric power supply disconnect switches and verify with a voltmeter that power is off before working within any electric connection enclosures. Service and maintenance work must be performed only by properly trained and qualified personnel and in accordance with applicable regulations and manufacturers’ specifications. Opening or removing the covers to any equipment may expose personnel to lethal voltages within the unit even when it is apparently not operating and the input wiring is disconnected from the electrical source.



WARNING! Risk of electric shock. Can cause serious injury or death. The Liebert® iCOM™ microprocessor does not isolate power from the unit, even in the "Unit Off" mode. Some internal components require and receive power even during the "unit off" mode of the Liebert® iCOM™ control. Open all local and remote electric power disconnect switches and verify with a voltmeter that power is Off before working on any component of the system.



WARNING! Risk of contact with high speed rotating fan blades. Can cause serious injury or death. Open all local and remote electric power supply disconnect switches, verify with a voltmeter that power is off, and verify that all fan blades have stopped rotating before working in the unit cabinet or on the fan assembly. If control voltage is applied, the fan motor can restart without warning after a power failure. Do not operate the unit with any or all cabinet panels removed.



CAUTION: Risk of contact with sharp edges, splinters and exposed fasteners. Can cause personal injury. Only properly trained and qualified personnel wearing appropriate safety headgear, gloves, shoes and glasses should attempt to service unit.

- Good maintenance practices are essential to minimizing operation costs and maximizing product life.
- Read and follow monthly and semi-annual maintenance schedules included in this manual. These MINIMUM maintenance intervals may need to be more frequent based on site specific conditions.
- We recommend the use of trained and authorized service personnel, extended service contracts and factory specified replacement parts. Contact your Vertiv sales representative.

11.1 General Maintenance

Record the unit model number, serial number and voltage. Please record those numbers in the spaces below.

- **Model Number** _____
- **Serial Number** _____
- **Voltage/Phase/Frequency** _____

Periodic attention is necessary for continued satisfactory operation of your unit. Restricted air flow through the condenser coil, reduced air flow from non-functioning fans and low refrigerant system charge levels will reduce the operating efficiency of the unit and can result in high condensing temperatures and loss of cooling. In winter, do not permit snow to accumulate around the sides or underneath the condenser coil.

Monthly and semi-annual inspections and maintenance are recommended for proper system operation. Use copies of [Preventive Maintenance Checklist](#) on page 73, for each of these inspections.

11.2 Condenser Cleaning - Standard Coil

Keeping the outdoor condenser coils clean is an important factor in maintaining peak efficiency, reliability, and long life of the equipment. The unit will operate more efficiently with frequent cleanings. If you delay cleaning until heavy build up occurs, head pressure problems with the evaporator units can develop.

11.2.1 When to Clean the Condenser Coil

Normal conditions typically dictate cleaning twice a year, in spring and fall. On site or area conditions such as cottonwood trees, construction, etc., can increase cleaning frequency. On your standard monthly preventive maintenance schedule, we recommend a visual inspection of the coil to monitor conditions.

11.2.2 What to Use to Clean the Condenser Coil

NOTICE

Risk of improper cleaning agent selection, including non-base paint solvents. Can cause building and equipment damage and loss of refrigerant charge.

Using acid based or sodium hydroxide based cleaners can damage the drycooler coil and cause a loss of charge. This could cause equipment damage as well as damage to the surrounding structure.

Start with removing dirt, leaves, fibers, etc. with a soft brush or vacuum cleaner fitted with a soft brush attachment. Do not use a wire brush or scrape the coil with a metal vacuum hose. The best overall coil cleaner is plain water. If the coil is maintained and cleaned at regular intervals, water is sufficient to remove dirt and debris from the fins. Water pressure from a garden hose and sprayer usually works well. If a pressure washer is used, make sure that the equipment is set to a lower pressure setting and that the nozzle is set to the fan spray, not stream. Otherwise, damage to the fins could result. If a cleaner is required, we recommend using a neutral cleaner, neither acidic nor base. Acid type cleaners can damage the coil fins and surrounding areas. Many sites do not allow the use of acidic cleaners for environmental reasons.

11.2.3 Cleaning the Condenser Coil

1. Clean the area around the condenser to ensure leaves, grass, or loose debris will not be blown into the coil.
2. Turn off the electrical power to the unit using the lockout system.
3. Remove access door panels located on the left or right side of the condenser to gain access to the coil(s) that are to be cleaned.
4. Remove surface dirt with a vacuum cleaner, preferably with a brush or other soft attachment rather than a metal tube.
5. Flush the outside of the coil with water to loosen residue dirt. Allow the water to soak for 10 to 20 minutes to loosen surface residue. Rinse only with warm water (< 100°F).

NOTE: Do not use any chemicals or commercial coil cleaner to clean micro channel exchangers as this may cause corrosion.

6. Remove dirt and water with a vacuum cleaner, preferably with a brush or other soft attachment rather than a metal tube.
7. Inspect the coil to make sure that it is draining correctly.
8. Rinse the coil thoroughly again.
9. Vacuum the surface of the coil again and remove any excess dirt and water.
10. Use compressed air blown from the inside out to dry out the coil.
11. Do not impact the coil with the vacuum tube or air nozzle.
12. Repeat the above steps until the coil is completely clean.
 - a. **Do not hit the coil face or header with the hose.** This type of damage will impact the coil performance and operation.
13. Apply low pressure air to the coil face and vacuum out the residual water from the coil to speed up drying and prevent pooling.
 - a. Low pressure spray will reduce possible impact damage to the coil.
14. Close the access panel doors to the coil section.
15. Turn on the electrical power to the unit and run the system.

NOTE: Spraying the coil from the outside repeatedly can push a majority of the dirt to the inner section of the fins and continue to restrict air flow. Keep in mind you may not have the luxury of shutting the unit(s) down for an extended time. A scheduled shutdown with the operator may be in order.

11.3 Condenser Cleaning - E-coat Coil

A scheduled and documented QUARTERLY cleaning procedure is REQUIRED for all HVAC/R equipment coated with Modine coil and/or cabinet protection.

11.3.1 General Instructions: (detailed instructions to follow)

Remove surface loaded fibers – Coils Only

Surface loaded fibers or dirt should be removed prior to cleaning and/or water rinse to prevent further restriction of airflow. If unable to back wash the side of the coil opposite that of the coils entering air side, then surface loaded fibers or dirt should be removed with a vacuum cleaner. If a vacuum cleaner is not available, a soft non-metallic bristle brush may be used while brushing the fins, typically vertically for RTPF coils. Coil surfaces can be easily damaged (fin edges bent over) if the brush is applied across the fins.

NOTE: Use of a water stream, such as a garden hose, against a surface loaded coil will drive the fibers, dirt, and salts into the coil. This will make cleaning efforts more difficult. Surface loaded fibers must be completely removed prior to completing low velocity cleaning and water rinses.

Required quarterly cleaning and chloride removal of Modine coated equipment (coil and cabinet surfaces)

Quarterly cleaning is required to maintain warranty coverage and is essential to maintain the life of a Modine coated coil and cabinet. Coil and cabinet cleaning shall be part of the unit's regularly scheduled maintenance procedures.

Failure to clean a Modine coated coil or cabinet on the prescribed quarterly cycle will void the warranty and may result in reduced efficiency and durability in the environment.

A routine two-step quarterly coil cleaning is required to maintain warranty. Step one is to clean the coil with the below approved coil cleaner (see approved products listed in [Recommended Coil Cleaners](#) below . Step two is to use the approved salt/chloride remover listed in [Recommended Chloride Remover](#) below to dissolve soluble salts and revitalize the unit. It is very important when cleaning and/or rinsing not to exceed 1300°F and potable water pressure is less than 100 psig to avoid damaging the unit and coil fin edges.

For routine quarterly cabinet cleaning, first clean the cabinet using a rag or sponge with a mild dish soap such as Dawn to remove dirt and/or contaminants. Once the cabinet surfaces have been cleaned, a thorough rinse should be completed. After the cabinet has been cleaned, use the approved chloride remover listed in [Recommended Chloride Remover](#) below to remove soluble salts and revitalize the units cabinetry. This is then followed by a thorough water rinse. It is very important when cleaning and/or rinsing not to exceed 1300°F and potable water pressure is less than 100 psig to avoid damaging the unit.

Recommended Coil Cleaners

The following coil cleaners, assuming it is used in accordance with the manufacturer's directions on the container for proper mixing and cleaning, have been approved for use on Modine coated coils to remove mold, mildew, dust, soot, greasy residue, lint, and other particulate. Never use any cleaners that are not approved.

Table 11.1 Step 1 of 2

Coil Cleaner
GulfCoat Coil Cleaner

Recommended Chloride Remover

The following chloride remover, assuming it is used in accordance with the manufacturer's directions on the container for proper mixing, has been approved for use on Modine coated coils and cabinets to remove chlorides/salts and sulfates. Never use any chloride removers that are not approved.

Table 11.2 Step 2 of 2

Chloride Remover
CHLOR*RID Concentrate

Harsh Chemical and Acid Cleaners

Harsh chemicals, household bleach or acid cleaners should not be used to clean outdoor or indoor Modine coated coils and/or cabinets. These cleaners can be very difficult to rinse out of the coil and can accelerate the corrosion attack of the coil.

High Velocity Water or Compressed Air

High velocity water from a pressure washer or compressed air should only be used at a very low pressure, (< 100 psi), to prevent fin and/or coil damages. The force of the water or air jet may bend the fin edges and increase air side pressure drop. Reduced unit performance or nuisance unit shutdowns may occur.

11.3.2 Detailed Instructions

Scope

The Warranty Protection plan consists of a two-step process. Step 1 is to clean the coils and step 2 is to remove the salts/chlorides.

The coils are to be thoroughly cleaned using an approved coil cleaner as listed above in **Table 11.1** on the previous page. Once cleaned, they will then need to have the chlorides/salts removed by using preferred chloride remover as listed in **Table 11.2** on the previous page.

Warranty Protection Step 1 of 2

Complete the coil cleaning following these steps.

1. Ensure that the power to the unit is off and locked out.
2. Clean the area around the unit, if needed, to ensure leaves, grass or loose debris will not be blown into the coil.
3. Remove panels or tops as required to gain access to the coil(s) to be cleaned.
4. Using a pump up sprayer, fill to the appropriate level with potable water and add the correct amount of approved cleaner as per manufacture instructions leaving room for the pump plunger to be reinserted.

NOTE: Coils should always be cleaned/back flushed, opposite of airflow to prevent impacting the dirt into the coil.

5. If the coils have heavy dirt, fibers, grass, leaves, etc. on the interior or exterior face areas, a vacuum and brush should be used to remove those surface contaminants prior to applying cleaner. The interior floor, drain tray or pan areas should also be vacuumed.
6. Apply the mixed cleaner to coil surfaces using a pressurized pump up sprayer maintaining a good rate of pressure and at a medium size nozzle spray, (not a solid stream and not a wide fan but somewhere in the middle). Work in sections/panels ensuring that all areas are covered and kept wetted.
7. Apply the cleaner to unit interior air exiting side coil surfaces first. Work in sections/panels moving side to side and from top to bottom.
8. Generously soak coils by spraying cleaner directly on and into the fin pack section to be cleaned and allow the cleaning solution to soak for 5 to 10 minutes.
9. Using pressurized potable water, (< 100 psi), rinse the coils and continue to always work in sections/panels. Start at the top of the coil and slowly move vertically downward to the bottom. Then, staying in the same vertical area, slowly move back up to the top where you started. Now move over slightly overlapping the area just completed and repeat above. Continue until all coil areas on the inside of the unit have been rinsed.
10. Complete steps 5 - 9 for the exterior air entering side of the coils.
11. Final rinse – Now complete a quick rinse of both sides of the coil including the headers, piping, u-bends and hairpins.
12. If the coil has a drain pan or unit floor that is holding rinse water or cleaner, extra time and attention will need to be taken in those areas to ensure a proper rinse has been completed.

Warranty Protection Step 2 of 2

Complete the coil chloride (salt) removal following these steps.

1. CHLOR*RID is a concentrate to be used for both normal inland applications at a 100:1 mix ratio OR for severe coastal applications 50:1 mix ratio with potable water, (2.56 ounces of Chlor*rid to 1 gallon of water). Using a pump up sprayer, fill to the appropriate level with potable water and add the correct amount of CHLOR*RID salt remover leaving room for the pump plunger to be reinserted.
2. Apply Chlor*rid to all external coil surfaces using a pressurized pump up sprayer, maintaining a good rate of pressure, and at a medium size nozzle spray, (not a solid stream and not a wide fan but somewhere in the middle). Work in sections/panels ensuring that all areas are covered and kept wetted.
3. Generously soak coils by spraying Chlor*rid directly on and into the fin pack section. Let stand for 5 to 10 minutes keeping the area wetted. Do not allow to dry before rinsing.
4. Using pressurized potable water, (< 100 psi), rinse the Chlor*rid and dissolved chlorides/salts off of the coils continuing to always work in sections/panels.
5. Starting at the top of the coil, begin rinsing the coil from side to side until you reach the bottom. Repeat as many times as is necessary to ensure all coil sections/panels have been completed and are thoroughly rinsed.
6. Reinstall all panels and tops that were removed.

Complete the cabinet cleaning and chloride removal following these steps.

1. Ensure that the power to the unit is off and locked out.
2. Clean the cabinet using a rag or sponge with a mild dish soap such as Dawn to remove dirt and/or contaminants.
3. Once the cabinet surfaces have been cleaned, a thorough rinse should be completed.
4. After the cabinet has been cleaned, use the approved chloride remover listed in [Recommended Chloride Remover](#) on page 60 to remove soluble salts and revitalize the unit's cabinetry.

NOTE: It is very important when cleaning and/or rinsing not to exceed 1300°F and potable water pressure is less than 100 psig to avoid damaging the unit.

5. Final rinse – Now complete a quick rinse of all cabinetry and coils to ensure a proper final rinse.
6. Notify the proper personnel that the equipment may now be turned backed on.

11.4 Replacing the Condenser Fan



WARNING! Arc flash and electric shock hazard. Open all local and remote electric power supply disconnect switches, verify with a voltmeter that power is Off and wear appropriate, OSHA approved personal protective equipment (PPE) per NFPA 70E before working within the electric control enclosure. Failure to comply can cause serious injury or death. Customer must provide earth ground to unit, per NEC, CEC and local codes, as applicable. Before proceeding with installation, read all instructions, verify that all the parts are included and check the nameplate to be sure the voltage matches available utility power. The Vertiv™ Liebert® iCOM™ controller does not isolate power from the unit, even in the “Unit Off” mode. Some internal components require and receive power even during the “Unit Off” mode of the Liebert® iCOM™ controller. The factory supplied disconnect switch is inside the unit. The line side of this switch contains live high voltage. The only way to ensure that there is NO voltage inside the unit is to install and open a remote disconnect switch. Refer to unit electrical schematic. Follow all local codes.



WARNING! Risk of electric shock. Can cause serious injury or death. Open all local and remote electric power supply disconnect switches and verify with a voltmeter that power is off before working within the fan motor electric connection enclosures. Fan motor controls can maintain an electric charge for 10 minutes after power is disconnected. Wait 10 minutes after power is verified as off before working within the fan electric control/connection enclosures. Use only fully trained and qualified HVAC technicians to perform maintenance on the fans.



WARNING! Risk of contact with high speed rotating fan blades. Can cause serious injury or death. Open all local and remote electric power supply disconnect switches, verify with a voltmeter that power is off, and verify that all fan blades have stopped rotating before working in the unit cabinet or on the fan assembly. If control voltage is applied, the fan motor can restart without warning after a power failure. Do not operate the unit with any or all cabinet panels removed.



CAUTION: Risk of contact with hot surfaces. Can cause injury. The electronics housing, humidifier components, compressor, refrigerant discharge lines, fan motor, and some electrical components are extremely hot during unit operation. Allow sufficient time for them to cool to a touch safe temperature before working within the unit cabinet. Use extreme caution and wear appropriate, OSHA approved PPE when working on or near hot components.



CAUTION: Risk of improper moving, lifting and handling. Can cause equipment damage or injury. Only properly trained and qualified personnel should work on this equipment. Condenser fan modules for MCL models weigh in excess of 92 lb (40.8 kg) each and fan modules for MCS and MCM models weigh in excess of 40 lb (18.1 kg) each. Use proper lifting techniques and wear appropriate, OSHA approved PPE to avoid injury and dropping the fan module during removal. Equipment used in handling/lifting, and/or installing the fan assembly must meet OSHA requirements. Use handling/lifting equipment rated for the weight of the fan assembly. Use ladders rated for the weight of the fan assembly and technicians if used during installation. Refer to handling/lifting, and/or installation equipment operating manual for manufacturer's safety requirements and operating procedures.

NOTE: If at any time a parameter is entered and the condenser display does not show 888 or if the display shows Err, re-enter the parameter. If the display still shows Err after ENT is pressed, power cycle the control board by unplugging P24, waiting 15 seconds and plugging P24 back in. Contact the factory if the parameter still displays Err after ENT is pressed.

11.4.1 Fan Replacement

1. Turn Off power to the unit using the disconnect.
2. Use a voltmeter to verify that voltage is no longer present at the unit. Wait a minimum of 10 minutes to allow the EC fan capacitors to discharge before proceeding.
3. Remove the fan cover, disconnect electrical connections internal to the EC fan and remove the cable glands from the EC fan to be replaced.
4. Remove hardware that attaches the EC fan to the condenser.
5. Use lifting equipment or an adequate number of personnel to remove the EC fan from the condenser.

NOTE: A spreader bar may be required for the lifting equipment if only one technician is performing the fan replacement.

6. Install a spreader bar over the new EC fan if only one technician is performing the fan replacement.
7. Verify that the wire harness on the new EC fan is secured out of the way before lifting the fan.
8. Verify that the lifting cable/chains are not in contact with fan blades before lifting the new fan into place on the condenser.
9. Install the new fan in the condenser and connect the mounting hardware.
10. Verify that the fan blades rotate freely when installed in unit.
11. Install the new cable glands included with the new EC fan. Torque for the cable glands is:
 - 630 mm and 710 mm fans: 19.5 to 24.75 in-lb (2.2 to 2.8 Nm)
 - 800 mm fans: 32.75 to 38 in-lb (3.7 to 4.3Nm)

Dispose of the old cable glands once the new glands are installed.

12. Add a compression nut to the wire—Do not tighten the nut.
13. Reconnect the wiring to the proper terminals. See **11.4** on the previous page and **11.4** on the previous page for wiring details.
 - The torque for the electrical terminals is 11.5 in-lb (1.3 Nm). Tighten the compression nut to a torque of 22 in-lb (2.5 Nm).
14. With the PCB powered, the board display should read *FOO*. Refer to **Figure 10.1** on page 48 and **Figure 10.2** on page 48.
15. Press the **ESC** button.
16. Press the **UP** arrow button once:
 - If *P-* is displayed, see [P--Menu Programming](#) on the facing page.
 - if *P-* is not displayed, see [Manual Fan Addressing \(No P-- Menu\)](#) on the facing page
 - Once setup is complete, see [Verifying the Fan Address](#) on page 67.

NOTE: The complete list of P--, C--, and F-- parameters is located inside the lid of the electrical box panel.

11.4.2 P--Menu Programming

1. If *P-* is displayed, press the **ENT** button to enter the *P-* Menu.

The *P-* Menu allows compact setup/preparation of the condenser in the factory or in the field. Use the functions described in **Table 11.3** below, to establish a default control configuration for the board.

Table 11.3 P-- Menu Items and Definitions

Item ID	Meaning	Default	Notes
P01	Enter Preparation Mode	0	Setting this value to '1' enables preparation mode. All other P--menu items are disabled until this value is 1. Note that control operations may be affected during preparation mode, therefore the cooling unit should be off. Setting this value back to 0 creates new default values based upon selections in this menu. After default values are established, the board exits preparation mode and reboots.
P02	Automatic VSD Configuration	1	This item should only be used to address the VSDs for the unit. The value entered indicates the model of the VSD: 1 – EBM 2 – Ziehl-Abegg 3 – Fans Tech 4 – Rosenberg 6 – Multi-wing All fans must be the same model to use this parameter. When <i>ENT</i> is pressed, the board will operate and power contactors for the VSDs and assign ModBus addresses. This procedure may take up to five minutes to complete.
P03	Refrigerant Type	2	1 = R22 2 = R407C 3 = R410A
P04	Number of Circuits	1	1 = Single Circuit 2 = Dual Circuit
P05	Liebert® Lee-Temp Option	0	0 = No Liebert® Lee-Temp installed 1 = Liebert® Lee-Temp installed
P06	Condenser	1	0 = Small

NOTE: Once setup is complete, see [Verifying the Fan Address](#) on page 67.

11.4.3 Manual Fan Addressing (No P-- Menu)

1. Unplug all fans before making changes to the fan configuration menu. If a fan has been replaced or is being readdressed, keep it unplugged until the fan type has been configured and it is ready to be addressed (Step 15).
2. Turn the power On.
3. The control board flashes *FOO* on the display when it has completed its boot cycle.
4. Press the **ESC** button.
5. Use the **UP** or **DOWN** arrow button until *C--* displays.
6. Press the **ENT** button.
7. Use the **UP** or **DOWN** arrow button until *CO3* displays.
8. Press the **ENT** button.

- Use the **UP** or **DOWN** arrow button to select one of five options:

Table 11.4 Configuration Code Values

Configuration Code	Fan #	Value
C03	Fan 1	0 = No Fan
C04	Fan 2	1 = EBM Papst 2 = Ziehl-Abegg
C05	Fan 3	4 = Rosenberg
C06	Fan 4	6 = Multi-wing

- Press the **ENT** button.
- If the new value is entered into the control board, the display flashes "888."
- Press the **ESC** button to display C03.
- Repeat steps 4 through 11 for C04, C05 and C06 setting them to 0, No Fan.
- Unplug the power connector to the Condenser controller board (P24).
- Reconnect only the fan to be addressed, to P23 (on the control board), Fan 1's connection. Make sure to only plug in one fan at a time during this process or you may corrupt the settings in the other fans. Plugs listed below:
 - P23 = Fan 1
 - P27 = Fan 2
 - P28 = Fan 3
 - P29 = Fan 4
- Wait 30 seconds (60 seconds when using Multi-wing).
- Power the condenser board back up and wait for the F00 to be displayed.
- Use the **UP** or **DOWN** arrow button to select one of the following parameters.

The correct parameter depends on the supplier of the fan that will be addressed.

 - C00—EBM Papst fan
 - C01—Ziehl-Abegg fan
 - C29 = Rosenberg fan
 - C30 = Multi-wing
- Press the **ENT** button.
- Use the **UP** or **DOWN** arrow button to the correct fan address number. Fan 1 should be 1 (fan closest to electric panel end). Fan 2 should be 2, etc.
- Press the **ENT** button. The display flashes "888 " when the command is accepted.
- Press the **ESC** button for the parameter to be shown on the display.
- Repeat steps 7 through 22 for the rest of the fans that need to be addressed such that only the fan to be addressed is connected and it is plugged into the fan 1 output P23.
- Once addressing is complete, unplug all fans so they can be connected to the correct output after configuration (Step 28).
- Use the C3-C6 commands as shown in Step 9 so all installed fans are set to the correct matching brand.
- Unplug the power plug, P24, from the control board.
- Wait 30 seconds.

28. Plug all the contactor output plugs back into the board in their correct positions.
29. Plug P24 back into the control board.
30. After the control board completes its boot cycle and all the contactors are energized, wait five seconds.
31. Press the **ESC** button.
32. Use the **UP** or **DOWN** arrow button until A-- is on the display.
33. Press **ENT** button.
34. Use the **UP** or **DOWN** arrow button to see if any of the following errors are shown.
 - a. 115: Unable to communicate with Fan 1.
 - b. 215: Unable to communicate with Fan 2.
 - c. 315: Unable to communicate with Fan 3.
 - d. 415: Unable to communicate with Fan 4.
35. If any of these errors appear, check the communication wiring at the problem fan and the fan before it.
36. If the wiring is correct and properly wired to the terminal, repeat the fan addressing procedure in steps 14 through 34.
37. If none of the errors listed in step 34 displays, press the **ESC** button.

11.4.4 Verifying the Fan Address

To verify that each fan has a unique address:

1. Use the **UP** or **DOWN** arrow button until C-- displays.
2. Press the **ENT** button.
3. In the Manual/System Control Selection parameter use the **UP** or **DOWN** arrow button until C24 displays.
4. In the Manual Control configuration parameter, press the **ENT** button.
5. Use the **UP** or **DOWN** arrow button to select 0.
6. Press the **ENT** button. The display reads 888 if the command is accepted.
7. Press the **ESC** button to display C24.
8. Use the **UP** or **DOWN** arrow button until C34 displays.
9. Press **ENT** button. If Fan 1 is running, the fans speed should display in terms of percentage of full speed. If Fan 1 is not running, 0.00 should display.
10. Use the **UP** or **DOWN** arrow button to enter 100% speed.
11. Press the **ENT** button. The display reads "888" if the command is accepted.
 - Fan 1 should speed up to 100%, and all the other fans should stay the same speed.
12. If Fan 1 is not running or if any of the other fans also speed up to 100%, steps 14 through 22 of [Replacing the Condenser Fan](#) on page 63, must be repeated.
13. Press the **ESC** button for the parameter to be shown on the display.
14. Repeat steps 3 through 8 for the rest of the fans, if present.
 - C35: for Fan 2.
 - C36: for Fan 3.
 - C37: for Fan 4.

NOTE: All fans should be at 100% speed.

15. Use the **UP** or **DOWN** arrow button until C24 displays.

16. Press the **ENT** button.
17. In the System Control configuration parameter, use the **UP** or **DOWN** arrow button to select *1*.
18. Press the **ENT** button. The display flashes "888" if the command is accepted.
19. Press the **ESC** button to display *C24*. All fans should return to a normal speed based on the pressure input and the state of indoor unit's compressor.

11.5 Replacing the Premium Efficiency Control Board

Use these steps to replace the premium efficiency control board in the condenser.



WARNING! Arc flash and electric shock hazard. Open all local and remote electric power supply disconnect switches, verify with a voltmeter that power is Off and wear appropriate, OSHA approved personal protective equipment (PPE) per NFPA 70E before working within the electric control enclosure. Failure to comply can cause serious injury or death. Customer must provide earth ground to unit, per NEC, CEC and local codes, as applicable. Before proceeding with installation, read all instructions, verify that all the parts are included and check the nameplate to be sure the voltage matches available utility power. The Vertiv™ Liebert® iCOM™ controller does not isolate power from the unit, even in the “Unit Off” mode. Some internal components require and receive power even during the “Unit Off” mode of the Liebert® iCOM™ controller. The factory supplied disconnect switch is inside the unit. The line side of this switch contains live high voltage. The only way to ensure that there is NO voltage inside the unit is to install and open a remote disconnect switch. Refer to unit electrical schematic. Follow all local codes.

11.5.1 Preparing to Replace the Board

1. Verify that the following jumpers are installed on the new board (see **Figure 11.1** on the next page):
 - Jumper at J4 and J6 on Pins 2 and 3.
 - Jumper on J2.
 - Jumper on J5 on Pins 1 and 2.
2. Locate the latest revision of the HMI parameters label, 30384-7P1, included with the new control board.

NOTE: In **Figure 11.1** on the next page, J6 is the CANbus termination jumper. J4 is the RS485 service termination jumper. If the condenser is the last device in the CANbus communication line, the jumper must be placed between Pins 1 and 2 of J6. If the condenser is not the last device in the CANbus communication line, the jumpers on J6 must be placed on Pins 2 and 3. If the jumper is not in the correct positions, CANbus communication errors may occur. The jumper on J4 will always be placed between Pins 1 and 2.

NOTE: In **Figure 11.1** on the next page, a jumper must be present at J2. If a jumper is not present, the control board will not boot properly during power start-up.

Figure 11.1 Jumper Locations on Control Board

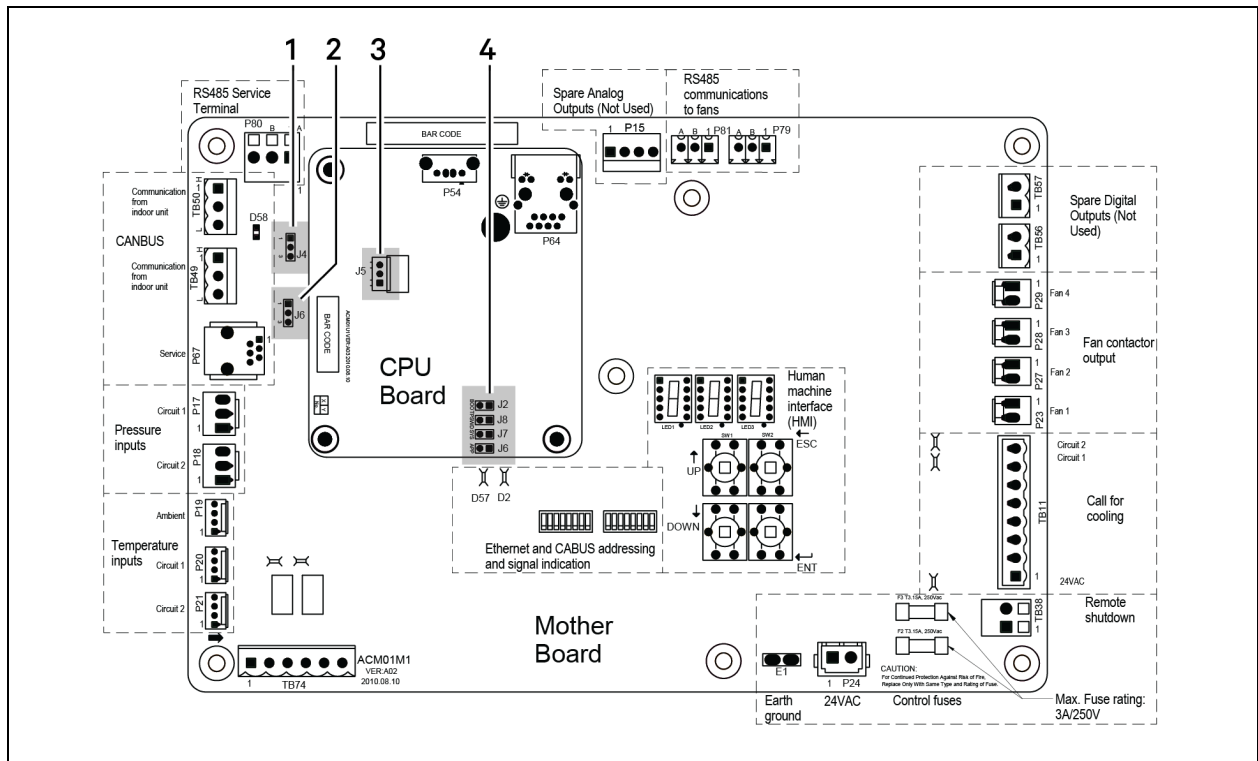

Item	Description
1	J4, RS485 service termination jumper
2	J6, Canbus termination jumper
3	J5
4	J2

11.5.2 Installing the Replacement Board



WARNING! Arc flash and electric shock hazard. Open all local and remote electric power supply disconnect switches, verify with a voltmeter that power is Off and wear appropriate, OSHA approved personal protective equipment (PPE) per NFPA 70E before working within the electric control enclosure. Failure to comply can cause serious injury or death. Customer must provide earth ground to unit, per NEC, CEC and local codes, as applicable. Before proceeding with installation, read all instructions, verify that all the parts are included and check the nameplate to be sure the voltage matches available utility power. The Vertiv™ Liebert® iCOM™ controller does not isolate power from the unit, even in the “Unit Off” mode. Some internal components require and receive power even during the “Unit Off” mode of the Liebert® iCOM™ controller. The factory supplied disconnect switch is inside the unit. The line side of this switch contains live high voltage. The only way to ensure that there is NO voltage inside the unit is to install and open a remote disconnect switch. Refer to unit electrical schematic. Follow all local codes.

1. Turn Off the disconnect switch on the condenser enclosure cover.
2. Open the control enclosure cover.
3. Manually turn On the disconnect switch.

NOTE: Power is On and a shock hazard exists with exposure to hazardous voltage components.

4. If the board can still be powered up and has a display, record the parameter settings.
To obtain parameters go to the C-- menu and press the **UP** or **DOWN** arrow button to read and record the values for C03-09 and C27.
5. Record all of the DIP switch positions for the CANbus DIP switch package. Retain these for setting up the new board.
6. Record the positions of the jumpers for J2, J4, J5 and J6 on control board in the unit. Retain these for setting up the new board.
7. Disconnect power from the condenser by turning Off the main disconnect switch.
8. Use a voltmeter to verify that voltage is no longer present in the unit.
9. Remove the plugs and field installed wires from the old board. Note the polarity for the CANbus wiring going to P49 and P50, if present.
10. Mark wires P49-1, P49-3, etc, if they are not already marked.
11. Remove the mechanical fasteners holding the control board in place and remove the old control board.
12. Install the new control board using the fasteners removed in step 11.
13. Reattach the plugs. Refer to the hot stamps on the wire harnesses that correspond to the correct plug on the board. Verify that the plugs are installed properly.
14. Change the CANbus DIP switch positions so they match the control board that was removed. If the condenser is the second condenser on the CANbus communication line, set Position 1 of the CANbus DIP switch from On to Off.
15. Change the jumper positions for J2, J4, J5 and J6 to match the control board that was removed. If the condenser is the last device on the CANbus communication line, move the jumper at J6 from Pins 2 and 3 to Pins 1 and 2 (see **Figure 11.1** on the previous page).
16. Power up the unit.

17. Change the parameters to match the parameters from the control board that was removed if they were obtained from the old board in step 4 . See step 18 if the parameters were unavailable.
18. If the old board parameters were unavailable, use the new HMI label included in kit to obtain the proper settings. Parameters C03, C04, C05 and C06 must be programmed with the proper EC fan supplier used on the unit.
19. Address the fans (refer to [Replacing the Condenser Fan](#) on page 63).
20. Compare the HMI label on the unit with the latest revision.

If there are differences, clean and dry the surface of the old HMI label; attach the new label on top of the old label, covering the old label with the new one.

21. Verify that the control board is reading pressure and temperature.
22. Verify that there are no communication alarms with the fans or with the cooling unit the condenser is serving.
23. Verify proper fan operation by adjusting the cooling unit that this condenser serves so that it calls for cooling.

12 Preventive Maintenance Checklist

Source: DPN003119, Rev 1

Inspection Date	Job Name	
Indoor Unit Model #	Indoor Unit Serial Number #	
Condensing Unit Model #	Condensing Unit Serial #	
Room Temperature/Humidity	° %	Ambient Temperature °

Not all units will have all components. To determine your unit's configuration, compare the indoor unit model number above and the information in the Components and Nomenclature section.

Good maintenance practices are essential to minimizing operation cost and maximizing product life. Read and follow all applicable maintenance checks listed below. At a minimum, these checks should be performed semi-annually. However, maintenance intervals may need to be more frequent based on site specific conditions. Review the unit user manual for further information on unit operation. We recommend the use of trained and authorized service personnel, extended service contracts, and factory certified replacement parts. Contact your local sales representative for more details.

Check all that apply:

1. Check coil clean and free of debris .
2. Check fans free of debris.
3. Fans securely mounted
4. Verify motor bearings in good condition.
5. Check all refrigerant lines for vibration isolation. Support as necessary.
6. Check/re-torque wire connections.
7. Check contactors for pitting (replace if pitted).
8. Check surge protection device status indicator lights (if equipped).
9. Verify operation sequence/setpoints.
10. Check refrigerant lines for signs of leaks/repair as found.
11. Charge verification:
 - a. Outdoor Ambient Temperature _____
 - b. Sub-cooling _____
 - c. Indoor Unit Return Air Temperature _____
 - d. Sight Glass Level (if Vertiv™ Liebert® Lee-Temp or pumped refrigerant) _____
12. Check motor amp draw

#1	L1	L2	L3
#2	L1	L2	L3
#3	L1	L2	L3
#4	L1	L2	L3
#5	L1	L2	L3
#6	L1	L2	L3
#7	L1	L2	L3
#8	L1	L2	L3

Vertiv™ Liebert® EconoPhase Pumped Refrigerant Economizer

1. Check for refrigerant leaks.
2. Check/re-torque wire connections.
3. Check contactors for pitting (replace if pitted).
4. Verify pump speed control operation.
5. Check pump mounting.

Appendices

Appendix A: Technical Support and Contacts

A.1 Technical Support/Service in the United States

Vertiv Group Corporation

24x7 dispatch of technicians for all products.

1-800-543-2378

Liebert® Thermal Management Products

1-800-543-2378

Liebert® Channel Products

1-800-222-5877

Liebert® AC and DC Power Products

1-800-543-2378

A.2 Locations

United States

Vertiv Headquarters

505 N. Cleveland Ave.

Westerville, OH 43082, USA

Europe

Via Leonardo Da Vinci 8 Zona Industriale Tognana

35028 Piove Di Sacco (PD) Italy

Asia

7/F, Dah Sing Financial Centre

3108 Gloucester Road

Wanchai, Hong Kong

This page intentionally left blank

Appendix B: Sound Data Tables

Table B.1 Sound Power Data at 100% Fan Speed, A-Weighted, dBA

		Frequency Hz								
		63	125	250	500	1000	2000	4000	8000	Total
		Maximum Sound Power								
MCS	028	50	70	66	70	73	71	64	58	78
	056	53	73	69	73	76	74	67	61	81
MCM	040	49	67	73	76	78	76	69	62	82
	080	52	70	76	79	81	79	72	65	85
	160	55	73	79	82	84	82	75	68	89
MCL	055	62	71	75	80	82	80	73	66	86
	110	65	74	78	83	85	83	76	69	89
	165	67	76	79	85	87	85	78	71	91
	220	68	77	81	86	88	86	79	72	92

B.1 Sample Data, Measured, and Calculated

Sound power of source is independent of the environment or distance from the source. Given the sound power of a source, the sound pressure can be calculated for any distance or location given that detailed information is given or measured. For the case of the Vertiv™ Liebert® MC condenser setting on a flat surface outside simplifies the calculation to a free field calculation to a hemispherical radiation field at the listener or measurement distance “d”. The sound pressure for this case is calculated using the following equation.

$$L_p = L_w + 10 \cdot \log(Q/4\pi d^2) + 10.3$$

Where:

L_w = Sound power

L_p = Sound pressure

d = Distance from source (feet)

Q = Directional factor, 2 for uniform hemispherical radiation

Calculation methods used in this data are patterned after the ASHRAE Guide; other ASHRAE Publications, and the AHRI Acoustical Standards. While a very significant effort has been made to ensure the technical accuracy of this data, it is assumed that the user is knowledgeable in the art of system sound estimation and is aware of the tolerances involved in real world acoustical estimation. This data makes certain assumptions as to the dominant sound sources and sound paths which may not always be appropriate to the real system being estimated. If in doubt about the estimation of expected sound levels in a space, an Acoustical Engineer or a person with sound prediction expertise should be consulted.

B.2 Vertiv™ Liebert® MC Small Platform Sound Power Data

Table B.2 Sound Power Data for MCS028, dB

Sound Power (Measured One Fan)								
Octave Band Data					A-Weighted, dBA			
Frequency (Hz)	Percent Fan Speed				Percent Fan Speed			
	20%	50%	80%	100%	20%	50%	80%	100%
63	46 ¹	55	66	68	20 ¹	29	40	41
125	47	61	69	86	31	45	53	70
250	47	58	69	75	38	49	60	66
500	49	57	69	74	46	54	66	70
1000	45	56	68	73	45	56	68	73
2000	34	50	63	70	35	51	64	71
4000	27 ¹	43	57	63	28 ¹	44	58	64
8000	29 ¹	35	52	59	28 ¹	34	51	58
Total	54	65	76	87	49	60	72	78

¹These values indicate the upper boundary limit due to background noise levels. Actual field values may be equal to or less than that listed.

Table B.3 Sound Power Data for MCS056, dB

Sound Power (Calculated Two Fan)								
Octave Band Data					A-Weighted, dBA			
Frequency (Hz)	Percent Fan Speed				Percent Fan Speed			
	20%	50%	80%	100%	20%	50%	80%	100%
63	49 ¹	58	69	71	23 ¹	32	43	44
125	50	64	72	89	34	48	56	73
250	50	61	72	78	41	53	63	69
500	52	60	72	77	49	57	69	73
1000	48	59	71	76	48	59	71	76
2000	37	53	66	73	38	54	67	74
4000	30 ¹	46	60	66	31 ¹	47	61	67
8000	32 ¹	38	55	62	31 ¹	37	54	61
Total	57	68	79	90	52	63	75	81

¹These values indicate the upper boundary limit due to background noise levels. Actual field values may be equal to or less than that listed.

B.3 Vertiv™ Liebert® MC Small Platform Sound Pressure Data

Table B.4 Sound Pressure Data for MCS028 at 10 ft. (3.05 m), dB

Sound Pressure at Distance = 10 ft. (3.05 m), dB								
Octave Band Data					A-Weighted, dBA			
Frequency (Hz)	Percent Fan Speed				Percent Fan Speed			
	20%	50%	80%	100%	20%	50%	80%	100%
63	29 ¹	38	48	50	3 ¹	11	22	24
125	29	44	51	68	13	27	35	52
250	29	40	51	57	20	32	43	48
500	32	39	51	56	28	36	48	53
1000	27	38	51	55	27	38	51	55
2000	16	32	45	52	17	33	47	53
4000	10 ¹	25	39	46	11 ¹	26	40	47
8000	11 ¹	17	34	41	10 ¹	16	33	40
Total	37	48	58	69	32	42	54	60

¹These values indicate the upper boundary limit due to background noise levels. Actual field values may be equal to or less than that listed.

Sound pressure level data used to develop this table was determined to be in accordance with AHRI Standard 220 and 270. Source: ASHRAE Fundamentals 2009, 8.8

Table B.5 Sound Pressure Data for MCS056 at 10 ft. (3.05 m), dB

Sound Pressure at Distance = 10 ft. (3.05 m), dB								
Octave Band Data					A-Weighted, dBA			
Frequency (Hz)	Percent Fan Speed				Percent Fan Speed			
	20%	50%	80%	100%	20%	50%	80%	100%
63	32	41	51	53	6	15	25	27
125	32	47	54	71	16	30	38	55
250	32	43	54	60	23	35	46	51
500	35	42	54	59	31	39	51	56
1000	30	42	54	58	30	42	54	58
2000	19	35	48	55	20	36	50	56
4000	13	28	42	49	14	29	43	50
8000	14	20	37	44	13	19	36	43
Total	40	51	61	72	35	45	57	63

¹These values indicate the upper boundary limit due to background noise levels. Actual field values may be equal to or less than that listed.

Sound pressure level data used to develop this table was determined to be in accordance with AHRI Standard 220 and 270. Source: ASHRAE Fundamentals 2009, 8.8

B.4 Vertiv™ Liebert® MC Medium Platform Sound Power Data

Table B.6 Sound Power Data for MCM040, dB

Sound Power (Measured One Fan)								
Octave Band Data					A-Weighted, dBA			
Frequency (Hz)	Percent Fan Speed				Percent Fan Speed			
	20%	50%	80%	100%	20%	50%	80%	100%
63	52 ¹	64	77	75	26 ¹	38	51	49
125	49	68	77	83	32	52	61	67
250	46	64	76	82	38	55	67	73
500	53	61	74	79	50	58	71	76
1000	40	59	72	78	40	59	72	78
2000	31 ¹	54	68	75	32 ¹	55	69	76
4000	30 ¹	46	61	68	31 ¹	47	62	69
8000	30 ¹	39	56	63	29 ¹	38	55	62
Total	57	71	83	87	51	63	76	82

¹These values indicate the upper boundary limit due to background noise levels. Actual field values may be equal to or less than that listed.

Table B.7 Sound Power Data for MCM080, dB

Sound Power (Calculated Two Fan)								
Octave Band Data					A-Weighted, dBA			
Frequency (Hz)	Percent Fan Speed				Percent Fan Speed			
	20%	50%	80%	100%	20%	50%	80%	100%
63	55 ¹	67	80	78	29 ¹	41	54	52
125	52	71	80	86	35	55	64	70
250	49	67	79	85	41	58	70	76
500	56	64	77	82	53	61	74	79
1000	43	62	75	81	43	62	75	81
2000	34 ¹	57	71	78	35 ¹	58	72	79
4000	33 ¹	49	64	71	34 ¹	50	65	72
8000	33 ¹	42	59	66	32 ¹	41	58	65
Total	60	74	86	90	54	66	79	85

¹These values indicate the upper boundary limit due to background noise levels. Actual field values may be equal to or less than that listed.

Table B.8 Sound Power Data for MCM160, dB

Sound Power (Calculated Four Fan)								
Octave Band Data					A-Weighted, dBA			
Frequency (Hz)	Percent Fan Speed				Percent Fan Speed			
	20%	50%	80%	100%	20%	50%	80%	100%
63	58 ¹	70	83	81	32 ¹	44	57	55
125	55	74	83	89	38	58	67	73
250	52	70	82	88	44	61	73	79
500	59	67	80	85	56	64	77	82
1000	46	65	78	84	46	65	78	84
2000	37 ¹	60	74	81	38 ¹	61	75	82
4000	36 ¹	52	67	74	37 ¹	53	68	75
8000	36 ¹	45	62	69	35 ¹	44	61	68
Total	63	77	89	93	57	70	82	89

¹These values indicate the upper boundary limit due to background noise levels. Actual field values may be equal to or less than that listed.

B.5 Vertiv™ Liebert® MC Medium Platform Sound Pressure Data

Table B.9 Sound Pressure Data for MCM040 at 10 ft. (3.05 m), dB

Sound Pressure at Distance = 10 ft. (3.05 m) dB								
Octave Band Data					A-Weighted, dBA			
Frequency (Hz)	Percent Fan Speed				Percent Fan Speed			
	20%	50%	80%	100%	20%	50%	80%	100%
63	34 ¹	46	59	58	8 ¹	20	33	31
125	31	50	59	65	15	34	43	49
250	29	46	58	64	20	38	49	55
500	36	44	56	62	33	40	53	59
1000	22	41	54	60	22	41	54	60
2000	13 ¹	36	50	57	14 ¹	37	52	58
4000	13 ¹	28	44	51	14 ¹	29	45	52
8000	12 ¹	21	38	46	11 ¹	20	37	45
Total	39	54	65	70	33	46	59	65

¹These values indicate the upper boundary limit due to background noise levels. Actual field values may be equal to or less than that listed.

Sound pressure level data used to develop this table was determined to be in accordance with AHRI Standard 220 and 270. Source: ASHRAE Fundamentals 2009, 8.8

Table B.10 Sound Pressure Data for MCM080 at 10 ft. (3.05 m), dB

Sound Pressure at Distance = 10 ft. (3.05 m), dB								
Octave Band Data					A-Weighted, dBA			
Frequency (Hz)	Percent Fan Speed				Percent Fan Speed			
	20%	50%	80%	100%	20%	50%	80%	100%
63	38 ¹	49	62	61	11 ¹	23	36	34
125	34	54	62	68	18	37	46	52
250	32	49	61	67	23	41	52	58
500	39	47	59	65	36	43	56	62
1000	25	44	57	63	25	44	57	63
2000	16 ¹	39	53	60	17 ¹	40	55	61
4000	16 ¹	31	47	54	17 ¹	32	48	55
8000	15 ¹	24	41	49	14 ¹	23	40	48
Total	42	57	68	73	36	49	62	68

¹These values indicate the upper boundary limit due to background noise levels. Actual field values may be equal to or less than that listed.

Sound pressure level data used to develop this table was determined to be in accordance with AHRI Standard 220 and 270. Source: ASHRAE Fundamentals 2009, 8.8

Table B.11 Sound Pressure Data for MCM160 at 10 ft. (3.05 m), dB

Sound Pressure at Distance = 10 ft. (3.05 m) , dB								
Octave Band Data					A-Weighted, dBA			
Frequency (Hz)	Percent Fan Speed				Percent Fan Speed			
	20%	50%	80%	100%	20%	50%	80%	100%
63	41 ¹	52	65	64	14 ¹	26	39	37
125	37	57	65	71	21	40	49	55
250	35	52	64	70	26	44	55	61
500	42	50	62	68	39	46	59	65
1000	28	47	60	66	28	47	60	66
2000	19 ¹	42	56	63	20 ¹	43	58	64
4000	19 ¹	34	50	57	20 ¹	35	51	58
8000	18 ¹	27	44	52	17 ¹	26	43	51
Total	45	60	71	76	39	52	65	71

¹These values indicate the upper boundary limit due to background noise levels. Actual field values may be equal to or less than that listed.

Sound pressure level data used to develop this table was determined to be in accordance with AHRI Standard 220 and 270. Source: ASHRAE Fundamentals 2009, 8.8

B.6 Vertiv™ Liebert® MC Large Platform Sound Power Data

Table B.12 Sound Power Data for MCL055, dB

Sound Power (Measured One Fan)								
Octave Band Data					A-Weighted, dBA			
Frequency (Hz)	Percent Fan Speed				Percent Fan Speed			
	20%	50%	80%	100%	20%	50%	80%	100%
63	50	70	76	81	24	43	49	54
125	51	68	77	88	35	52	61	71
250	52	66	77	83	43	57	68	75
500	56	64	77	83	53	60	74	80
1000	39	61	75	81	39	61	75	81
2000	33	55	71	79	34	56	72	80
4000	31 ¹	49	65	72	32 ¹	50	66	73
8000	29 ¹	42	59	67	28 ¹	41	58	66
Total	59	74	84	91	54	65	79	86

¹These values indicate the upper boundary limit due to background noise levels. Actual field values may be equal to or less than that listed.

Table B.13 Sound Power Data for MCL110, dB

Sound Power (Calculated Two Fan)								
Octave Band Data					A-Weighted, dBA			
Frequency (Hz)	Percent Fan Speed				Percent Fan Speed			
	20%	50%	80%	100%	20%	50%	80%	100%
63	53	73	79	84	27	46	52	57
125	54	71	80	91	38	55	64	74
250	55	69	80	86	46	60	71	78
500	59	67	81	86	56	63	77	83
1000	42	64	78	84	42	64	78	84
2000	36	58	74	82	37	59	75	83
4000	34 ¹	52	68	75	35 ¹	53	69	76
8000	32 ¹	45	62	70	31 ¹	44	61	69
Total	62	77	87	94	57	68	82	89

¹These values indicate the upper boundary limit due to background noise levels. Actual field values may be equal to or less than that listed.

Table B.14 Sound Power Data for MCL165, dB

Sound Power (Calculated Three Fan)								
Octave Band Data					A-Weighted, dBA			
Frequency (Hz)	Percent Fan Speed				Percent Fan Speed			
	20%	50%	80%	100%	20%	50%	80%	100%
63	55	74	80	85	29	48	54	59
125	56	73	82	92	40	57	66	76
250	57	70	82	88	48	62	73	79
500	61	68	82	88	58	65	79	85
1000	44	66	80	86	44	66	80	86
2000	37	60	76	84	38	61	77	85
4000	35 ¹	54	70	77	36 ¹	55	71	78
8000	34 ¹	47	64	72	33 ¹	46	63	71
Total	64	78	89	96	59	70	84	91

¹These values indicate the upper boundary limit due to background noise levels. Actual field values may be equal to or less than that listed.

Table B.15 Sound Power Data for MCL220, dB

Sound Power (Calculated Four Fan)								
Octave Band Data					A-Weighted, dBA			
Frequency (Hz)	Percent Fan Speed				Percent Fan Speed			
	20%	50%	80%	100%	20%	50%	80%	100%
63	56	76	82	87	30	49	55	60
125	57	74	83	94	41	58	67	77
250	58	72	83	89	49	63	74	81
500	62	70	84	89	59	66	80	86
1000	45	67	81	87	45	67	81	87
2000	39	61	77	85	40	62	78	86
4000	37	55	71	78	38	56	72	79
8000	35	48	65	73	34	47	64	72
Total	65	80	90	97	60	71	85	92

¹These values indicate the upper boundary limit due to background noise levels. Actual field values may be equal to or less than that listed.

B.7 Vertiv™ Liebert® MC Large Platform Sound Pressure Data

Table B.16 Sound Pressure Data for MCL055 at 10 ft. (3.05 m), dB

Sound Pressure at Distance = 10 ft (3.05 m), dB								
Octave Band Data					A-Weighted, dBA			
Frequency (Hz)	Percent Fan Speed				Percent Fan Speed			
	20%	50%	80%	100%	20%	50%	80%	100%
63	33	52	58	63	6	26	32	37
125	34	50	59	70	17	34	43	54
250	34	48	59	66	26	39	51	57
500	39	46	60	65	35	43	57	62
1000	21	43	57	63	21	43	57	63
2000	15	37	53	61	16	38	54	63
4000	13 ¹	31	47	55	14 ¹	32	48	56
8000	12 ¹	25	42	49	11 ¹	24	41	48
Total	42	56	66	74	36	48	62	68

¹These values indicate the upper boundary limit due to background noise levels. Actual field values may be equal to or less than that listed.

Sound pressure level data used to develop this table was determined to be in accordance with AHRI Standard 220 and 270. Source: ASHRAE Fundamentals 2009, 8.8

Table B.17 Sound Pressure Data for MCL110 at 10 ft. (3.05 m), dB

Sound Pressure at Distance = 10 ft (3.05 m), dB								
Octave Band Data					A-Weighted, dBA			
Frequency (Hz)	Percent Fan Speed				Percent Fan Speed			
	20%	50%	80%	100%	20%	50%	80%	100%
63	36	55	61	66	9	29	35	40
125	37	53	62	73	21	37	46	57
250	37	51	62	69	29	42	54	60
500	42	49	63	68	38	46	60	65
1000	24	46	60	66	24	46	60	66
2000	18	40	56	64	19	42	57	66
4000	16 ¹	34	50	58	17 ¹	35	51	59
8000	15 ¹	28	45	52	14 ¹	27	44	51
Total	45	59	69	77	39	51	65	71

¹These values indicate the upper boundary limit due to background noise levels. Actual field values may be equal to or less than that listed.

Sound pressure level data used to develop this table was determined to be in accordance with AHRI Standard 220 and 270. Source: ASHRAE Fundamentals 2009, 8.8

Table B.18 Sound Pressure Data for MCL165 at 10 ft. (3.05 m), dB

Sound Pressure at Distance = 10 ft (3.05 m), dB								
Octave Band Data					A-Weighted, dBA			
Frequency (Hz)	Percent Fan Speed				Percent Fan Speed			
	20%	50%	80%	100%	20%	50%	80%	100%
63	37	57	63	68	11	30	36	41
125	38	55	64	75	22	39	48	59
250	39	53	64	70	30	44	55	62
500	43	51	65	70	40	47	61	67
1000	26	48	62	68	26	48	62	68
2000	20	42	58	66	21	43	59	67
4000	18 ¹	36	52	60	19 ¹	37	53	61
8000	16 ¹	30	47	54	15 ¹	28	45	53
Total	46	61	71	78	41	53	66	73

¹These values indicate the upper boundary limit due to background noise levels. Actual field values may be equal to or less than that listed.

Sound pressure level data used to develop this table was determined to be in accordance with AHRI Standard 220 and 270. Source: ASHRAE Fundamentals 2009, 8.8

Table B.19 Sound Pressure Data for MCL220 at 10 ft. (3.05 m), dB

Sound Pressure at Distance = 10 ft (3.05 m), dB								
Octave Band Data					A-Weighted, dBA			
Frequency (Hz)	Percent Fan Speed				Percent Fan Speed			
	20%	50%	80%	100%	20%	50%	80%	100%
63	39	58	64	69	13	32	38	43
125	40	56	65	76	24	40	49	60
250	40	54	65	72	32	45	57	63
500	45	52	66	71	41	49	63	68
1000	27	49	63	69	27	49	63	69
2000	21	43	59	67	22	45	60	69
4000	19	37	53	61	20	38	54	62
8000	18	31	48	55	17	30	47	54
Total	48	62	72	80	42	54	68	74

¹These values indicate the upper boundary limit due to background noise levels. Actual field values may be equal to or less than that listed.

Sound pressure level data used to develop this table was determined to be in accordance with AHRI Standard 220 and 270. Source: ASHRAE Fundamentals 2009, 8.8

This page intentionally left blank

Appendix C: Optional Configuration for Vertiv™ Liebert® MC Seismic Application or Wind Load Certification

Electrical wiring, conduit, and/or other connections to the equipment is the responsibility of others. Data and recommendations are supplied in the [Submittal Drawings](#) on page 91 , and in the unit installation supplement for seismic or wind load installation.

The following table lists the relevant documents by number and title.

Table C.1 Seismic Application Drawings

Document Number	Title
DPN002414	Seismic Anchorage Data One Fan Models

Table C.2 Wind Load Certification Drawings

Document Number	Title
DPN003582	Wind Load Data Certification

This page intentionally left blank

Appendix D: Submittal Drawings

Table D.1 Submittal Drawings Contents

Document Number	Title
Planning Dimensions	
DPN003436	Cabinet and Anchor Dimensional Data 1 Fan (MCS028, MCM040, MCL055)
DPN003437	Cabinet and Anchor Dimension Data 2 Fan (MCS056, MCM080, MCL110) Dual Circuit
DPN003756	Condenser and Anchor Dimensional Data (MCM080, MCL110) Single Circuit
DPN003438	Condenser Dimensional Data 3 Fan (MCL165)
DPN003439	Condenser Dimensional Data 4 Fan (MCM160 and MCL220)
Planning Dimensions - Receiver Mounting	
DPN003839	Liebert® PDX-EEV Receiver Mounting MCS028, MCM040, and MCM080 Single Circuit Condenser Left Side Option
DPN003455	Liebert® DSE Receiver Mounting MCM Single Circuit Left Side Condenser Outlet Receiver
DPN002554	Left Side Liebert® DSE and Liebert® PDX-EEV Receiving Mounting Kit MCL055, MCL110, MCL165, MCL220 Single Circuit Compressor
DPN002383	Liebert® DSE Receiver Mounting MCM160 Circuit Dual Condenser Outlet Receivers
Planning - Condenser Elevation Above/Below Indoor Unit	
DPN003954	Air Cooled Piping Schematic Condenser above Indoor Unit
DPN003993	Air Cooled Piping Schematic Liebert® MC with Receiver above Unit
DPN003994	Air Cooled Piping Schematic Liebert® MC Mounted above Liebert® DA080-165
Piping Schematics	
DPN002188	Typical Piping Schematic for Air Cooled Liebert® DX Systems
DPN002858	General Arrangement Diagram 600mm (24in) Air Cooled with Liebert® MC Models
DPN002808	General Arrangement Diagram 300mm (12in) Air Cooled with Liebert® MC Models
DPN003730	Piping Schematic with Liebert® MC Condenser Air Cooled Scroll or Digital Scroll or Compressor Models
DPN004216	Piping Schematic with Liebert® MC Condenser Air Cooled DS077-105kW Semi-Hermetic Compressor Models
DPN002615	Piping Schematic DA050, DA080, DA085 Models with Liebert® MC
DPN002340	Piping Schematic DA125, DA150, DA165 with Liebert® MC
DPN002929	Piping Schematic Air Cooled Models with TXV
DPN003843	Piping Schematic Air Cooled Models with EEV
10034546	Piping Schematic DA125, DA150 and DA165 with Liebert® MC Without Receivers
10016389	Unit Arrangement Diagram Liebert® EconoPhase Liebert® MC without Receiver and Single Circuit Liebert® EconoPhase Unit
10016390	Piping Schematic DA050, DA080 & DA085 with Liebert® MC without Receivers
DPN002324	Unit Arrangement Diagram Liebert® MC without Receiver and Dual Circuit Liebert® EconoPhase Unit

Table D.1 Submittal Drawings Contents (continued)

Document Number	Title
Piping Connections	
DPN002166	Piping Dimensional Data Single Circuit 1 Fan, 2 Fan, 3 Fan, and 4 Fan Units
DPN002167	Piping Locations Single Circuit with Liebert® Lee-Temp
DPN002425	Piping Dimensional Data Dual Circuit 2 Fan and 4 Fan Units
DPN002426	Piping Dimensional Data with Liebert® Lee-Temp Dual Circuit Condensers
Electrical Connections	
DPN002169	Electrical Field Connections Premium Efficiency Control
DPN002374	Electrical Field Connections Premium Efficiency Control with Liebert® Lee-Temp
DPN003284	CANbus and Interlock Connections Using 1 Liebert® MC Condenser and Optional Liebert® EconoPhase Unit
DPN002361	CANbus and Interlock Connections Using 2 Liebert® MC Condensers and Optional Liebert® EconoPhase Unit
DPN003267	CANbus and Interlock Connections between Liebert® DS and Liebert® MC Condenser (Premium)
DPN002841	CANbus and Interlock Connections between 600mm (24in) and Liebert® MC (Premium)
DPN003036	CANbus and Interlock Connections between 300mm (12in) Unit and Liebert® MC (Premium)
DPN003266	CANbus and Interlocking Connections between Liebert® PDX Unit and Liebert® MC Condenser (Premium)
DPN003047	Electrical Field Connections, 575-V option
DPN002960	Installation Instructions for Installing 420 Surge Protective Device (SPD) to Liebert® MC
Seismic Anchorage Data	
DPN002414	Seismic Anchorage Data One Fan Models
DPN003582	Wind Load Data Certification

CABINET & ANCHOR DIMENSIONAL DATA 1 FAN (MCS028, MCM040, MCL055)

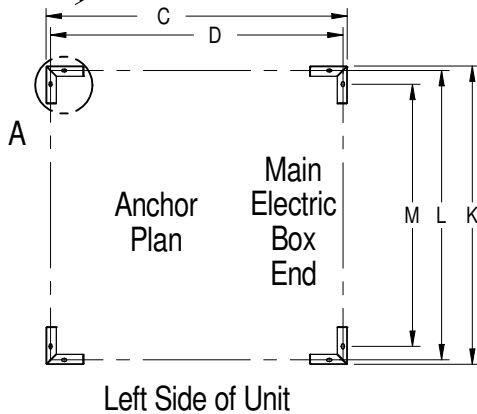
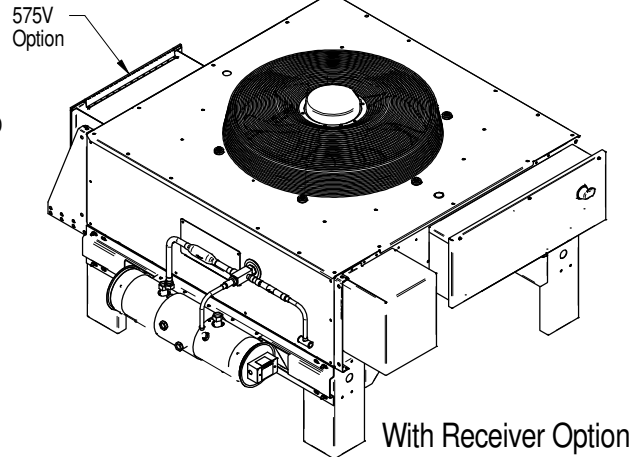
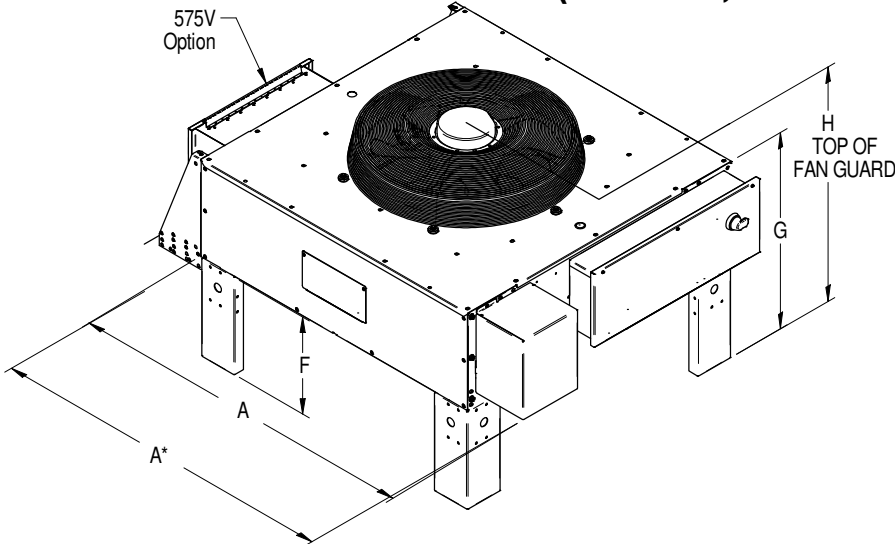

Left Side of Unit

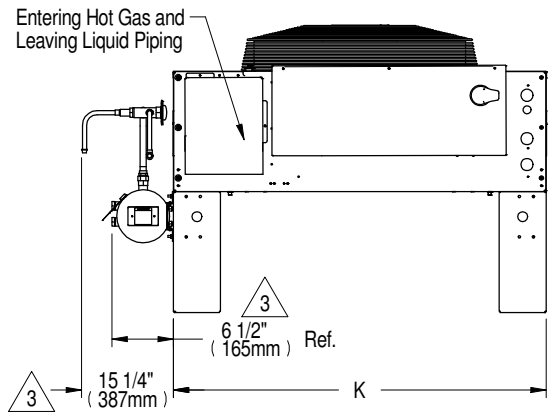

Front View (Liebert® Lee-Temp Shown)

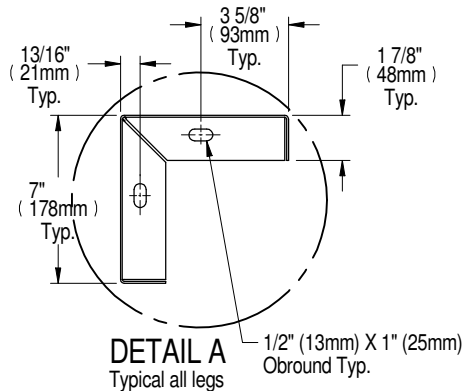

DETAIL A
Typical all legs

MODEL NUMBER	F in. (mm) (LEG HEIGHT DIMENSIONS) ²			
	18 (457)	36 (914)	48 (1219)	60 (1524)
MCS028				
MCM040				
DIM "G"	31-5/8 (803)	49-5/8 (1260)	61-5/8 (1565)	73-5/8 (1870)
DIM "H"	39-5/8 (1006)	57-5/8 (1464)	69-5/8 (1768)	81-5/8 (2073)
MCL055				
DIM "G"	35-7/8 (911)	53-7/8 (1368)	65-7/8 (1673)	77-7/8 (1978)
DIM "H"	43-5/8 (1108)	61-5/8 (1565)	73-5/8 (1870)	85-5/8 (2175)

Note:

- Vertiv recommends a clearance of 36" (915mm) on each side for proper operation and component access.
- ² Cross Bracing required for legs longer than 18" (457.2mm). Quantity varies per model & options selected.
- ³ For Liebert® PDX w/EEV systems & unheated refrigerant receivers, 6-1/2" (165mm) is 9-1/4" (235mm) and 15-1/4" (387) is not applicable.

MODEL NUMBER	A in (mm)	A* in (mm) (575V ONLY)	C in (mm)	D in (mm)	K in (mm)	L in (mm)	M in (mm)
MCS028	50-5/8 (1287)	58-7/8 (1495)	44-1/8 (1120)	42-1/2 (1080)	42-1/2 (1080)	40-7/8 (1038)	35-7/8 (910)
MCM040	57-3/16 (1453)	65-3/8 (1661)	48 (1219)	46-5/16 (1177)	46 (1168)	44-3/8 (1127)	39-5/16 (999)
MCL055	68 (1727)	77 (1956)	56 (1422)	54-3/8 (1381)	55-1/2 (1410)	53-7/8 (1368)	48-3/4 (1238)

CABINET & ANCHOR DIMENSIONAL DATA 2 FAN (MCS056, MCM080, MCL110) DUAL CIRCUIT

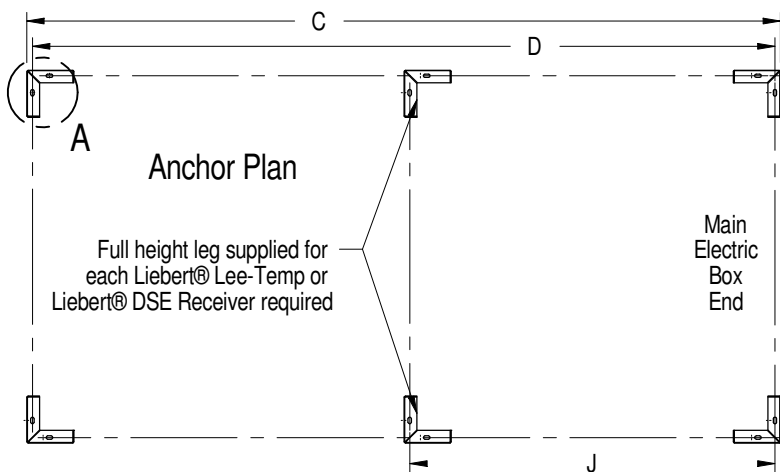
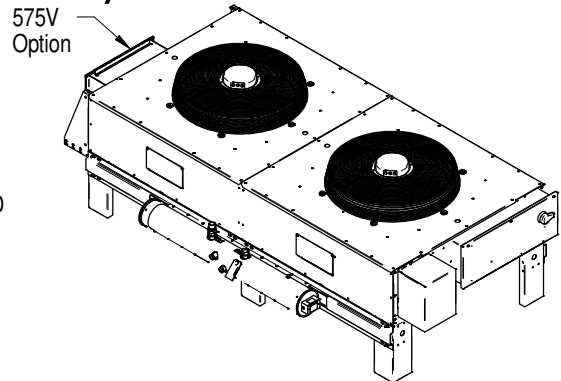
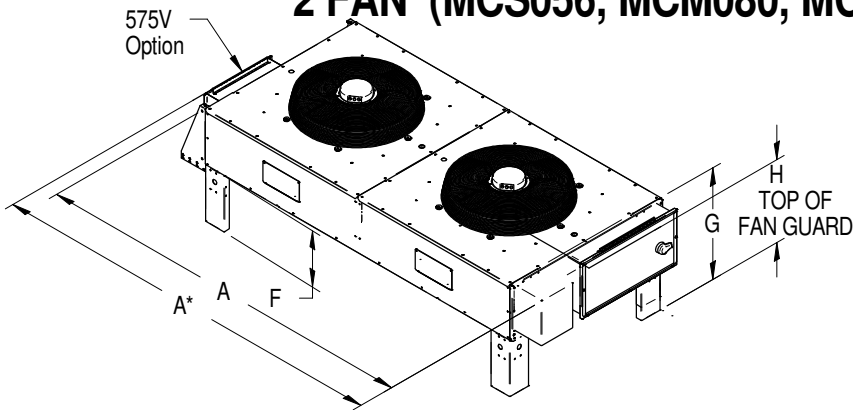

Liebert® Lee-Temp or Liebert® DSE Receiver (optional)

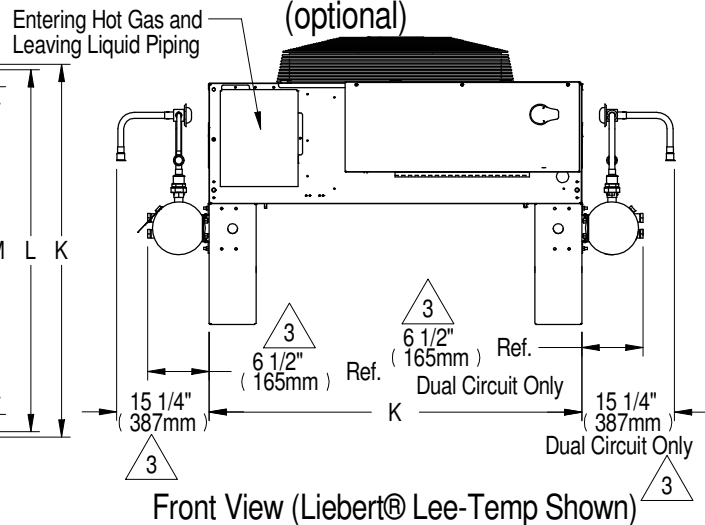

Left Side of Unit Liebert® Lee-Temp or Liebert® DSE Only with optional receiver

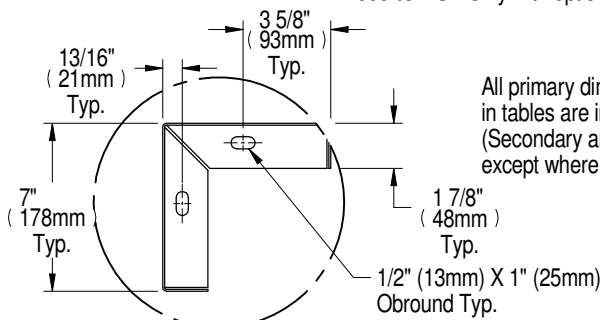

DETAIL A
Typical All Legs

All primary dimensions in tables are in inches (Secondary are in mm) except where specified

MODEL NUMBER	F 2 (LEG HEIGHT DIMENSIONS)			
	18 (457)	36 (914)	48 (1219)	60 (1524)
MCS056	18 (457)	36 (914)	48 (1219)	60 (1524)
MCM080	31-5/8 (803)	49-5/8 (1260)	61-5/8 (1565)	73-5/8 (1870)
MCL110	35-7/8 (911)	53-7/8 (1368)	65-7/8 (1673)	77-7/8 (1978)
	43-5/8 (1108)	61-5/8 (1565)	73-5/8 (1870)	85-5/8 (2175)

Note:

1. Vertiv recommends a clearance of 36" (915mm) on each side for proper operation and component access.

2 Cross bracing required for legs longer than 18" (457mm). Quantity varies per model & options selected.

3 For Liebert® DSE models with optional receiver, 6-1/2" (165mm) dimension is 9-1/4" (235mm) and 15-1/4" (387mm) dimension is not applicable.

MODEL NUMBER	A	A* (575V ONLY)	C	D	J Liebert® Lee-Temp or Liebert® DSE Receivers optional	K	L	M
MCS056	94-7/8 (2411)	103-1/8 (2619)	88-3/8 (2245)	86-3/4 (2203)	42-1/2 (1079)	42-1/2 (1080)	40-7/8 (1038)	35-7/8 (910)
MCM080	105-1/4 (2674)	113-7/16 (2882)	96-1/16 (2440)	94-7/16 (2398)	46-5/16 (1177)	46 (1168)	44-3/8 (1127)	39-5/16 (999)
MCL110	124-1/8 (3152)	133-1/8 (3381)	112-1/8 (2848)	110-1/2 (2806)	54-3/8 (1381)	55-1/2 (1410)	53-7/8 (1368)	48-3/4 (1238)

CABINET & ANCHOR DIMENSIONAL DATA 2 FAN (MCM080, MCL110) SINGLE CIRCUIT

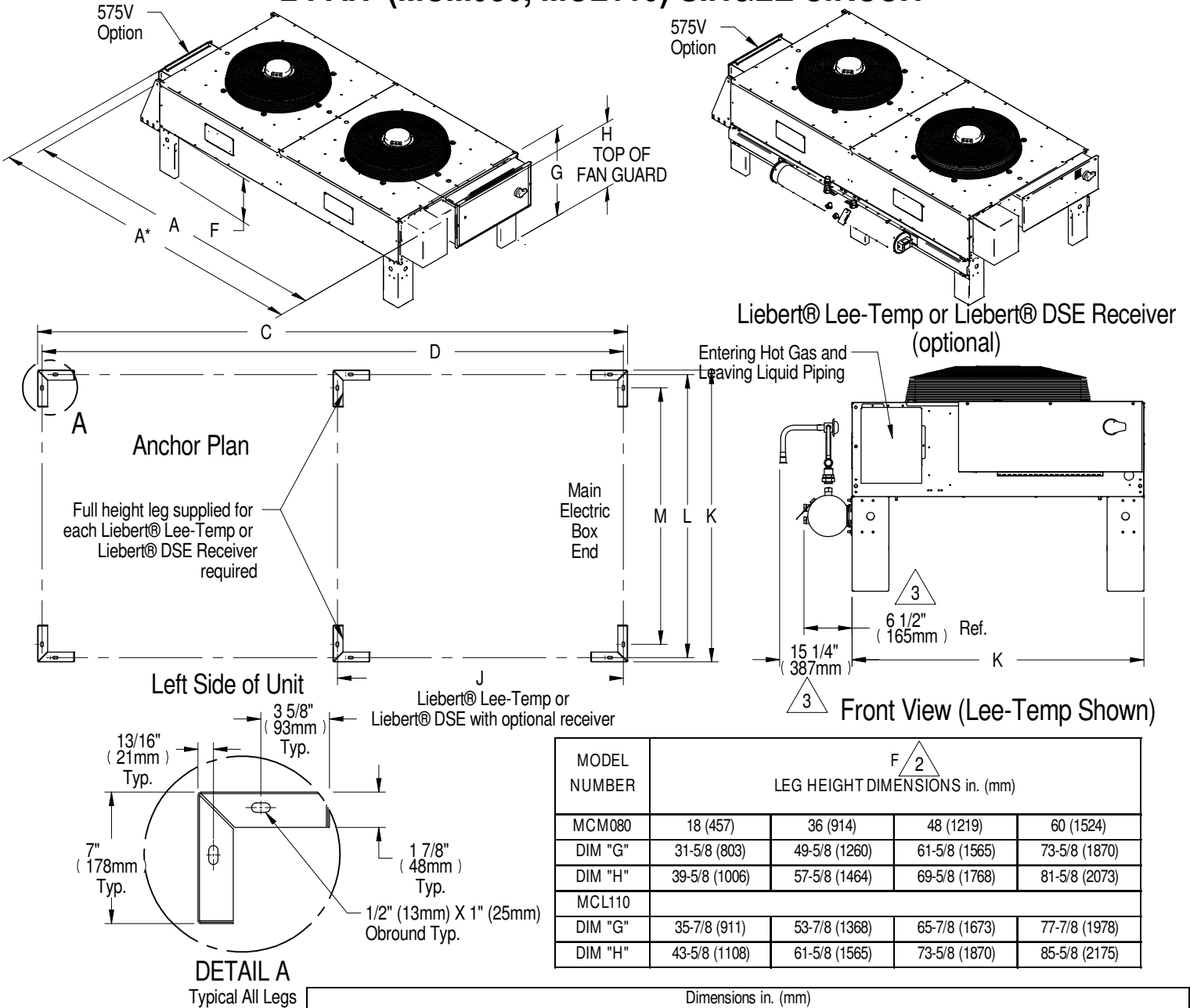

Note:
1. Vertiv recommends a clearance of 36" (915mm) on each side for proper operation and component access.

2. Cross bracing required for legs longer than 18" (457mm). Quantity varies per model & options selected.
3. For Liebert® DSE models with optional receiver, 6-1/2" (165mm) dimension is 9-1/4" (235mm) and 15-1/4" (387mm) dimension is not applicable.

CABINET & ANCHOR DIMENSIONAL DATA 3 FAN (MCL165)

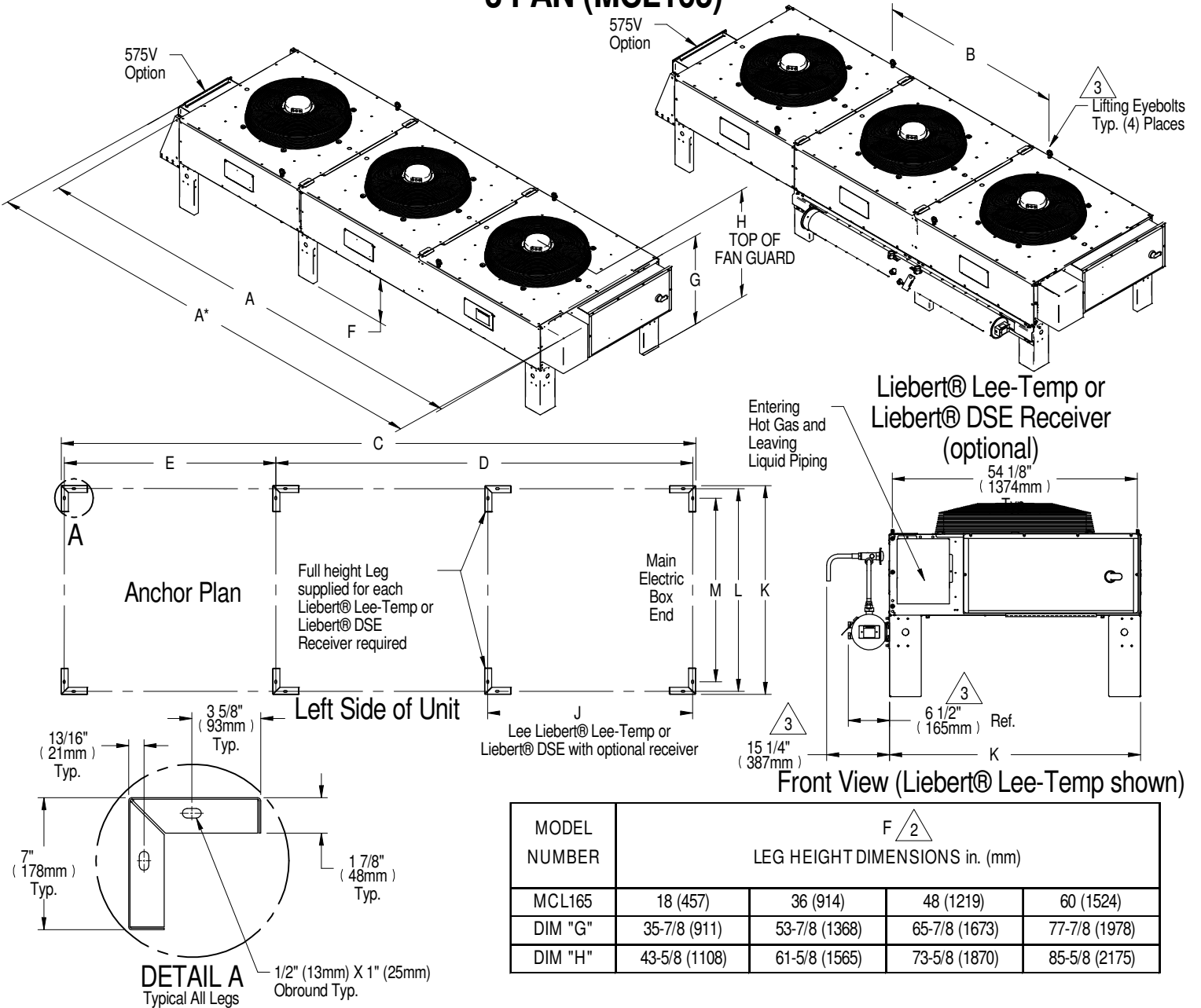

MODEL NUMBER	LEG HEIGHT DIMENSIONS in. (mm)			
	F 2			
MCL165	18 (457)	36 (914)	48 (1219)	60 (1524)
DIM "G"	35-7/8 (911)	53-7/8 (1368)	65-7/8 (1673)	77-7/8 (1978)
DIM "H"	43-5/8 (1108)	61-5/8 (1565)	73-5/8 (1870)	85-5/8 (2175)

Dimensions in. (mm)										
MODEL NUMBER	A	A* (575V ONLY)	B	C	D	E	J Liebert® Lee-Temp or Liebert® DSE Receiver optional	K	L	M
MCL165	180-1/4 (4578)	189-1/4 (4807)	73-7/16 (1866)	168-1/4 (4274)	110-1/2 (2806)	56-1/8 (1425)	54-3/8 (1381)	55-1/2 (1410)	53-7/8 (1368)	48-3/4 (1238)

Note:

1. Vertiv recommends a clearance of 36" (915mm) on each side for proper operation and component access.

2. Cross Bracing required for legs longer than 18" (457.2mm). quantity varies per model & options selected.

3. For Liebert® DSE models with optional receiver, 6-1/2" (165mm) dimension is 9-1/4" (235mm) and 15-1/4" (387mm) dimension is not applicable.

CABINET & ANCHOR DIMENSIONAL DATA

4 FAN (MCM160, MCL220)

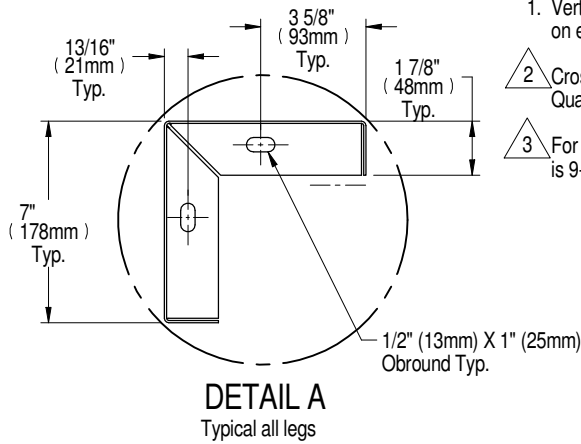
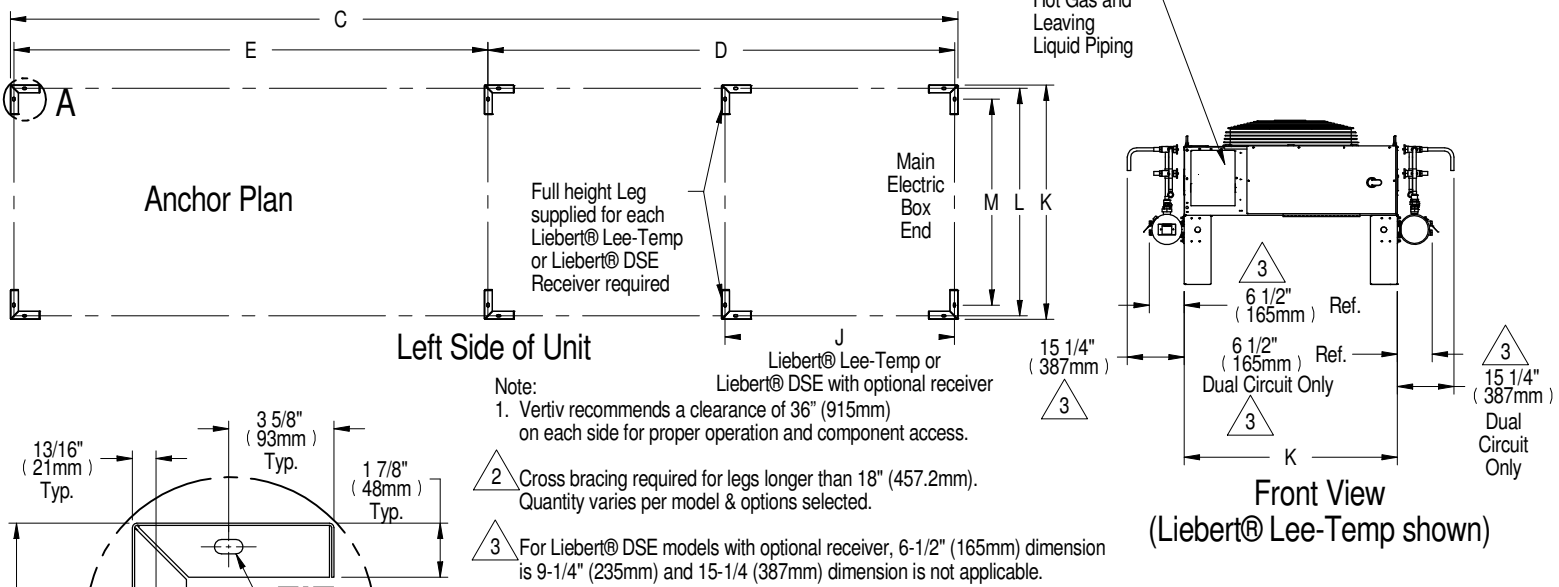
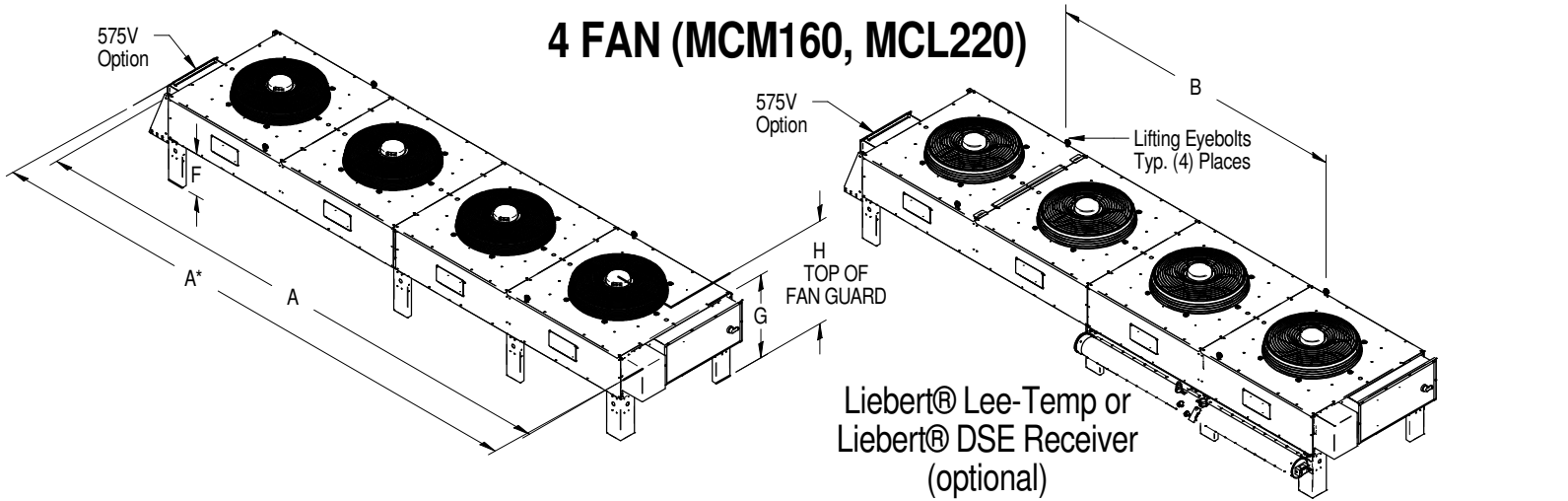

MODEL NUMBER	LEG HEIGHT DIMENSIONS in. (mm)			
	18 (457)	36 (914)	48 (1219)	60 (1524)
MCM160				
DIM "G"	31-5/8 (803)	49-5/8 (1260)	61-5/8 (1565)	73-5/8 (1870)
DIM "H"	39-5/8 (1006)	57-5/8 (1464)	69-5/8 (1768)	81-5/8 (2073)
MCL220				
DIM "G"	35-7/8 (911)	53-7/8 (1368)	65-7/8 (1673)	77-7/8 (1978)
DIM "H"	43-5/8 (1108)	61-5/8 (1565)	73-5/8 (1870)	85-5/8 (2175)

MODEL NUMBER	Dimensions in. (mm)									
	A	A* (575V ONLY)	B	C	D	E	J Liebert® Lee-Temp or Liebert® DSE Receiver optional	K	L	M
MCM160	202-7/16 (5142)	210-5/8 (5350)	113-1/2 (2883)	192-1/4 (4883)	94-7/16 (2398)	96-3/16 (2444)	46-5/16 (1177)	46 (1168)	44-3/8 (1127)	39-5/16 (999)
MCL220	236-5/16 (6003)	245-5/16 (6231)	129-9/16 (3291)	224-3/8 (5699)	110-1/2 (2806)	112-1/4 (2851)	54-3/8 (1381)	55-1/2 (1410)	53-7/8 (1368)	48-3/4 (1238)

PDX-EEV RECEIVER MOUNTING MCS028, MCM040, MCM080 SINGLE CIRCUIT CONDENSER LEFT SIDE OPTION

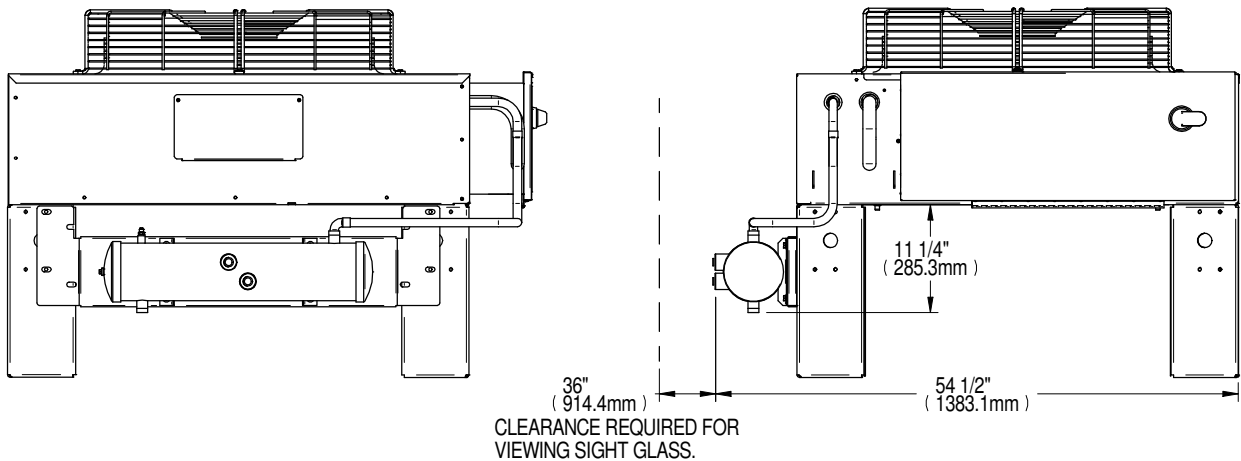
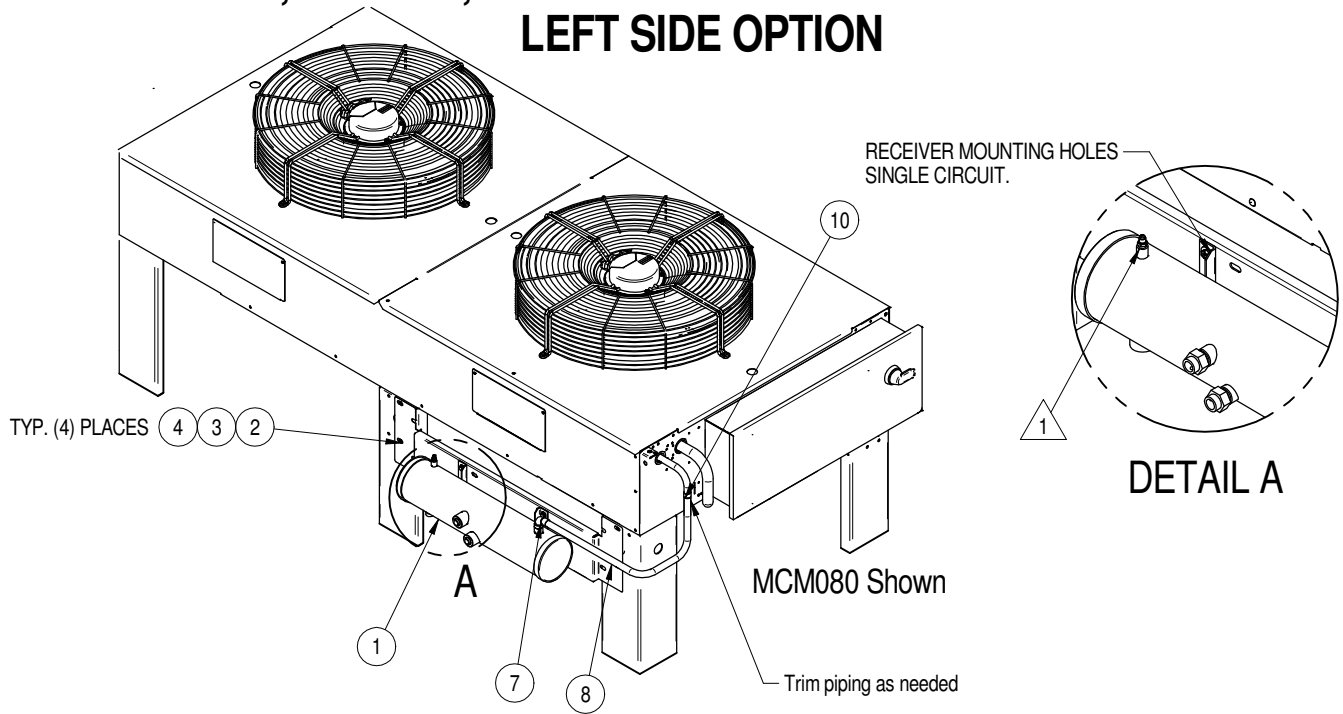

ITEM NO.	DESCRIPTION	QTY
1	RECEIVER AND BRACKET ASSEMBLY	1
2	CAP SCREW HXDIN933M8-1.25X25A2	8
3	FENDER WASHER DIN9021 M8X24 A2	12
4	LOCK NUT HEX NYL INSR M8	8
7	90° ELBOW FTGXC 7/8" CU	1
8	COPPER FORMED TUBE 7/8"	1
10	REDUCER CU CXC 7/8"X5/8"	1

NOTES:

1. SCHRADER PORT FOR PROOF PRESSURE RELIEF ONLY & ACCESS NOT REQUIRED AFTER PIPING.

Liebert® MC Hot Gas/Receiver Outlet Connection Sizes*

MODEL NO.	CONNECTION SIZES, OD, IN	
	HOT GAS LINE	RECEIVER OUTLET (LIQUID LINE)
MCS 028	7/8	1-3/8
MCM 040	7/8	1-3/8
MCM 080	1-1/8	1-3/8

*Consult DPN000788 for Hot Gas & Liquid Line sizes required between indoor and outdoor units.

**PDX-EEV RECEIVER MOUNTING
MCS028, MCM040, MCM080 SINGLE CIRCUIT CONDENSER
RIGHT SIDE OPTION**

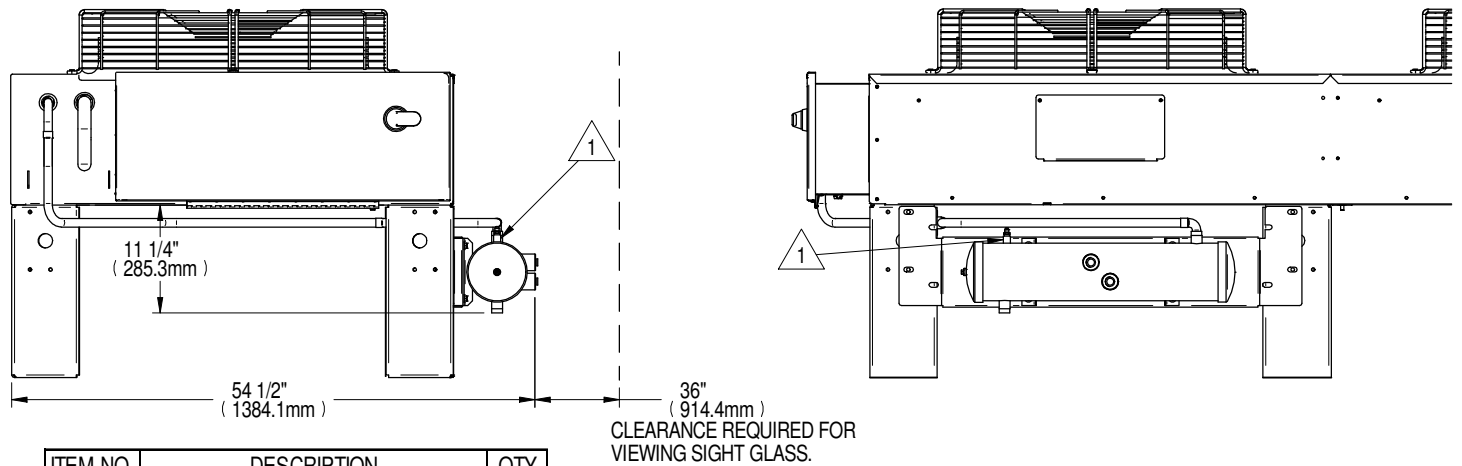
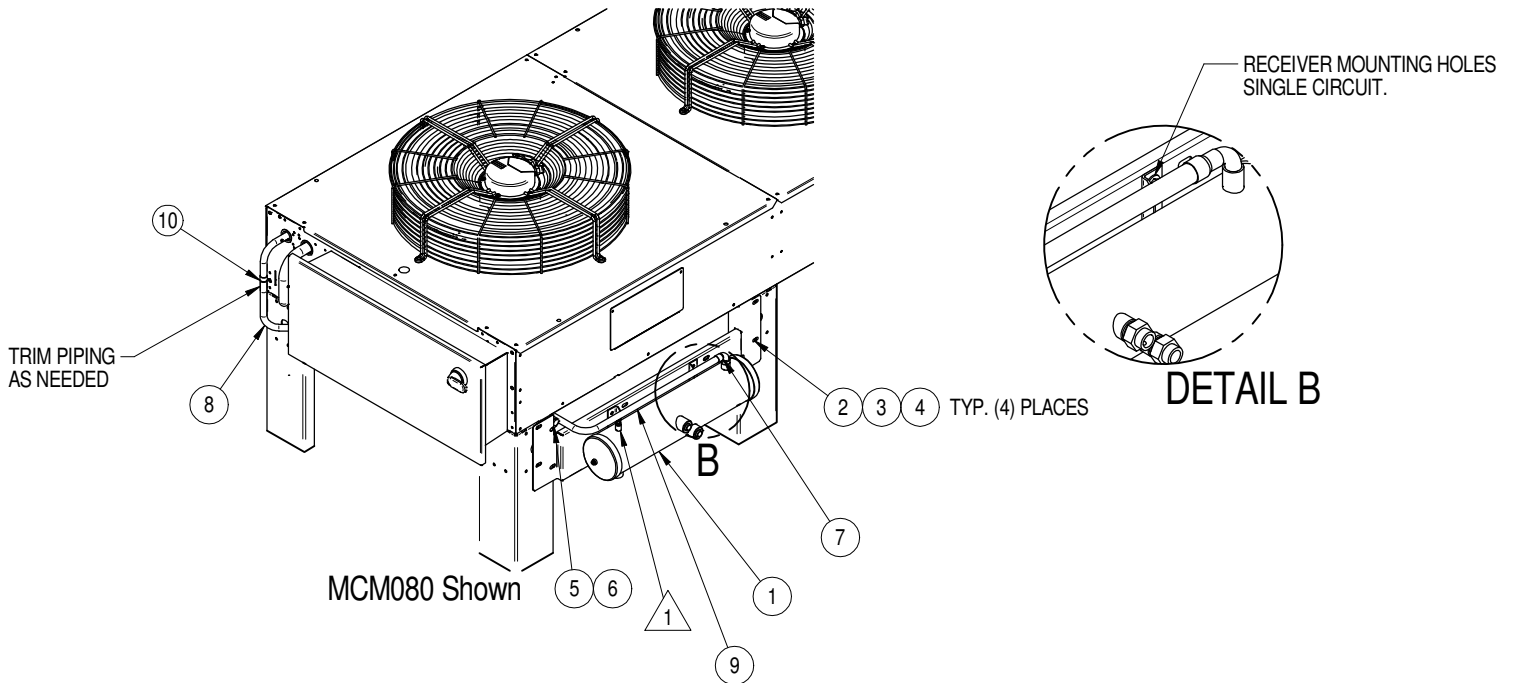

ITEM NO.	DESCRIPTION	QTY
1	RECEIVER AND BRACKET ASSEMBLY	1
2	CAP SCREW HXDIN933M8-1.25X25A2	8
3	FENDER WASHER DIN9021 M8X24 A2	12
4	LOCK NUT HEX NYL INSR M8	8
5	CLAMP OMEGA 7/8"	1
6	SCREW SD HWH YZ 10-16 X 5/8	2
7	90° ELBOW FTGXC 7/8" CU	1
8	COPPER FORMED TUBE 7/8"	1
9	COPPER FORMED TUBE 7/8"	1
10	REDUCER CU CXC 7/8"X5/8"	1

NOTES:

1. SCHRADER PORT FOR PROOF PRESSURE RELIEF ONLY & ACCESS NOT REQUIRED AFTER PIPING.

Liebert® MC Hot Gas/Receiver Outlet Connection Sizes*

MODEL NO.	CONNECTION SIZES, OD, IN	
	HOT GAS LINE	RECEIVER OUTLET (LIQUID LINE)
MCS 028	7/8	1-3/8
MCM 040	7/8	1-3/8
MCM 080	1-1/8	1-3/8

*Consult DPN000788 for Hot Gas & Liquid Line sizes required between indoor and outdoor units.

LIEBERT® DSE RECEIVER MOUNTING
MCM SINGLE CIRCUIT LEFT SIDE CONDENSER OUTLET RECEIVER

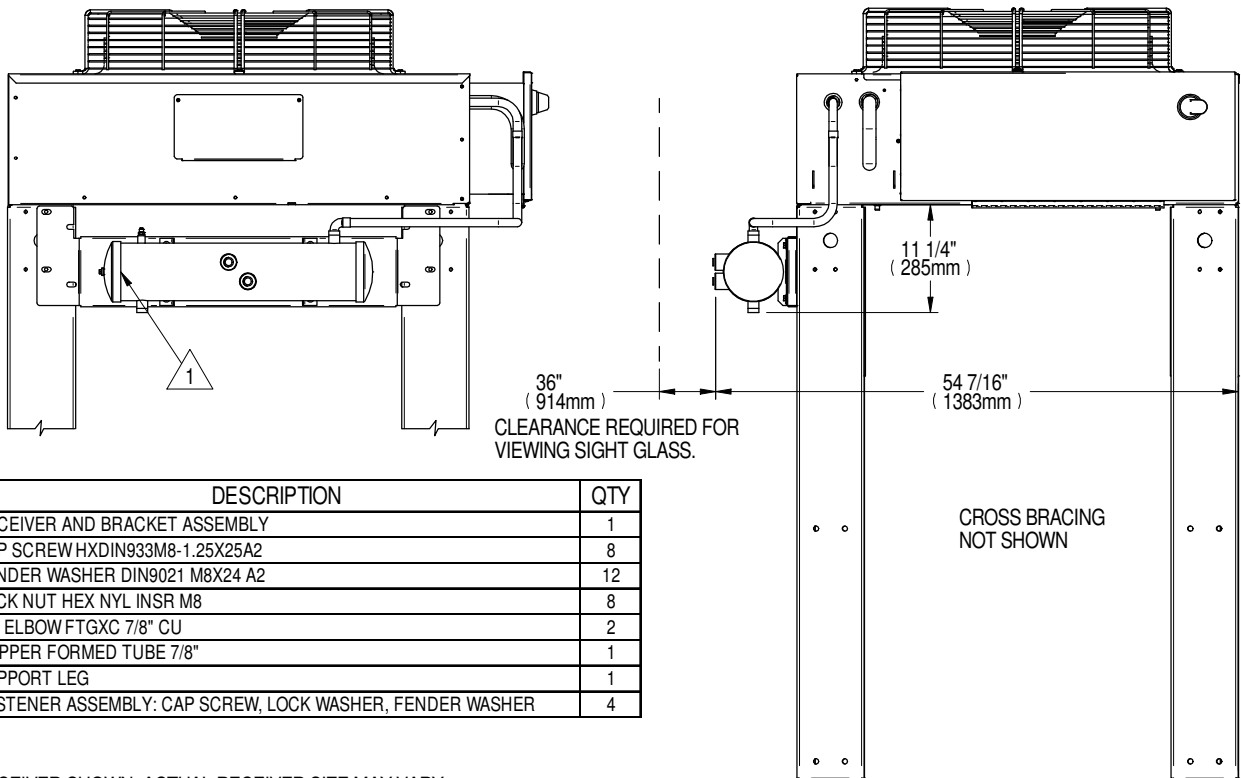
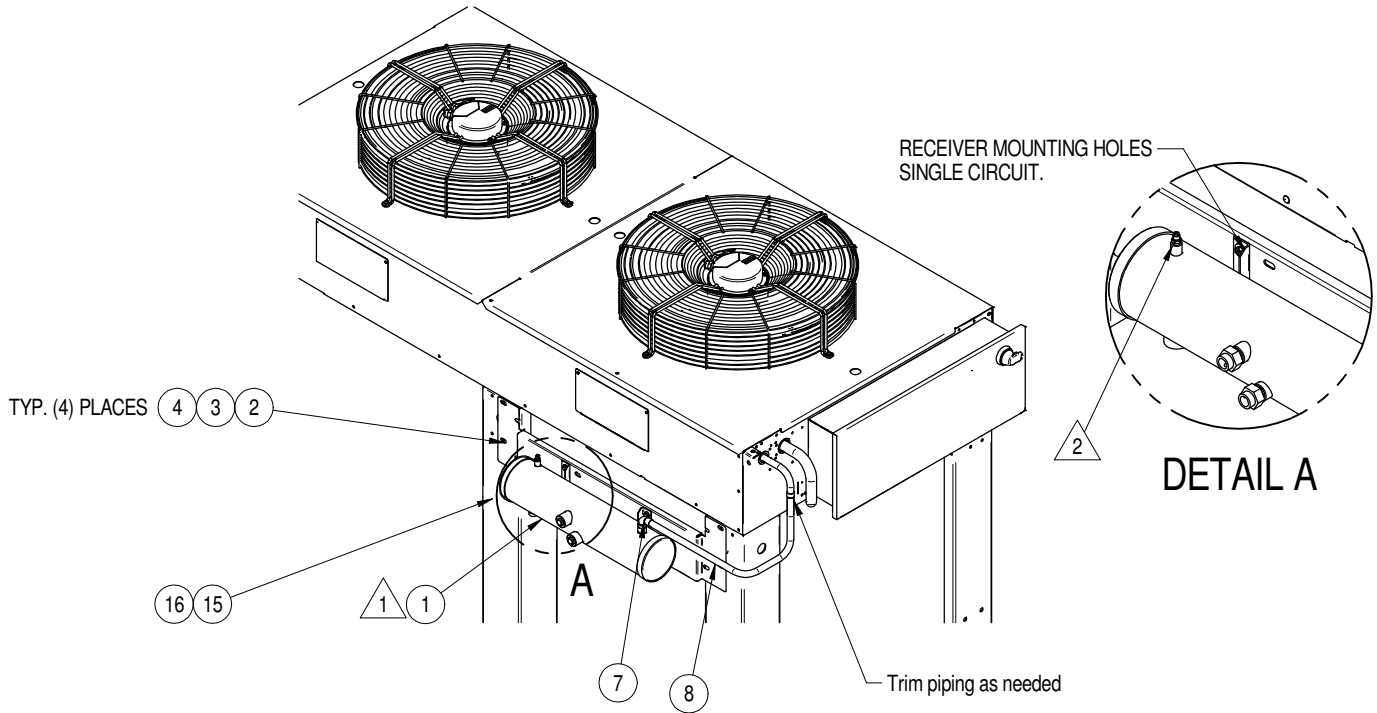

ITEM NO.	DESCRIPTION	QTY
1	RECEIVER AND BRACKET ASSEMBLY	1
2	CAP SCREW HXDIN933M8-1.25X25A2	8
3	FENDER WASHER DIN9021 M8X24 A2	12
4	LOCK NUT HEX NYL INSR M8	8
7	90° ELBOW FTGXC 7/8" CU	2
8	COPPER FORMED TUBE 7/8"	1
15	SUPPORT LEG	1
16	FASTENER ASSEMBLY: CAP SCREW, LOCK WASHER, FENDER WASHER	4

NOTES

- 1. SMALL RECEIVER SHOWN. ACTUAL RECEIVER SIZE MAY VARY.
- 2. SCHRADER PORT FOR PROOF PRESSURE RELIEF ONLY & ACCESS NOT REQUIRED AFTER PIPING.

LIEBERT® DSE RECEIVER MOUNTING MCM080 SINGLE CIRCUIT RIGHT SIDE CONDENSER OUTLET RECEIVER

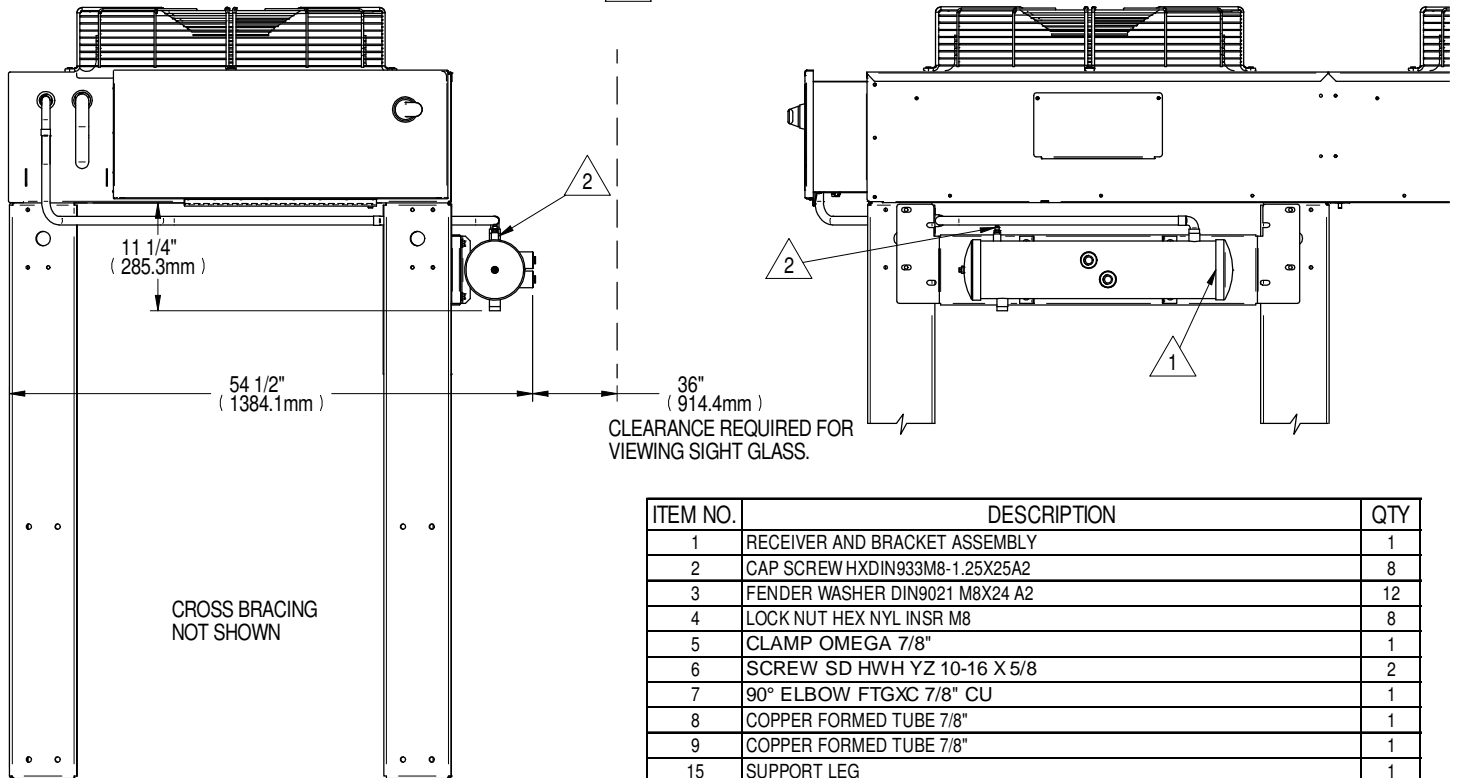
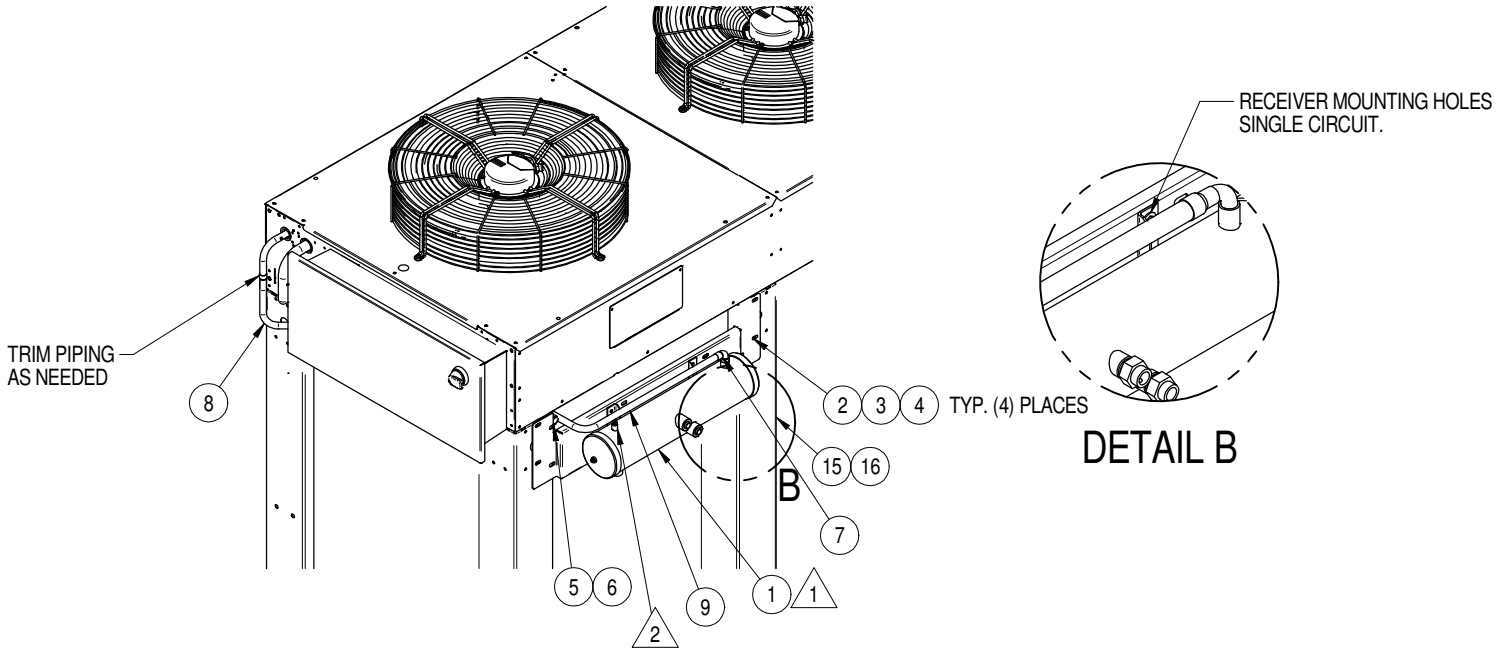

ITEM NO.	DESCRIPTION	QTY
1	RECEIVER AND BRACKET ASSEMBLY	1
2	CAP SCREW HXDIN933M8-1.25X25A2	8
3	FENDER WASHER DIN9021 M8X24 A2	12
4	LOCK NUT HEX NYL INSR M8	8
5	CLAMP OMEGA 7/8"	1
6	SCREW SD HWH YZ 10-16 X 5/8	2
7	90° ELBOW FTGXC 7/8" CU	1
8	COPPER FORMED TUBE 7/8"	1
9	COPPER FORMED TUBE 7/8"	1
15	SUPPORT LEG	1
16	FASTENER ASSEMBLY: CAP SCREW, LOCK WASHER, FENDER WASHER	4

NOTES

- 1. SMALL RECEIVER SHOWN. ACTUAL RECEIVER SIZE MAY VARY.
- 2. SCHRADER PORT FOR PROOF PRESSURE RELIEF ONLY & ACCESS NOT REQUIRED AFTER PIPING.

LEFT SIDE LIEBERT® DSE & LIEBERT® PDX-EEV RECEIVER MOUNTING KIT

MCL055, MCL110, MCL165 & MCL220 SINGLE CIRCUIT CONDENSER

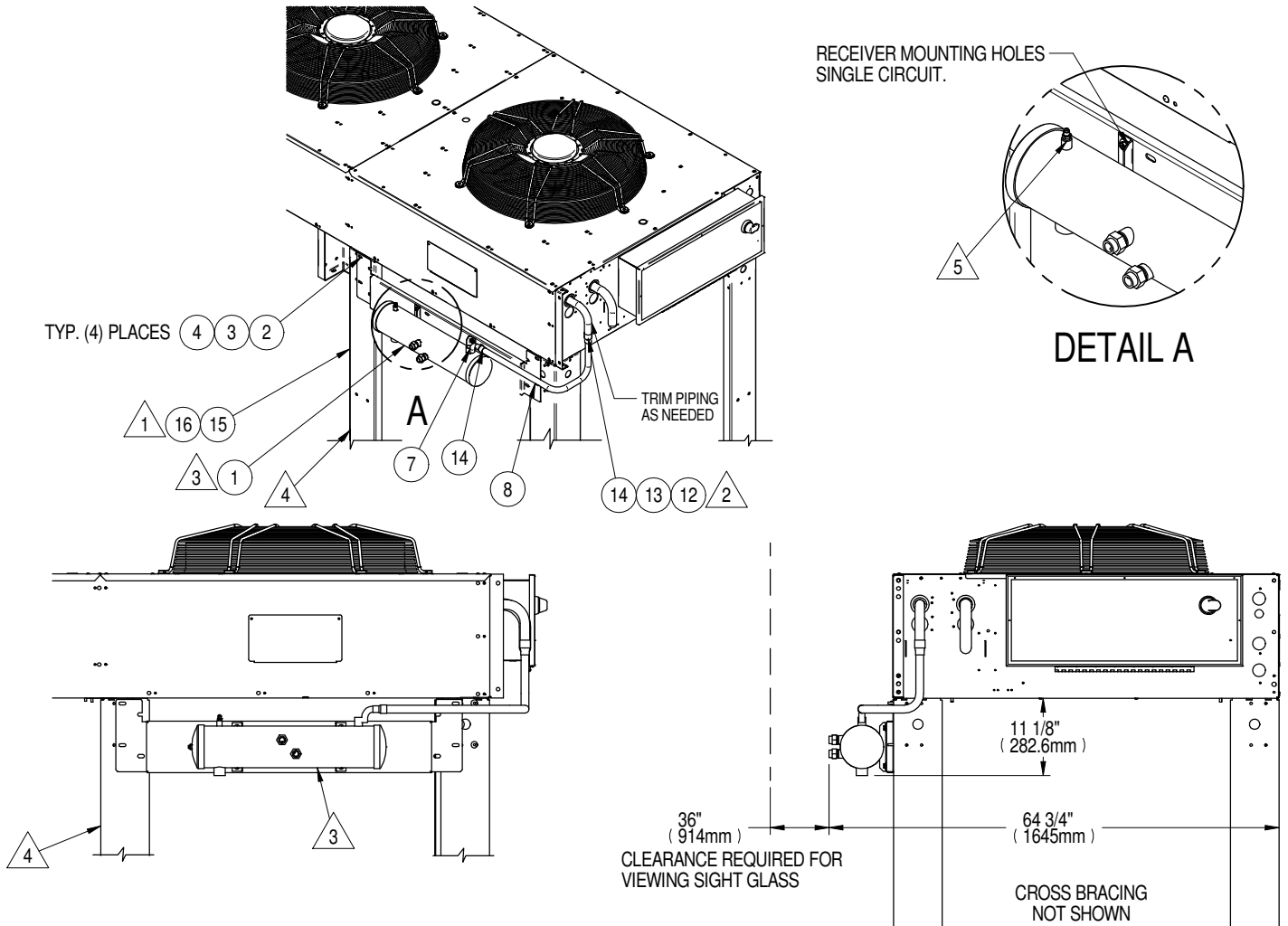

ITEM NO.	DESCRIPTION	QTY
1	RECEIVER AND BRACKET ASSEMBLY	1
2	CAP SCREW HXDIN933M8-1.25X25A2	8
3	FENDER WASHER DIN9021 M8X24 A2	12
4	LOCK NUT HEX NYL INSR M8	8
7	90° ELBOW FTGXFTG 7/8" CU	1
8	COPPER FORMED TUBE 1-1/8"	1
12	COUPLING CU 1-1/8"	1
13	REDUCER CU CXC 1-3/8"X1-1/8"	1
14	REDUCER CU CXC 1-1/8"X7/8"	2
15	SUPPORT LEG	1
16	FASTENER ASSEMBLY: CAP SCREW, LOCK WASHER, FENDER WASHER	4

- NOTES:
1. USE ITEMS 15 AND 16 AS NEEDED FOR MOUNTING OF ITEM 1.
 2. ITEM 12 TO BE USED ON MCL110 & MCL165 UNITS.
ITEM 13 TO BE USED ON MCL220 UNITS.
ITEM 14 TO BE USED ON MCL055 UNITS.
 3. SMALL RECEIVER SHOWN. ACTUAL RECEIVER SIZE MAY VARY.
 4. RECEIVER LEG IS SAME HEIGHT AS OTHER LEGS AND NEEDS TO BE ANCHORED WITH THEM.
 5. SCHRADER PORT FOR PROOF PRESSURE RELIEF ONLY & ACCESS NOT REQUIRED AFTER PIPING.

LIEBERT MC CONDENSER

RIGHT SIDE LIEBERT® DSE & LIEBERT® PDX-EEV RECEIVER MOUNTING KIT

MCL055, MCL110, MCL165 & MCL220 SINGLE CIRCUIT CONDENSER

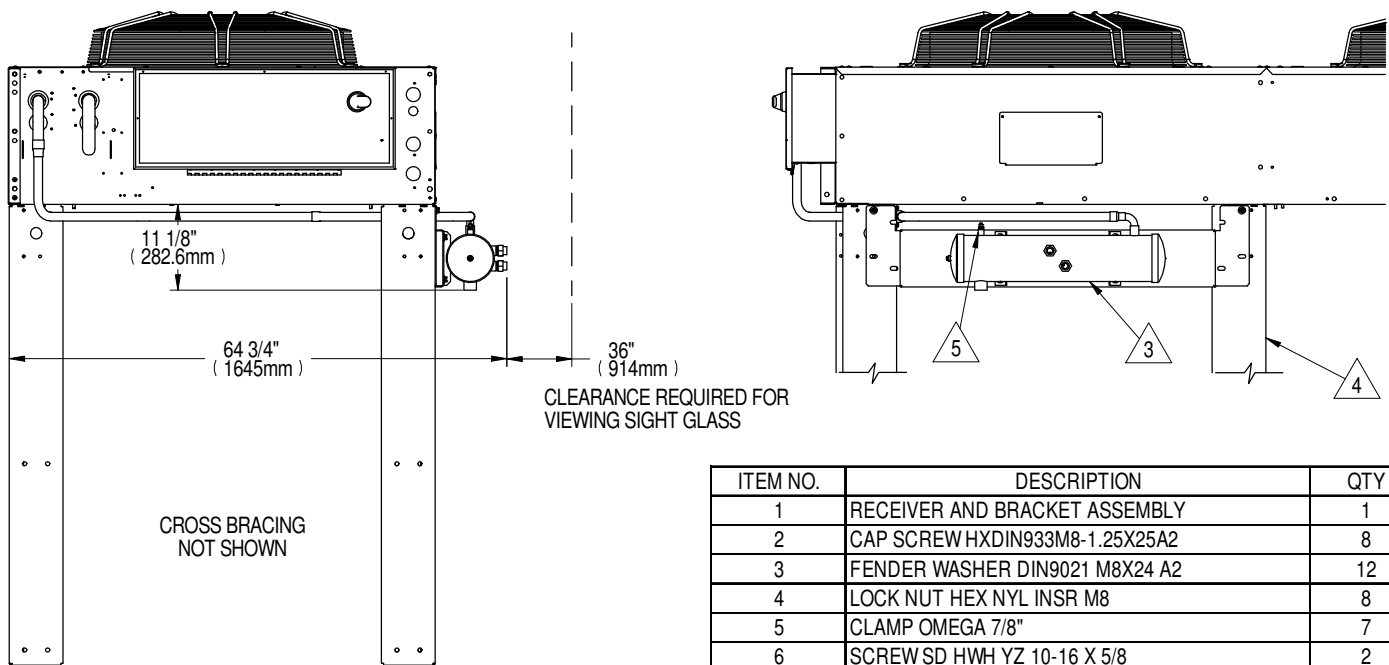
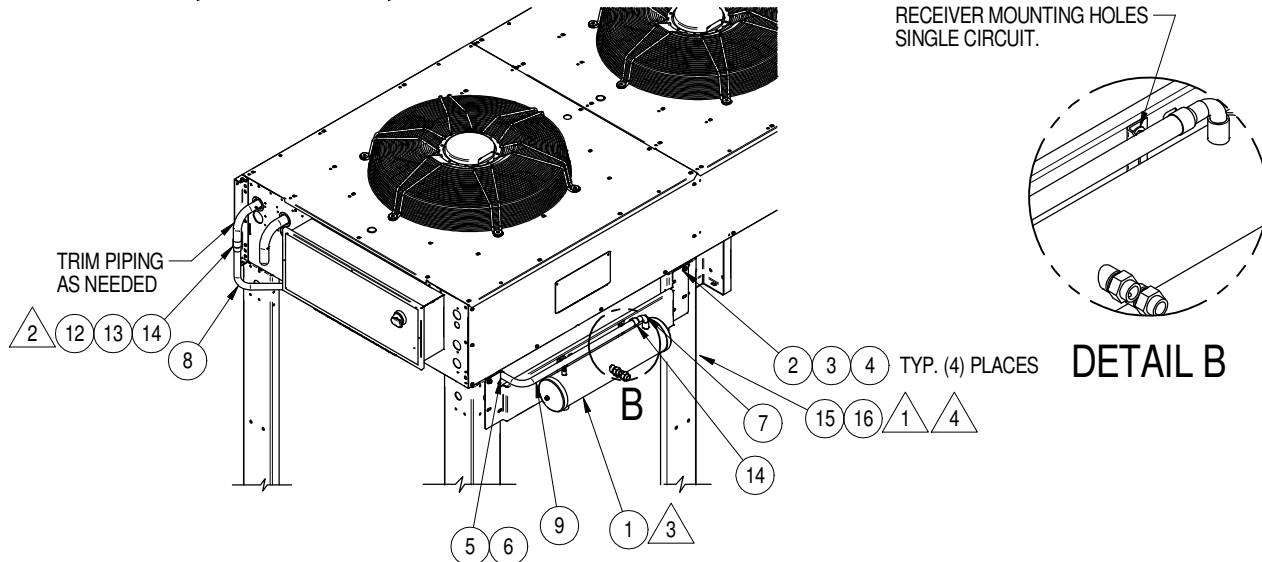

NOTES:

- 1. USE ITEMS 15 AND 16 AS NEEDED FOR MOUNTING OF ITEM 1.
- 2. ITEM 12 TO BE USED ON MCL110 & MCL165 UNITS.
ITEM 13 TO BE USED ON MCL220 UNITS.
ITEM 14 TO BE USED ON MCL055 UNITS.
- 3. SMALL RECEIVER SHOWN. ACTUAL RECEIVER SIZE MAY VARY.
- 4. RECEIVER LEG IS SAME HEIGHT AS OTHER LEGS AND NEEDS TO BE ANCHORED WITH THEM.
- 5. SCHRADER PORT FOR PROOF PRESSURE RELIEF ONLY & ACCESS NOT REQUIRED AFTER PIPING.

ITEM NO.	DESCRIPTION	QTY
1	RECEIVER AND BRACKET ASSEMBLY	1
2	CAP SCREW HXDIN933M8-1.25X25A2	8
3	FENDER WASHER DIN9021 M8X24 A2	12
4	LOCK NUT HEX NYL INSR M8	8
5	CLAMP OMEGA 7/8"	7
6	SCREW SD HWH YZ 10-16 X 5/8	2
7	90° ELBOW FTGXFTG 7/8" CU	1
8	COPPER FORMED TUBE 1-1/8"	1
9	COPPER FORMED TUBE 1-1/8"	2
12	COUPLING CU 1-1/8"	1
13	REDUCER CU CXC 1-3/8"X1-1/8"	1
14	REDUCER CU CXC 1-1/8"X7/8"	2
15	SUPPORT LEG	1
16	FASTENER ASSEMBLY: CAP SCREW, LOCK WASHER, FENDER WASHER	4

LIEBERT® DSE RECEIVER MOUNTING KITS MCL110 & MCL220 DUAL CIRCUIT CONDENSER

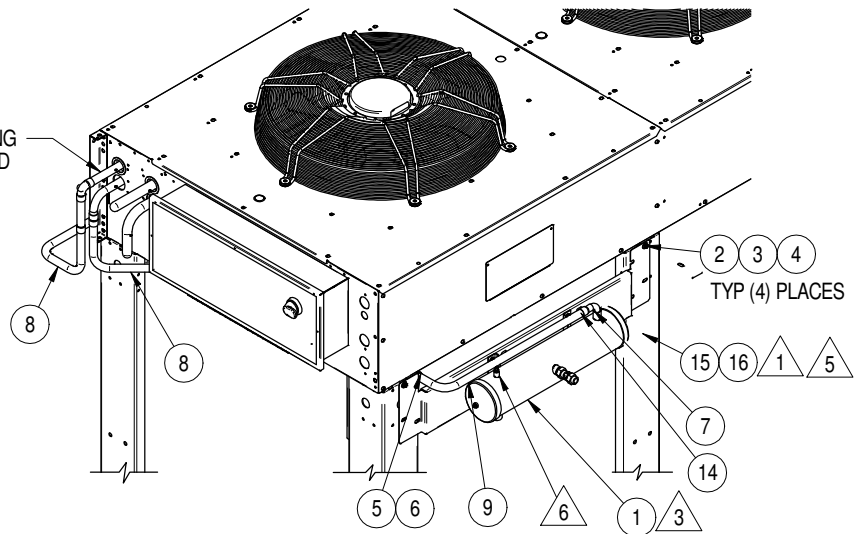
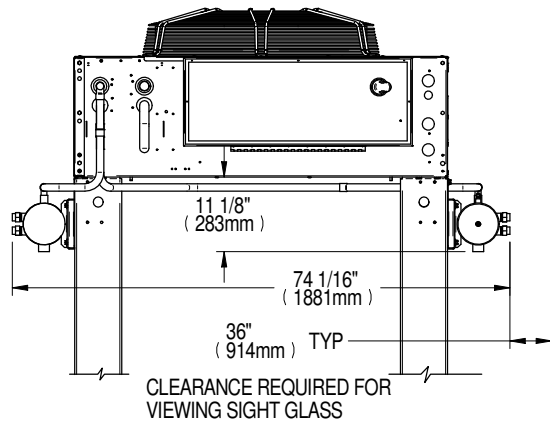
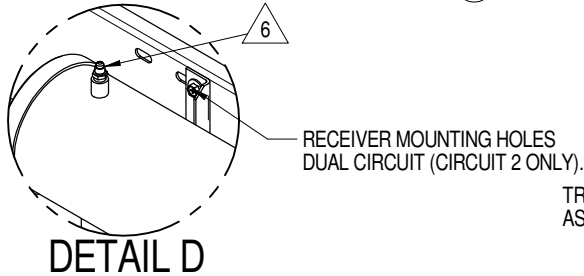
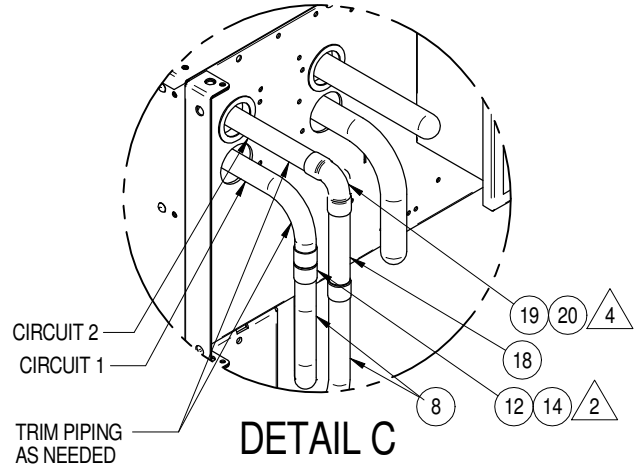
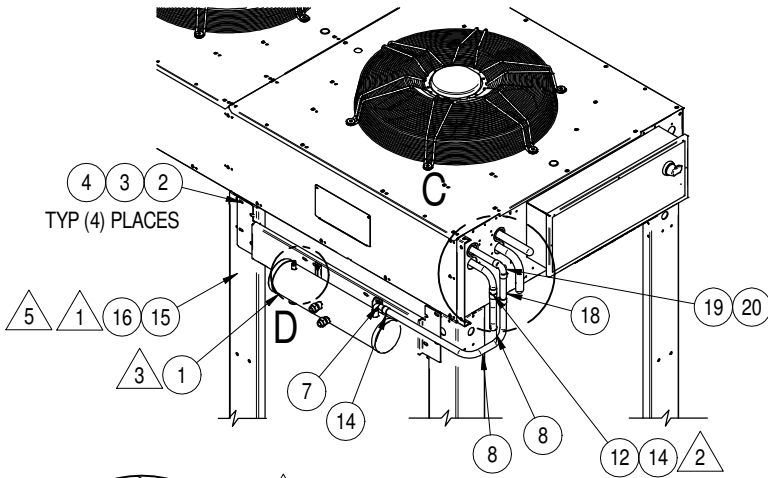

NOTES:

1. USE ITEMS 15 AND 16 AS NEEDED FOR MOUNTING OF ITEM 1.
2. ITEM 14 TO BE USED ON MCL110 UNITS.
ITEM 12 TO BE USED ON MCL220 UNITS.
3. SMALL RECEIVER SHOWN. ACTUAL RECEIVER SIZE MAY VARY.
4. ITEM 20 TO BE USED ON MCL110 UNITS.
ITEM 19 TO BE USED ON MCL220 UNITS.
5. RECEIVER LEG IS SAME HEIGHT AS OTHER LEGS AND NEEDS TO BE ANCHORED WITH THEM.
6. SCHRADER PORT FOR PROOF PRESSURE RELIEF ONLY & ACCESS NOT REQUIRED AFTER PIPING.

ITEM NO.	DESCRIPTION	QTY
1	RECEIVER AND BRACKET ASSEMBLY	2
2	CAP SCREW HXDIN933M8-1.25X25A2	12
3	FENDER WASHER DIN9021 M8X24 A2	20
4	LOCK NUT HEX NYL INSR M8	12
5	CLAMP OMEGA 7/8"	1
6	SCREW SD HWH YZ 10-16 X 5/8	2
7	90° ELBOW FTGXFTG 7/8" CU	2
8	COPPER FORMED TUBE 1-1/8"	2
9	COPPER FORMED TUBE 1-1/8"	1
12	COUPLING CU 1-1/8"	1
14	REDUCER CU CXC 1-1/8"X7/8"	4
15	SUPPORT LEG	2
16	FASTENER ASSEMBLY: CAP SCREW, LOCK WASHER, FENDER WASHER	8
18	COPPER TUBE 1-1/8" SWAGED	1
19	90° ELBOW CXC 1-1/8" CU	1
20	90° ELBOW CXC 1-1/8"X7/8" CU	1

LIEBERT® DSE RECEIVER MOUNTING MCM160 DUAL CIRCUIT DUAL CONDENSER OUTLET RECEIVERS

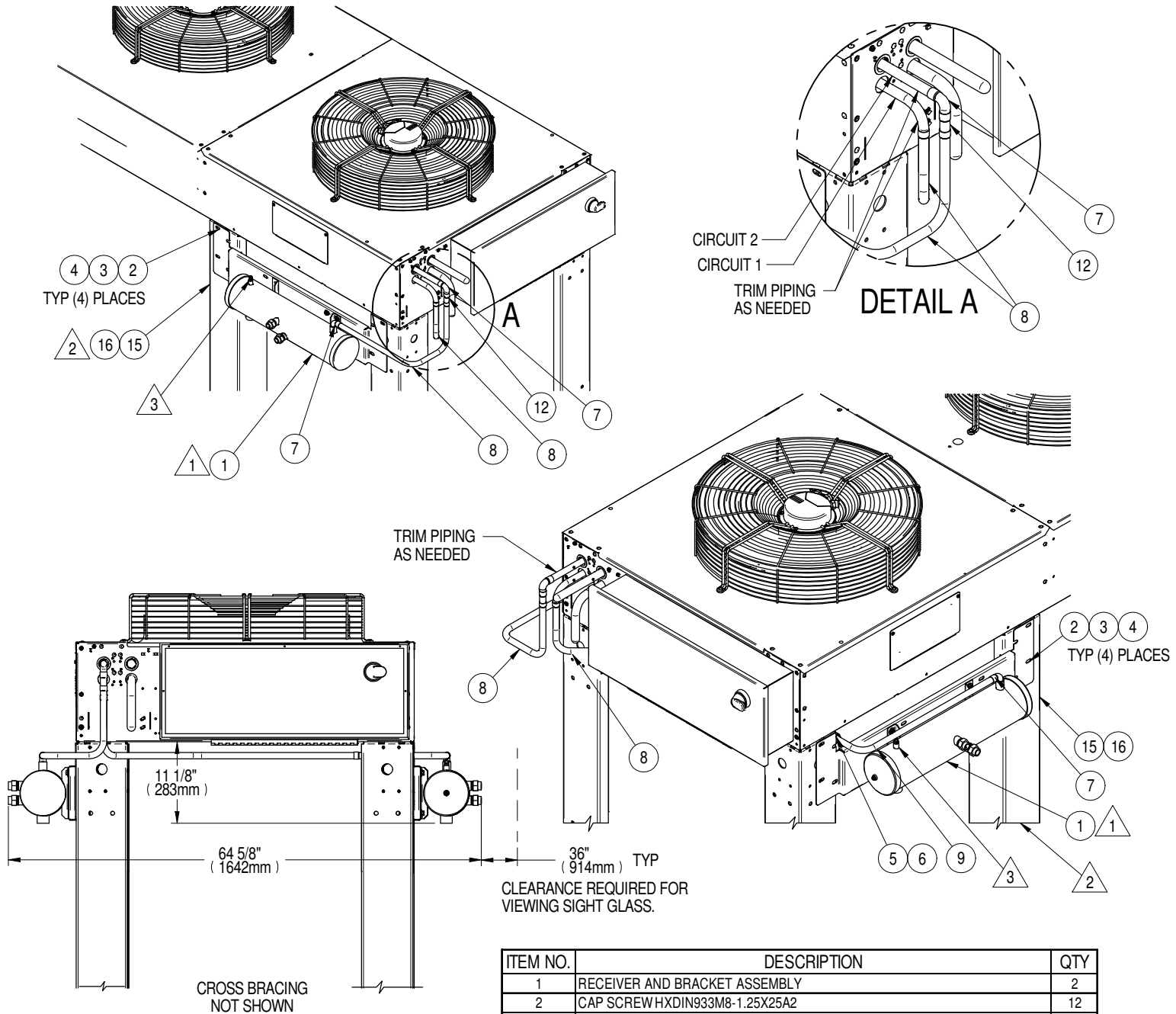

NOTES

- 1. SMALL RECEIVER SHOWN. ACTUAL RECEIVER SIZE MAY VARY.
- 2. RECEIVER LEG IS SAME HEIGHT AS OTHER LEGS AND NEEDS TO BE ANCHORED WITH THEM.
- 3. SCHRADER PORT FOR PROOF PRESSURE RELIEF ONLY & ACCESS NOT REQUIRED AFTER PIPING.

ITEM NO.	DESCRIPTION	QTY
1	RECEIVER AND BRACKET ASSEMBLY	2
2	CAP SCREW HXDIN933M8-1.25X25A2	12
3	FENDER WASHER DIN9021 M8X24 A2	20
4	LOCK NUT HEX NYL INSR M8	12
5	CLAMP OMEGA 7/8"	1
6	SCREW SD HWH YZ 10-16 X 5/8	2
7	90° ELBOW FTGXC 7/8" CU	3
8	COPPER FORMED TUBE 7/8"	2
9	COPPER FORMED TUBE 7/8"	1
12	COPPER TUBE 7/8" SWAGED	1
15	SUPPORT LEG	1
16	FASTENER ASSEMBLY: CAP SCREW, LOCK WASHER, FENDER WASHER	4

AIR COOLED PIPING SCHEMATIC CONDENSER ABOVE INDOOR UNIT

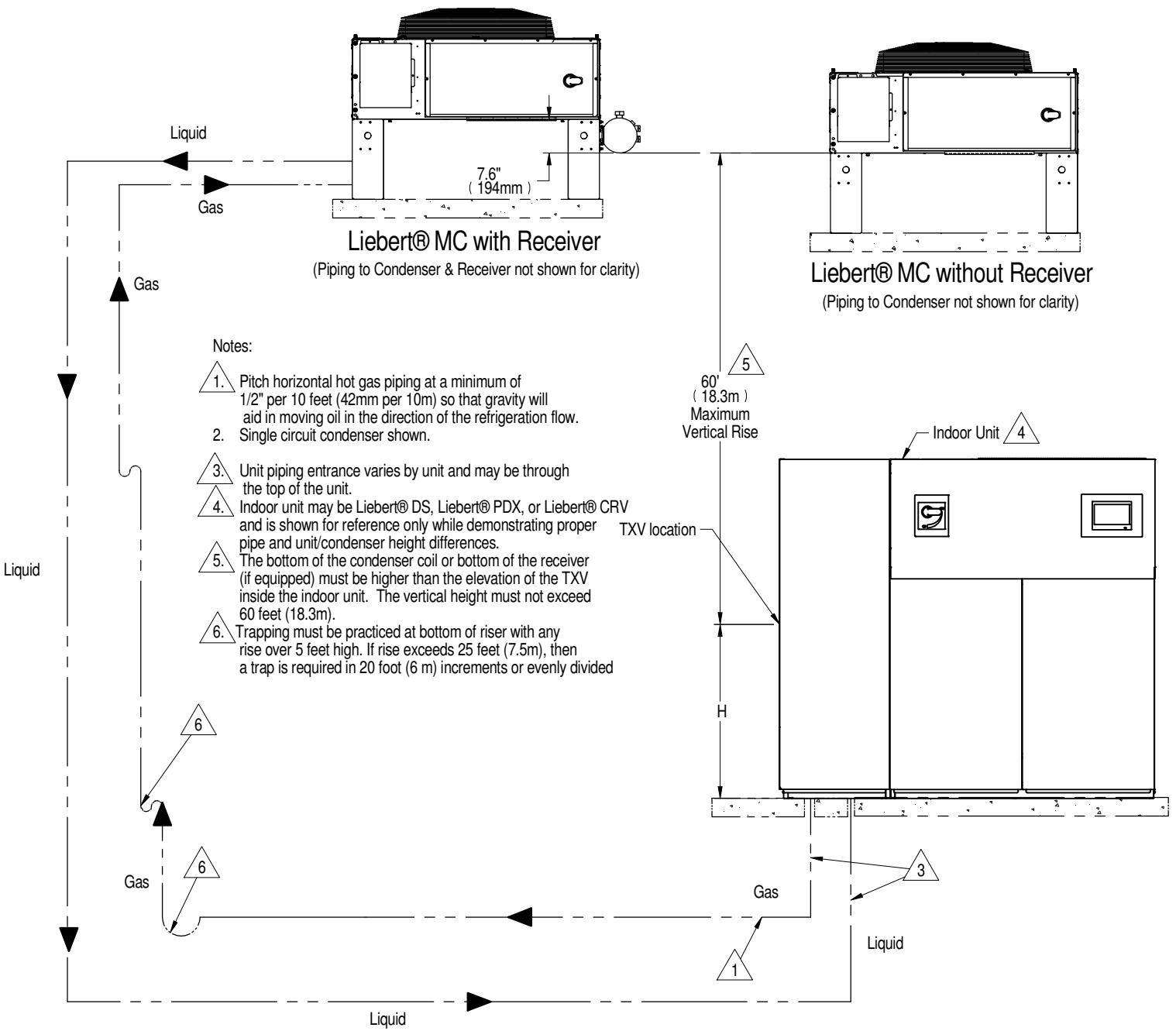

Notes:

- 1.** Pitch horizontal hot gas piping at a minimum of 1/2" per 10 feet (42mm per 10m) so that gravity will aid in moving oil in the direction of the refrigeration flow. Single circuit condenser shown.
- 2.** Unit piping entrance varies by unit and may be through the top of the unit.
- 3.** Indoor unit may be Liebert® DS, Liebert® PDX, or Liebert® CRV and is shown for reference only while demonstrating proper pipe and unit/condenser height differences.
- 4.** The bottom of the condenser coil or bottom of the receiver (if equipped) must be higher than the elevation of the TXV inside the indoor unit. The vertical height must not exceed 60 feet (18.3m).
- 5.** Trapping must be practiced at bottom of riser with any rise over 5 feet high. If rise exceeds 25 feet (7.5m), then a trap is required in 20 foot (6 m) increments or evenly divided

Internal TXV Height	H in. (mm)
Liebert® PDX Downflow	44 (1118)
Liebert® PDX Upflow	20 (508)
Liebert® DS	43 (1092)
Liebert® CRV - CR019	45 (1143)
Liebert® CRV - CR020/CR035	27 (686)

AIR COOLED PIPING SCHEMATIC CONDENSER AND INDOOR UNIT AT SAME LEVEL

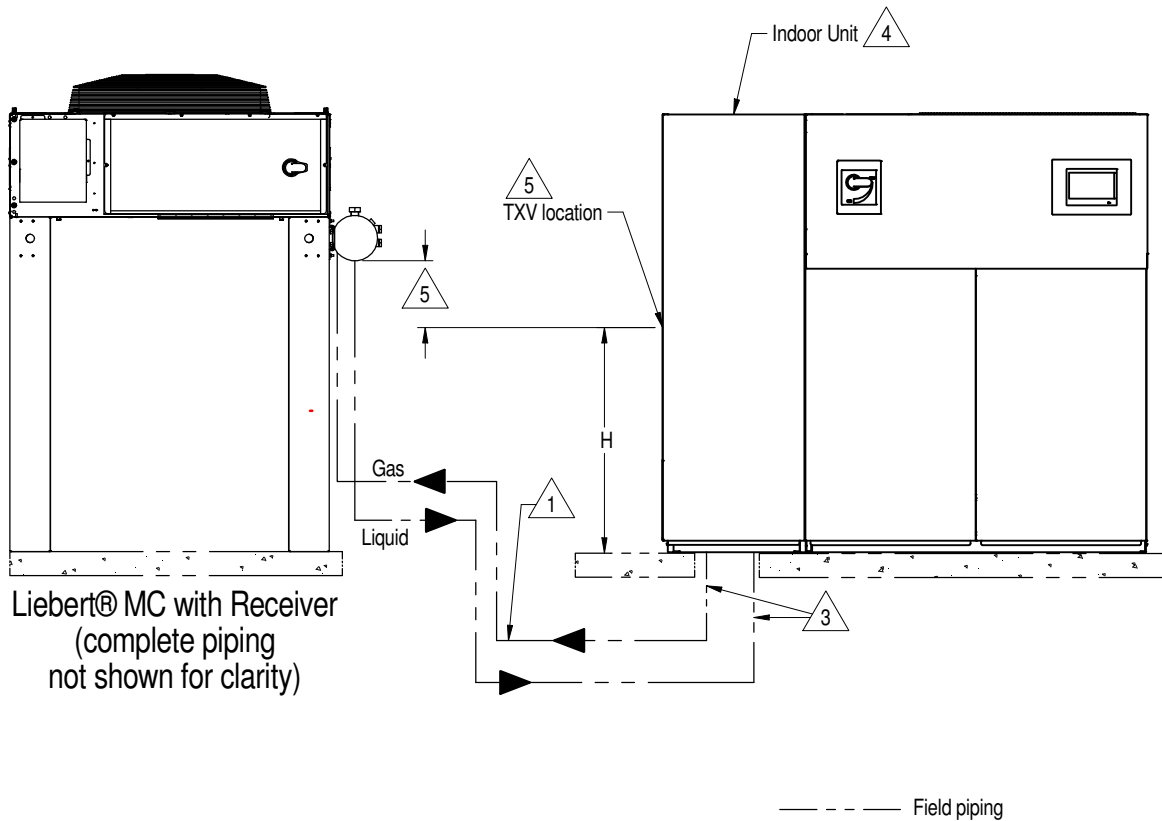

Liebert® MC with Receiver
(complete piping
not shown for clarity)

Notes:

1. Pitch horizontal hot gas piping at a minimum of 1/2" per 10 feet (42mm per 10m) so that gravity will aid in moving oil in the direction of the refrigeration flow.
2. Single circuit condenser shown.
3. Unit piping entrance varies by unit and may be through the top of the unit.
4. Indoor unit may be Liebert® DS, Liebert® PDX, or Liebert® CRV and is shown for reference only.
5. The bottom of the receiver must be higher than the elevation of the TXV inside the indoor unit, otherwise extended legs or a field piped subcooler needs to be utilized. Contact your Vertiv sales representative for additional information.

Internal TXV Height	H in. (mm)
Liebert® PDX Downflow	44 (1118)
Liebert® PDX Upflow	20 (508)
Liebert® DS	43 (1092)
Liebert® CRV - CR019	45 (1143)
Liebert® CRV - CR020/CR035	27 (686)

AIR COOLED PIPING SCHEMATIC CONDENSER AND INDOOR UNIT AT SAME LEVEL

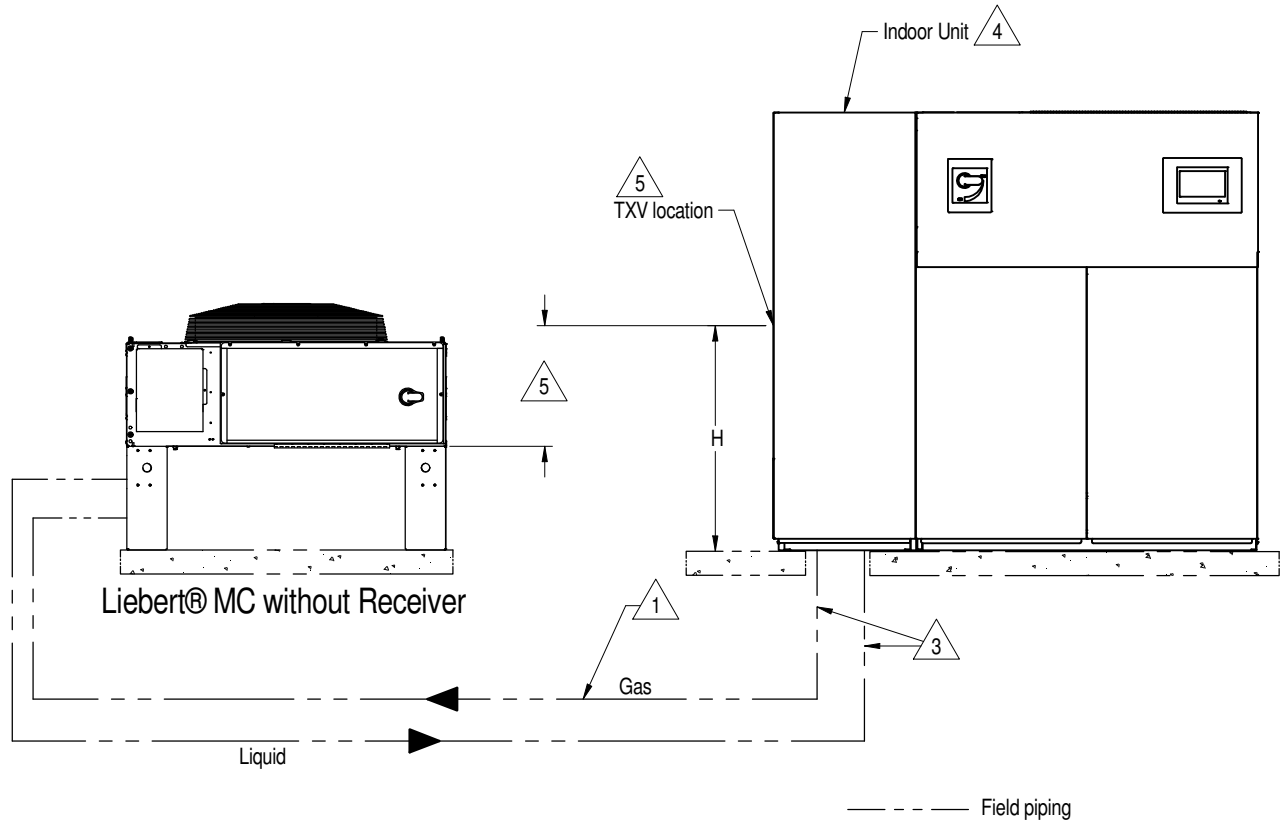

Notes:

1. Pitch horizontal hot gas piping at a minimum of 1/2" per 10 feet (42mm per 10m) so that gravity will aid in moving oil in the direction of the refrigeration flow.
2. Single circuit condenser shown.
3. Unit piping entrance varies by unit and may be through the top of the unit.
4. Indoor unit may be Liebert® DS, Liebert® PDX, or Liebert® CRV and is shown for reference only.
5. The bottom of the coil must be less than 15' (4.6m) below the elevation of the TXV inside the indoor unit.
Contact your Vertiv sales representative for additional information.

Internal TXV Height	H in. (mm)
Liebert® PDX Downflow	44 (1118)
Liebert® PDX Upflow	20 (508)
Liebert® DS	43 (1092)
Liebert® CRV - CR019	45 (1143)
Liebert® CRV - CR020/CR035	27 (686)

AIR COOLED PIPING SCHEMATIC CONDENSER BELOW INDOOR UNIT

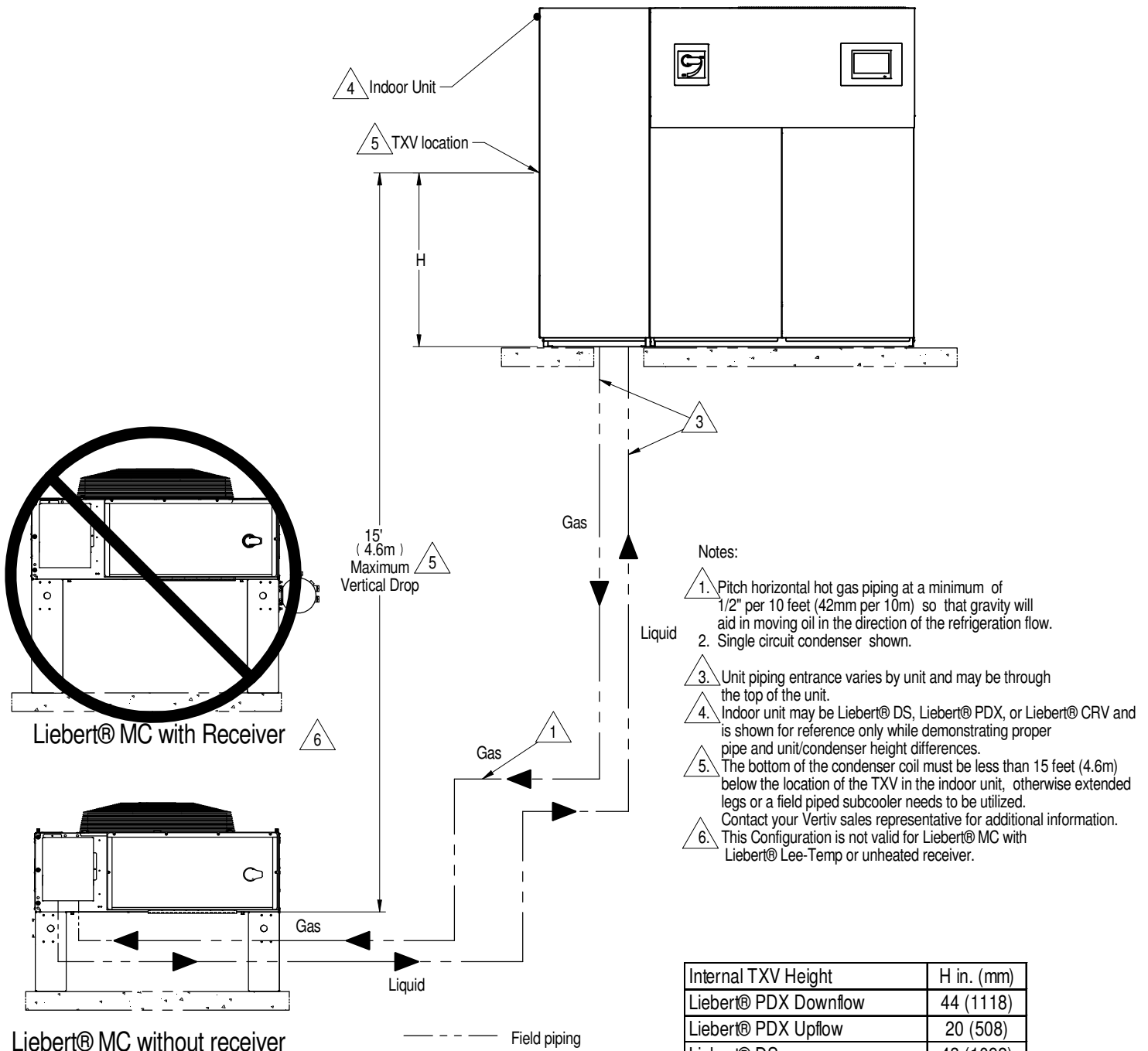

Internal TXV Height	H in. (mm)
Liebert® PDX Downflow	44 (1118)
Liebert® PDX Upflow	20 (508)
Liebert® DS	43 (1092)
Liebert® CRV - CR019	45 (1143)
Liebert® CRV - CR020/CR035	27 (686)



LIEBERT® PDX w/EEV

AIR COOLED PIPING SCHEMATIC LIEBERT® MC WITH RECEIVER ABOVE UNIT

Notes:

1. The outlet of the required receiver must be higher than the elevation of the EEV inside the indoor unit.
2. Unit must be trapped at bottom of riser with any rise over 5 feet (1.5m) high. If rise exceeds 25 feet (7.5m), then a trap is required in 20 foot (6.1m) increments or evenly divided.
3. Pitch horizontal hot gas piping at a minimum of 1/2 inch per 10 feet (42 mm per 10m) so that gravity will aid in moving oil in the direction of the refrigeration flow.
4. Condenser legs are available in lengths of 18 inch (457mm), 36 inch (914mm), 48 inch (1219mm), or 60 inch (1524mm) to adjust the elevation of the base of the receiver.
5. Unit piping entrance varies by unit and may be through the top of the unit

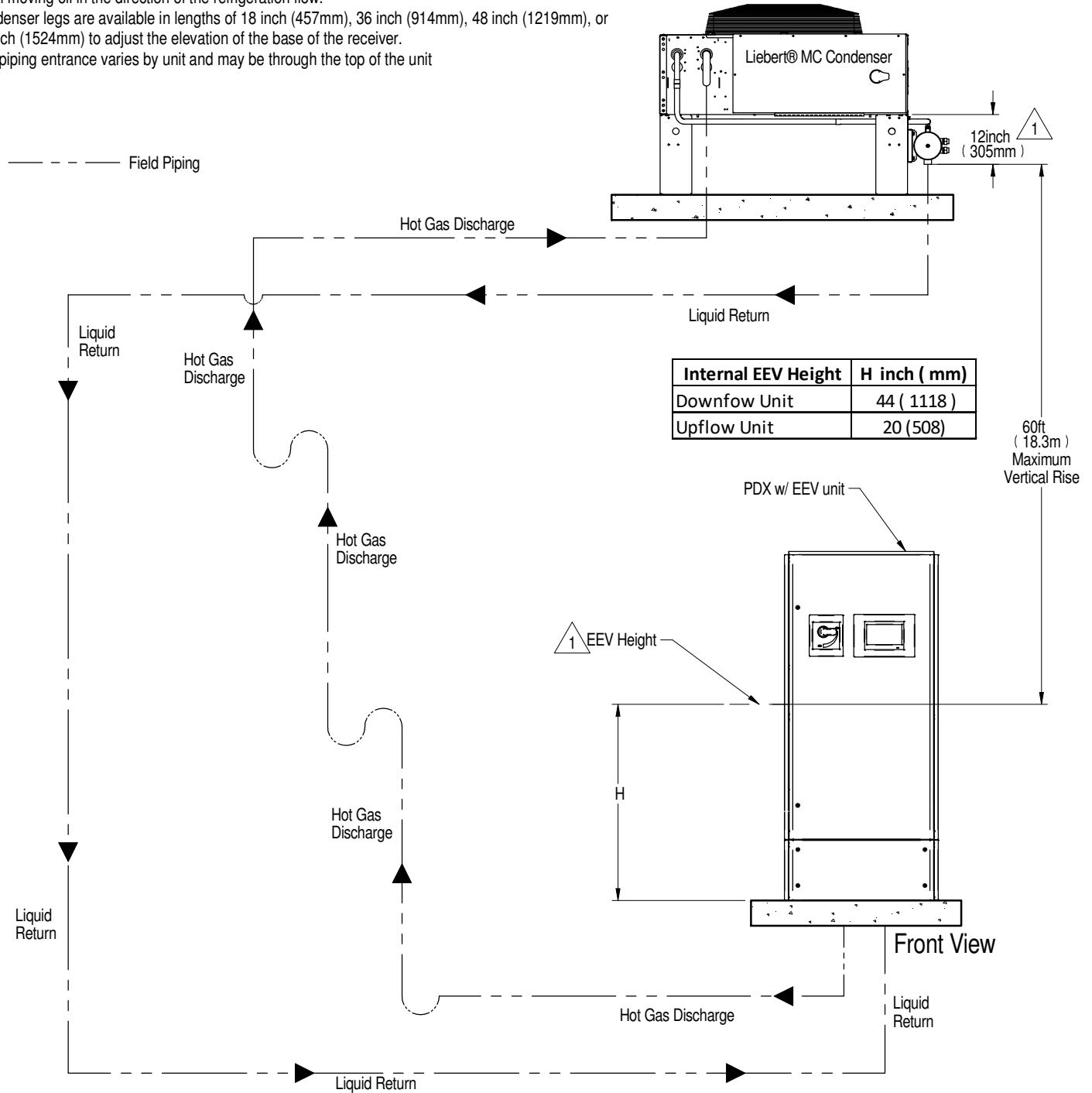

AIR COOLED PIPING SCHEMATIC

LIEBERT® MC WITH RECEIVER MOUNTED AND UNIT AT SIMILAR LEVEL

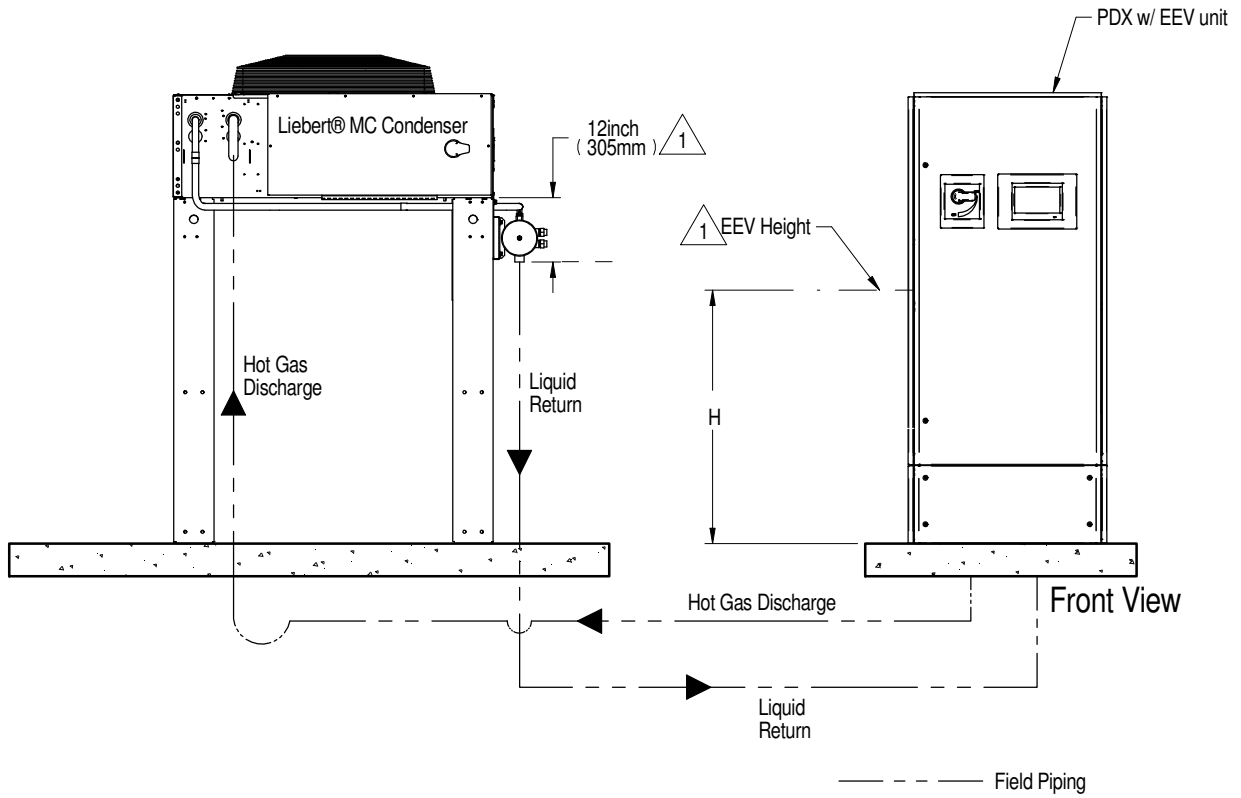

Internal EEV Height	H inch (mm)
Downfow Unit	44 (1118)
Upfow Unit	20 (508)

Notes:

1. The outlet of the required receiver must be higher than the elevation of the EEV inside the indoor unit.
2. Unit must be trapped at bottom of riser with any rise over 5 feet (1.5m) high. If rise exceeds 25 feet (7.5m), then a trap is required in 20 foot (6.1m) increments or evenly divided.
3. Pitch horizontal hot gas piping at a minimum of ½ inch per 10 feet (42mm per 10m) so that gravity will aid in moving oil in the direction of the refrigeration flow.
4. Condenser legs are available in lengths of 18 inch (457mm), 36 inch (914mm), 48 inch (1219mm), or 60 inch (1524mm) to adjust the elevation of the base of the receiver.
5. Unit piping entrance varies by unit and may be through the top of the unit

AIR COOLED PIPING SCHEMATIC LIEBERT® MC WITH RECEIVERS MOUNTED ABOVE DA080-165

1-3/8 inch minimum diameter Liquid line.
DO NOT TRAP LINE! Slope 2 inch per
10 ft (167mm per 10 meter) down
towards Liebert® EconoPhase unit.
Single Circuit system shown for clarity.

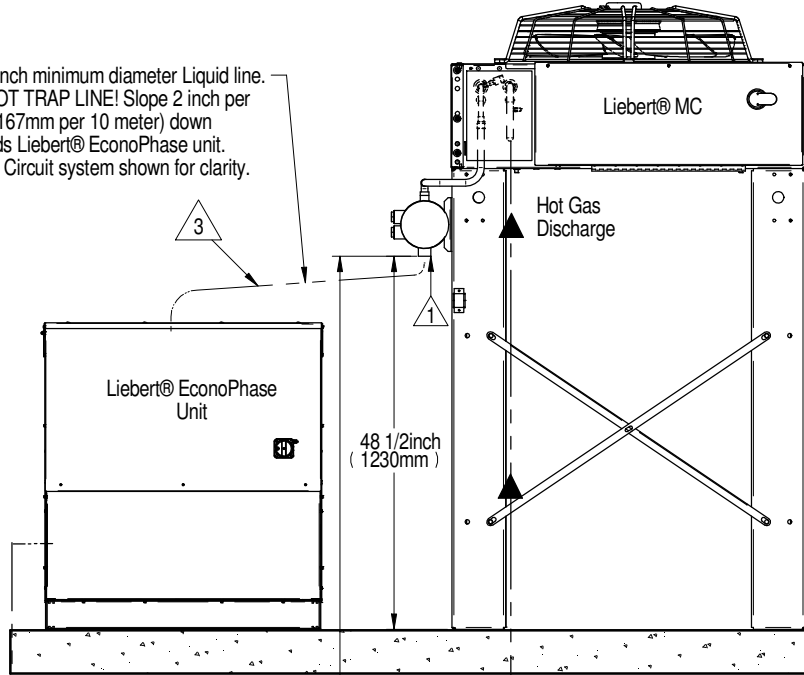

Notes:

1. The outlet of the receiver must be higher than the elevation of the EEV inside the indoor unit. The vertical height must not exceed 60 ft (18.3m).
2. For proper pump function, a minimum elevation difference of 60 inch (1524 mm) must be maintained between the bottom of condenser coil to the bottom of Liebert® EconoPhase unit.
3. The maximum equivalent piping between the Liebert® MC and Liebert® EconoPhase unit is 25 ft (7.6 m). Liebert® EconoPhase unit must be mounted outdoors for proper operation.
4. Unit must be trapped at bottom of riser with any rise over 5 feet (1.5m) high. If rise exceeds 25 feet (7.5m), then a trap is required in 20 foot (6.1m) increments or evenly divided.
5. Pitch horizontal hot gas piping at a minimum of 1/2" per 10 feet (42 mm per 10m) so that gravity will aid in moving oil in the direction of the refrigeration flow.
6. Unit piping entrance varies by unit and may be through the top of the unit.
7. All indoor field refrigerant piping must be insulated, 1/2" minimum thickness. All outdoor field refrigeration piping does not need to be insulated. The installing contractor is responsible for the insulating, securing, protecting and the proper installation of all field refrigerant piping, observing the details outlined by the Engineer of Record.
8. Consult factory for any exceptions to the above guidelines.

Internal EEV Height	H inch (mm)
DA080-165	43 (1092)

----- Field Piping

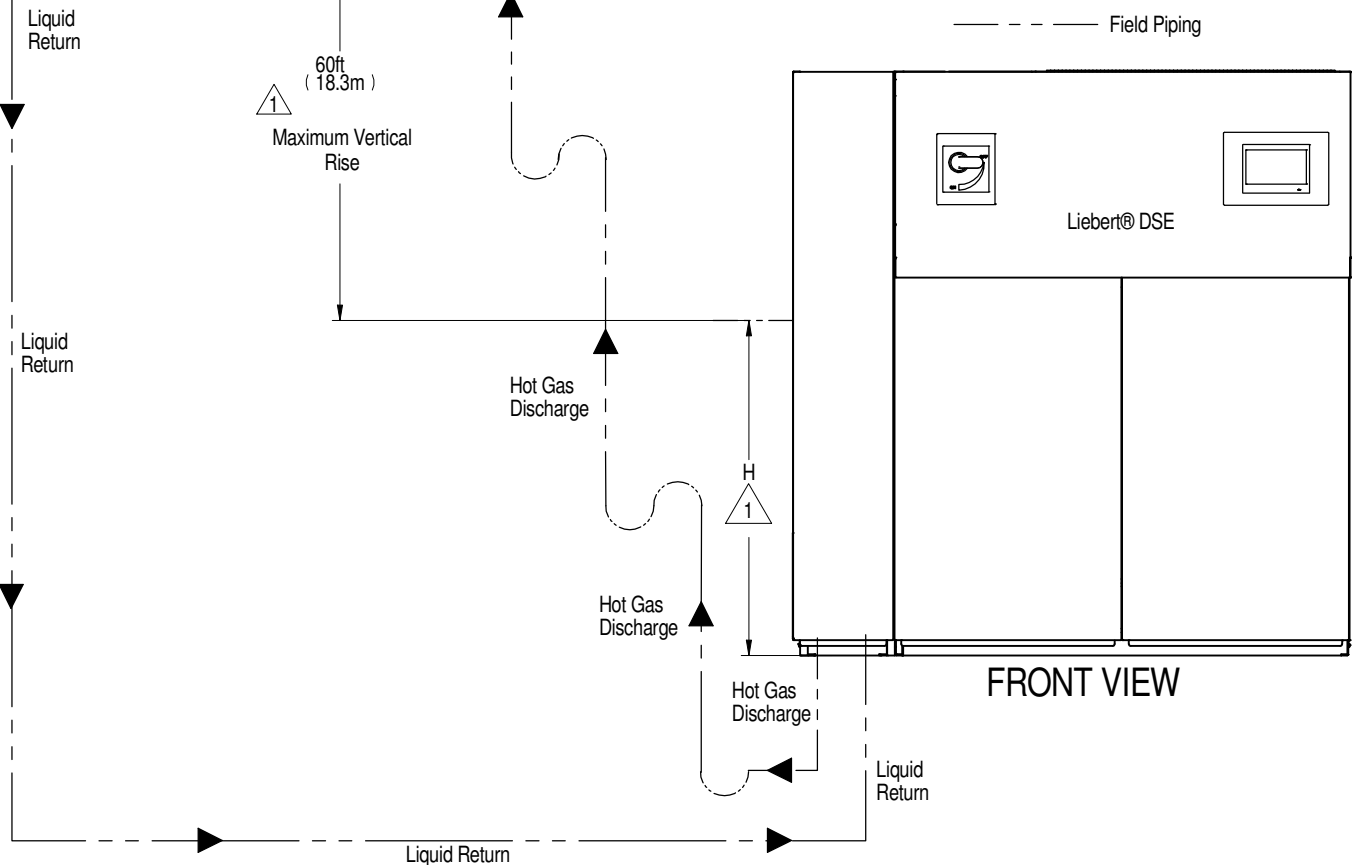

AIR COOLED PIPING SCHEMATIC

DA080-165 AND LIEBERT® MC WITH RECEIVERS AT SIMILAR LEVELS

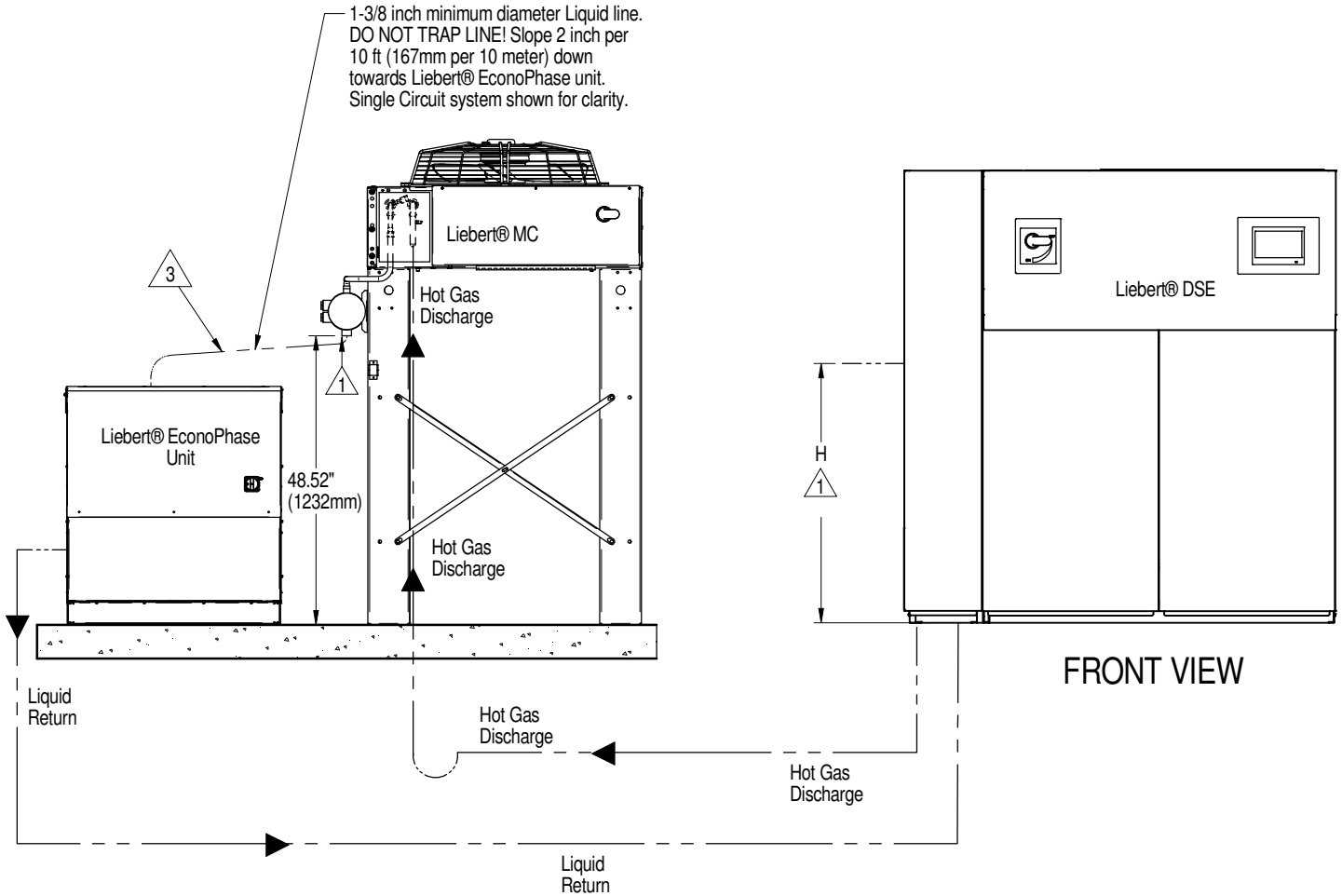

Internal EEV Height	H inch (mm)
DA080-165	43 (1092)

Field Piping

Notes:

1. The outlet of the receiver must be higher than the elevation of the EEV inside the indoor unit.
2. For proper pump function, a minimum elevation difference of 60 inch (1524 mm) must be maintained between the bottom of condenser coil to the bottom of Liebert® EconoPhase unit.
3. The maximum equivalent piping between the Liebert® MC and Liebert® EconoPhase unit is 25 ft (7.6 m). Liebert® EconoPhase unit must be mounted outdoors for proper operation.
4. Unit must be trapped at bottom of riser with any rise over 5 feet (1.5m) high. If rise exceeds 25 feet (7.5m), then a trap is required in 20 foot (6.1m) increments or evenly divided.
5. Pitch horizontal hot gas piping at a minimum of 1/2" per 10 feet (42 mm per 10m) so that gravity will aid in moving oil in the direction of the refrigeration flow.
6. Unit piping entrance varies by unit and may be through the top of the unit.
7. All indoor field refrigerant piping must be insulated, 1/2" minimum thickness. All outdoor field refrigeration piping does not need to be insulated. The installing contractor is responsible for the insulating, securing, protecting and the proper installation of all field refrigerant piping, observing the details outlined by the Engineer of Record.
8. Consult factory for any exceptions to the above guidelines.

TYPICAL PIPING SCHEMATIC FOR AIR-COOLED DX SYSTEMS

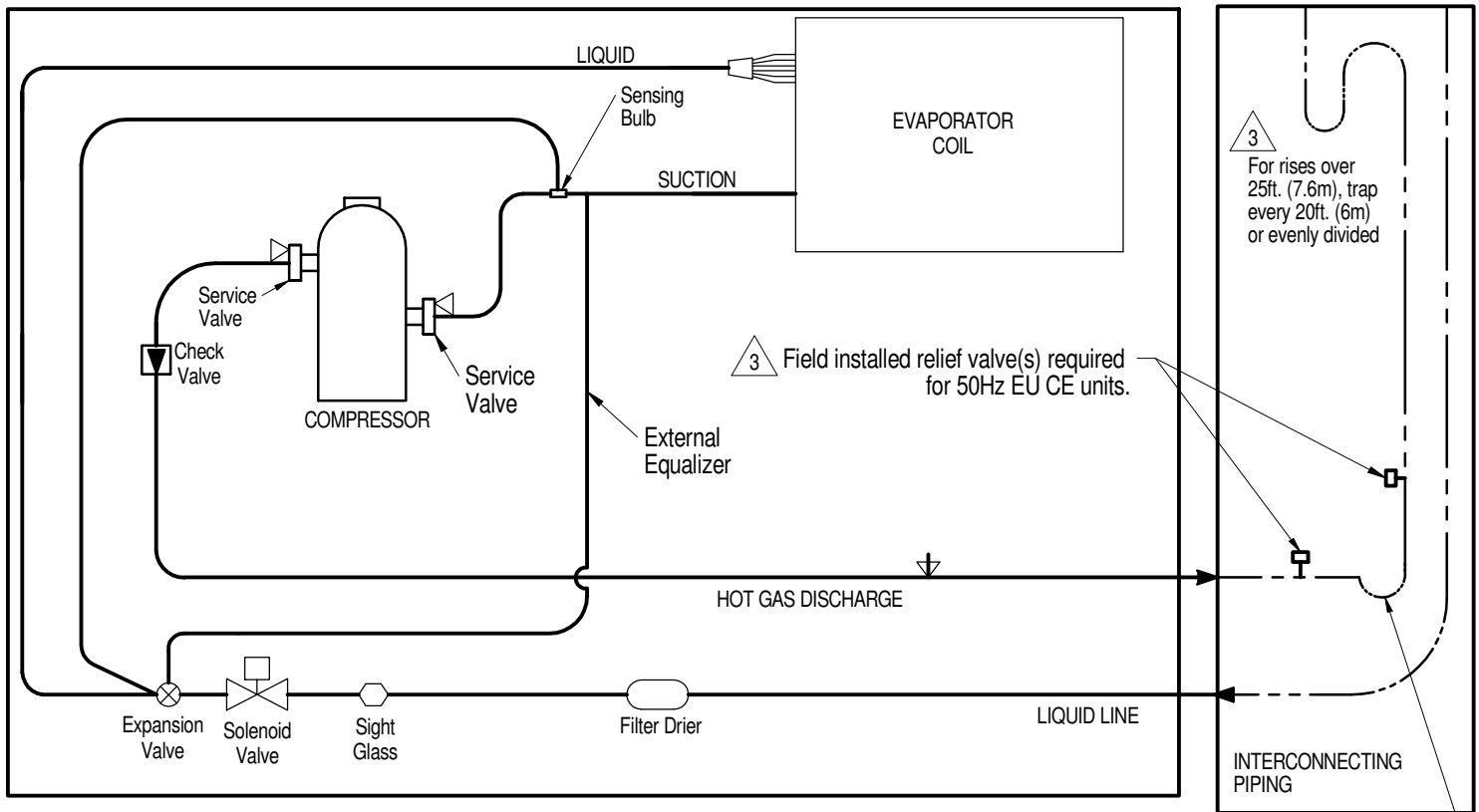
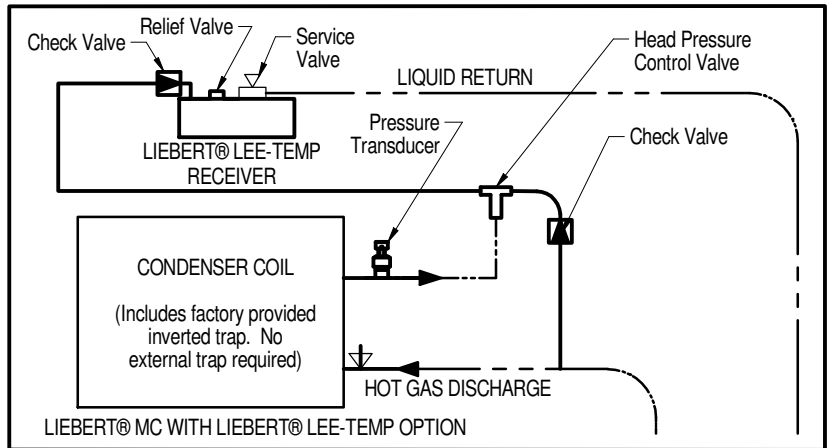
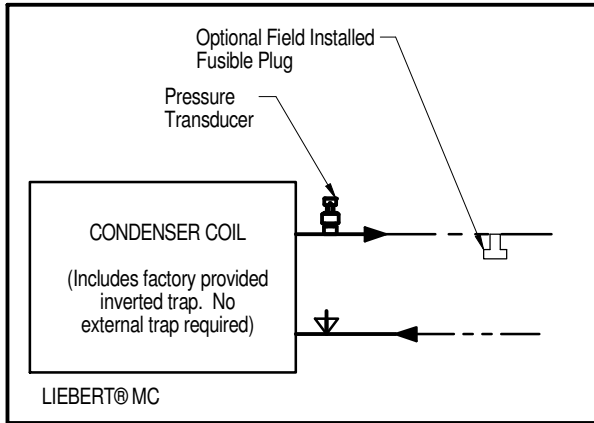

- FACTORY REFRIGERANT PIPING
- - - - - FIELD PIPING
- ▽ SERVICE/SCHRADER (ACCESS) CONNECTION NO VALVE CORE
- ▽ SERVICE/SCHRADER (ACCESS) CONNECTION WITH VALVE CORE

Notes:

1. Single refrigeration circuit shown for clarity.
2. Schematic representation shown. Do not use for specific connection locations.
3. Components are not supplied by Vertiv, but are required for proper operation and maintenance.
4. Traps must be installed and horizontal lines pitched to ensure proper oil return and to reduce liquid floodback to compressor. Pitch horizontal hot gas piping at a minimum of 1/2" per 10 feet (42mm per 10m) so that gravity will aid in moving oil in the direction of the refrigeration flow.
5. Do not isolate any refrigeration circuits from over pressurization protection.

GENERAL ARRANGEMENT DIAGRAM 600mm (24in.) AIR COOLED W/ LIEBERT® MC MODELS

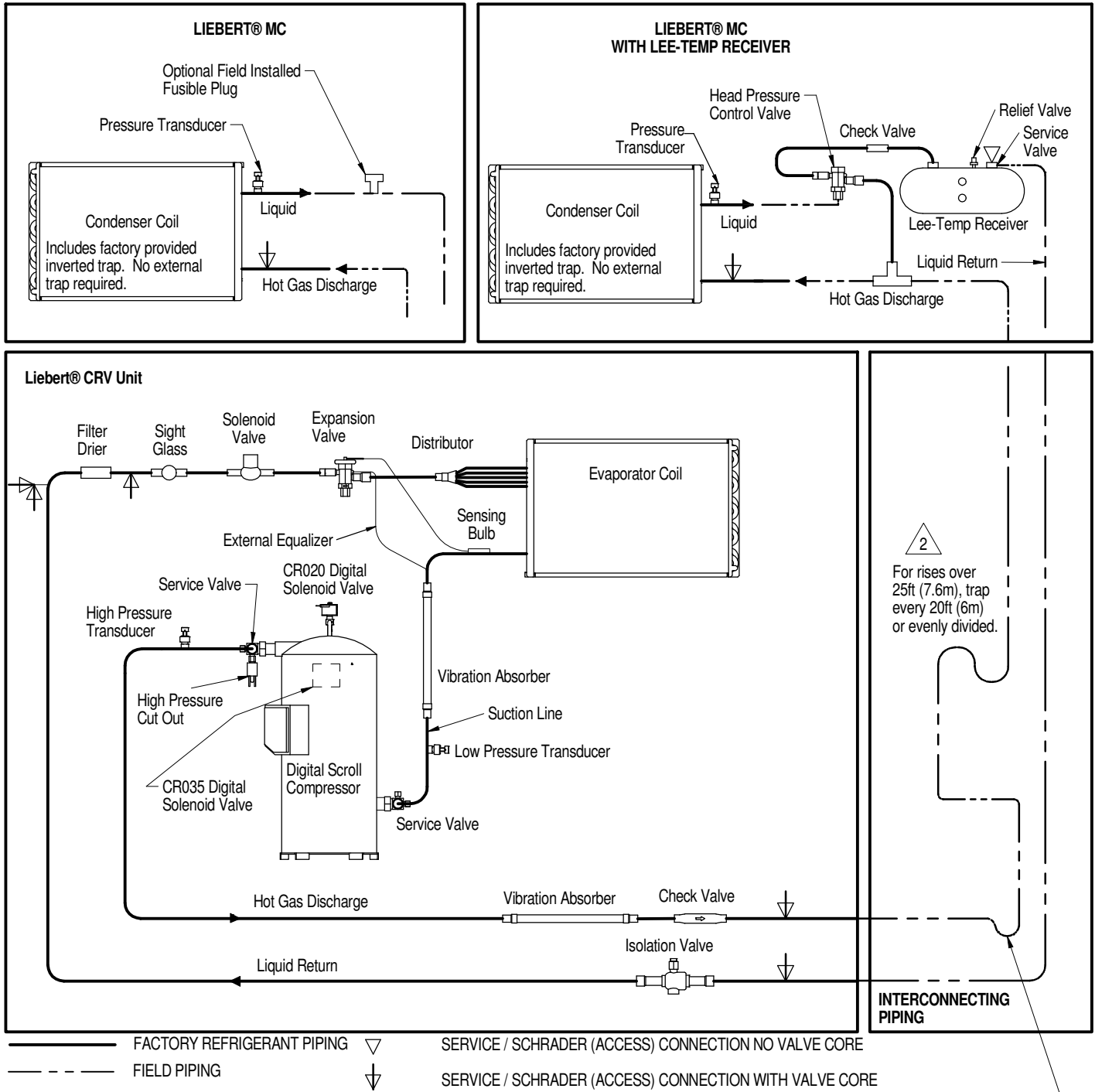

Notes:

- Schematic representation shown. Do not use for specific connection locations.
- Components are not supplied by Vertiv™, but are required for proper circuit operation and maintenance. Liebert® CRV has an internal trap at the base of the unit. For field piping the discharge line vertical rise starts at the base of the unit and not the top of the unit.
- Do not isolate any refrigerant circuit from over pressurization protection.
- Traps must be installed and horizontal lines pitched to ensure proper oil return and to reduce liquid floodback to compressor. Pitch horizontal hot gas piping at a minimum of 1/2" per 10 feet (42mm per 10m) so that gravity will aid in moving oil in the direction of the refrigeration flow.

GENERAL ARRANGEMENT DIAGRAM 300mm (12in.) AIR COOLED W/ LIEBERT® MC MODELS

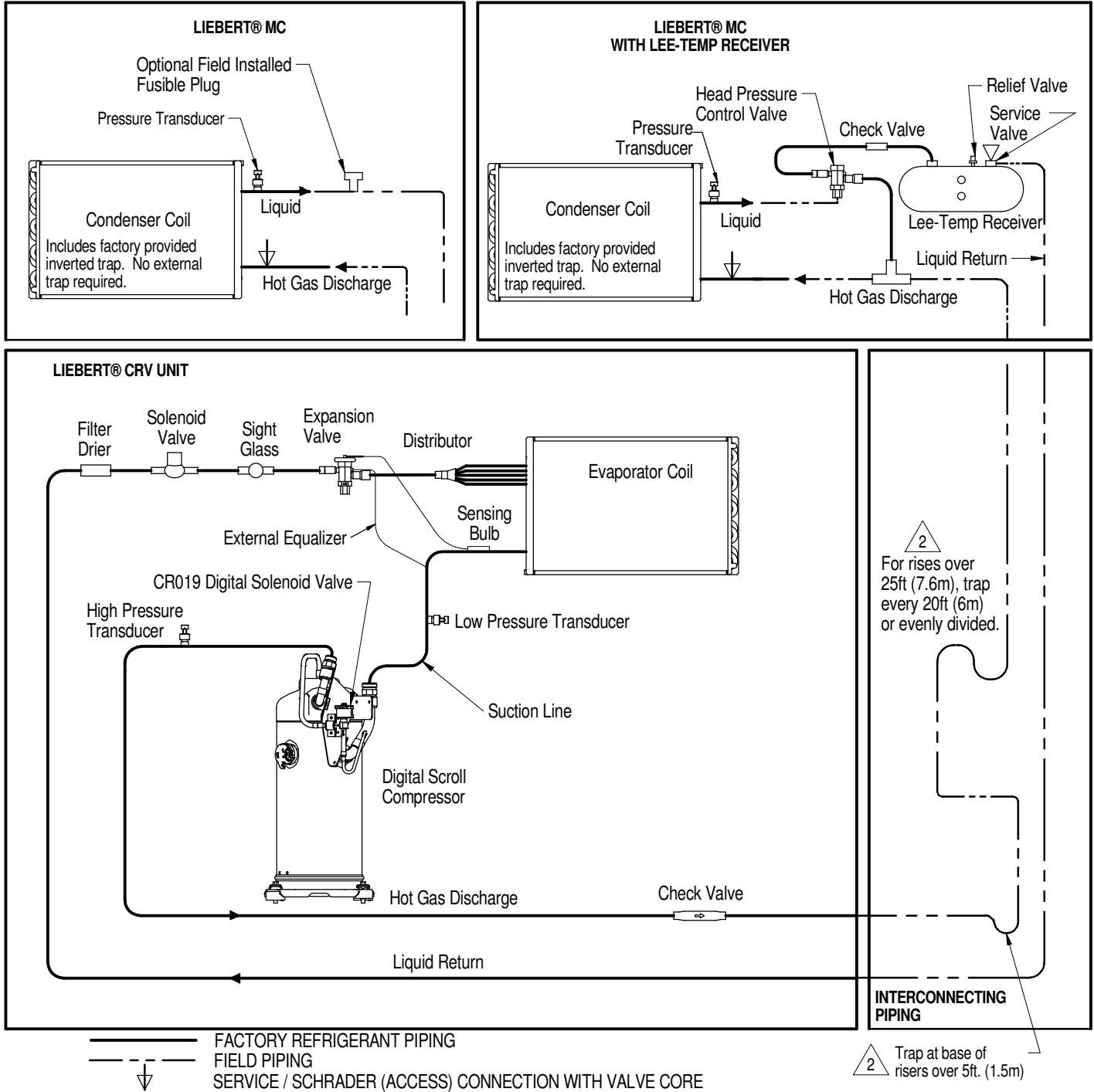

Notes:

1. Schematic representation shown. Do not use for specific connection locations.

2. Components are not supplied by Vertiv™, but are required for proper circuit operation and maintenance. Liebert® CRV has an internal trap at the base of the unit. For field piping, the discharge line vertical rise starts at the base of the unit and not at the top.

3. Do not isolate any refrigerant circuit from over pressurization protection.

4. Traps must be installed and horizontal lines pitched to ensure proper oil return and to reduce liquid floodback to compressor. Pitch horizontal hot gas piping at a minimum of 1/2" per 10 feet (42mm per 10m) so that gravity will aid in moving oil in the direction of the refrigeration flow.

PIPING SCHEMATIC W/ LIEBERT® MC AIR COOLED SCROLL OR DIGITAL SCROLL COMPRESSOR MODELS

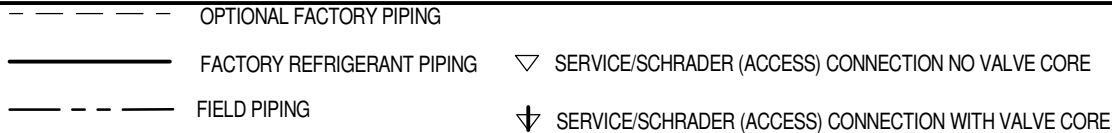
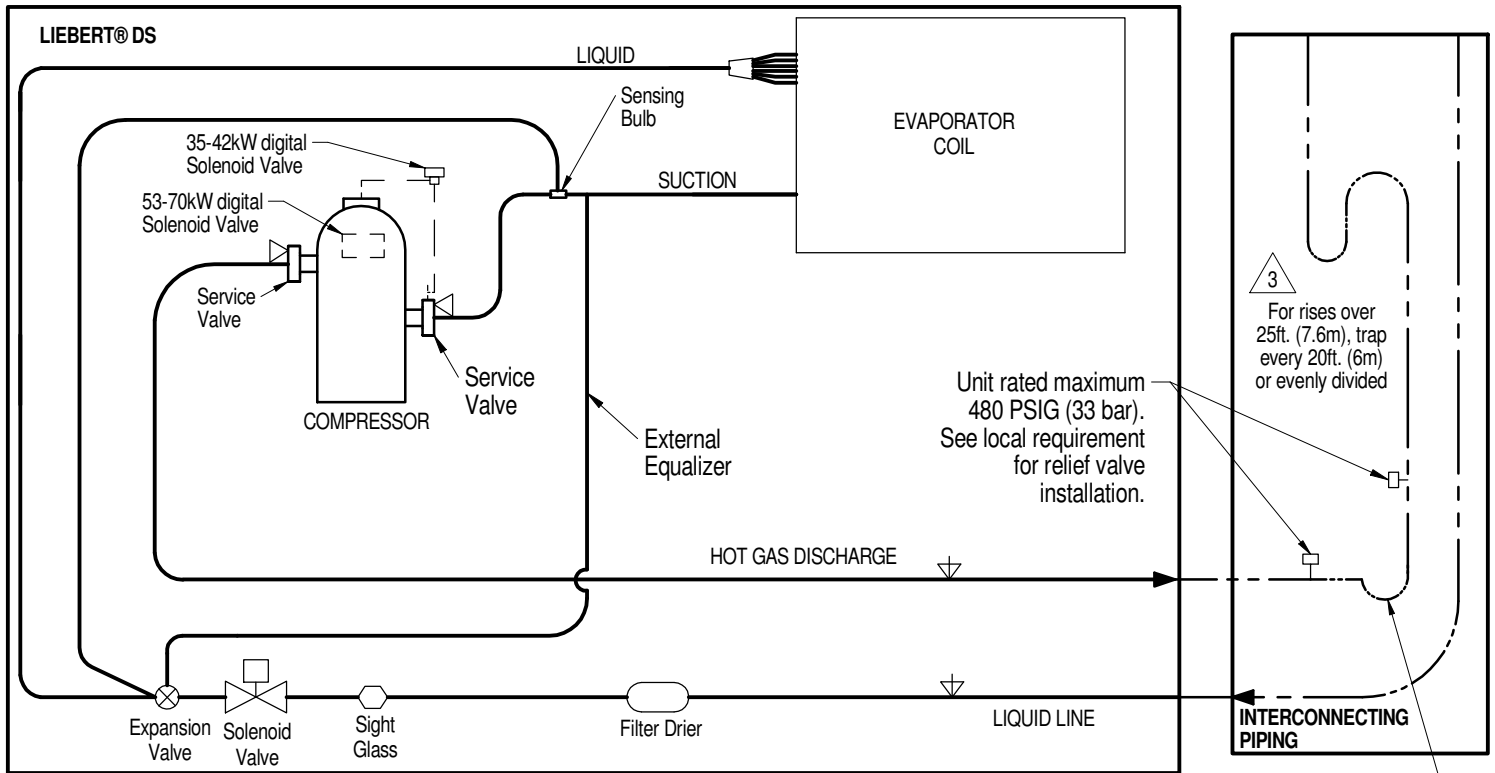
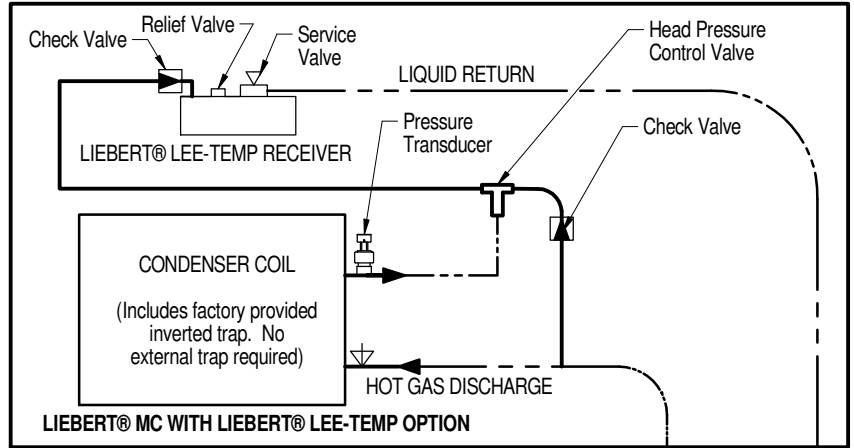
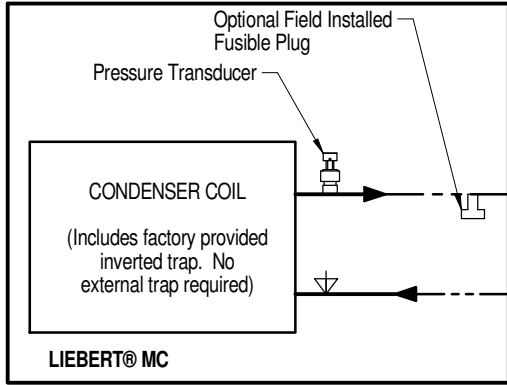

Notes:

1. Single refrigeration circuit shown for clarity.
2. Schematic representation shown. Do not use for specific connection locations.
3. Components are not supplied by Vertiv, but are required for proper operation and maintenance.
4. Traps must be installed and horizontal lines pitched to ensure proper oil return and to reduce liquid floodback to compressor. Pitch horizontal hot gas piping at a minimum of 1/2" per 10 feet (42mm per 10m) so that gravity will aid in moving oil in the direction of the refrigeration flow.
5. Do not isolate any refrigerant circuits from over pressurization protection.

PIPING SCHEMATIC W/ LIEBERT® MC AIR COOLED DS077-105kW SEMI-HERMETIC COMPRESSOR MODELS

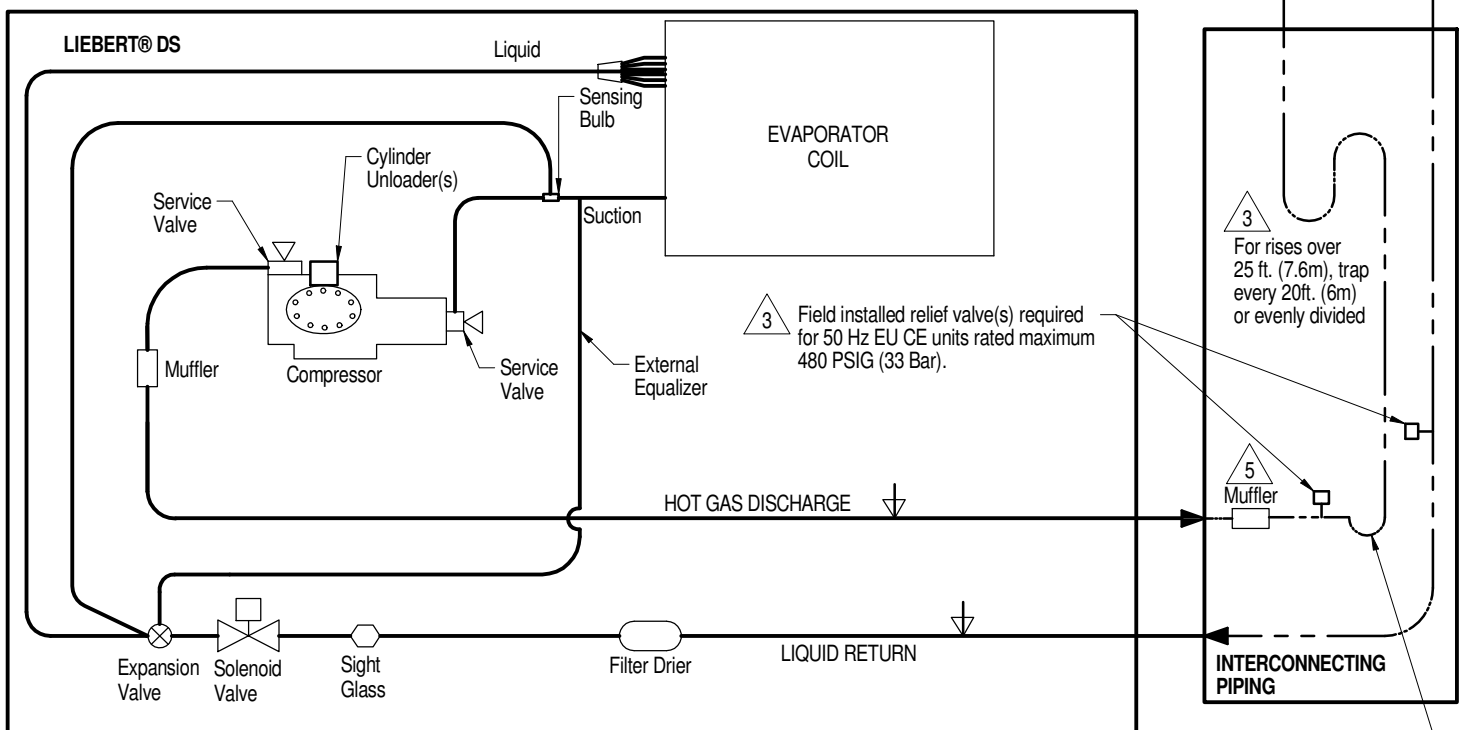
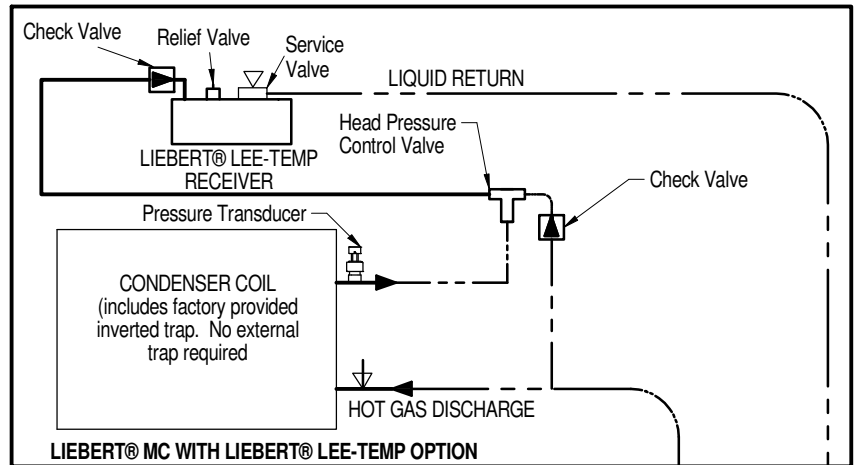
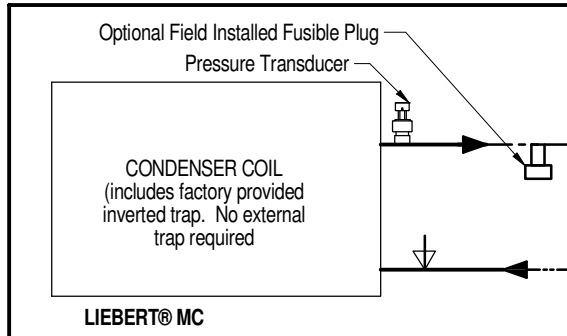

- FACTORY REFRIGERANT PIPING
- - - FIELD PIPING
- ▽ SERVICE/SCHRADER (ACCESS) CONNECTION NO VALVE CORE
- ▽ SERVICE/SCHRADER (ACCESS) CONNECTION WITH VALVE CORE

Notes:

1. Single refrigeration circuit shown for clarity.
2. Schematic representation shown. Do not use for specific connection locations.
3. Components are not supplied by Vertiv, but are required for proper operation and maintenance.
4. Traps must be installed and horizontal lines pitched to ensure proper oil return and to reduce liquid floodback to compressor. Pitch horizontal hot gas piping at a minimum of 1/2" per 10 feet (42mm per 10m) so that gravity will aid in moving oil in the direction of the refrigeration flow.
5. Component supplied by Vertiv and must be field installed.
6. Do not isolate any refrigerant circuits from over pressurization protection.

PIPING SCHEMATIC

DA080 & DA085 MODELS W/ LIEBERT® MC WITH RECEIVERS

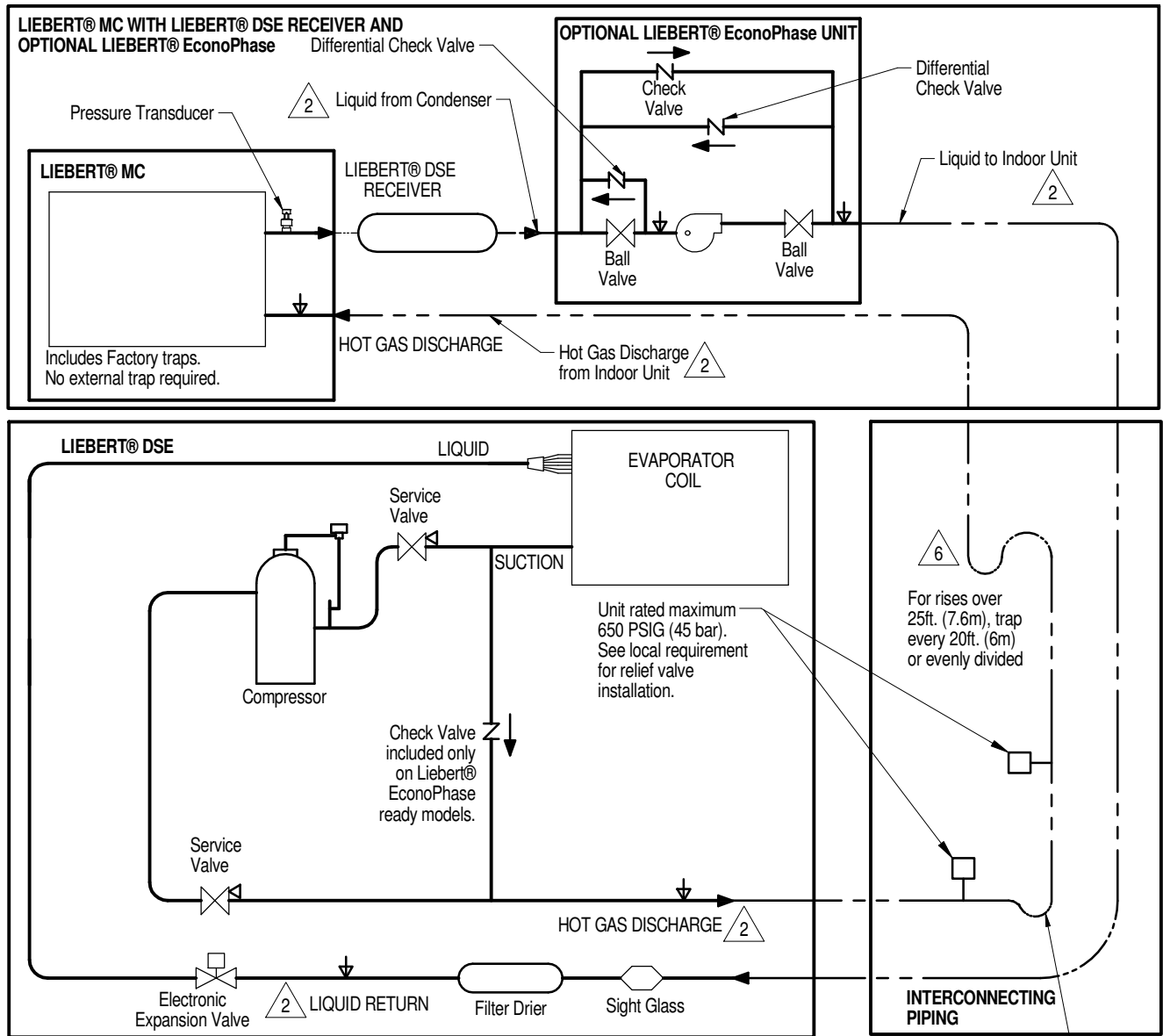

————— FACTORY REFRIGERANT PIPING
 - - - - - FIELD PIPING

▽ SERVICE/SCHRADER (ACCESS) CONNECTION, NO VALVE CORE.
 ▾ SERVICE/SCHRADER (ACCESS) CONNECTION, WITH VALVE CORE.

- Notes:
- Two refrigeration circuits provided on DA080 & DA085. Single refrigeration circuit shown for clarity.
 - Circuit 1 must be maintained between indoor unit, condenser and Liebert® EconoPhase unit. Circuit 2 must be maintained between indoor unit, condenser and Liebert® EconoPhase unit.
 - Schematic representation shown. Do not use for specific connection locations.
 - The outlet of the receiver must be higher than the elevation of the EEV inside the indoor unit. This vertical height must not exceed 60ft. (18.3m). Liebert® DSE Receiver required for systems with or without Liebert® EconoPhase unit.
 - All indoor field refrigerant piping must be insulated, 1/2" minimum thickness. All outdoor field refrigeration piping does not need to be insulated. The installing contractor is responsible for the insulating, securing, protecting and the proper installation of all field refrigerant piping, observing the details outlined by the Engineer of Record.
 - Components are not supplied by Vertiv but are required for proper circuit operation and maintenance.
 - Traps must be installed and horizontal lines pitched to ensure proper oil return and to reduce liquid flood back to compressor. Pitch horizontal hot gas piping at a minimum of 1/2" per 10 feet (42mm per 10m) so that gravity will aid in moving oil in the direction of refrigeration flow.
 - Do not isolate any refrigeration circuits from over pressurization protection.

PIPING SCHEMATIC DA125, DA150 & DA165 W/ LIEBERT® MC WITH RECEIVERS

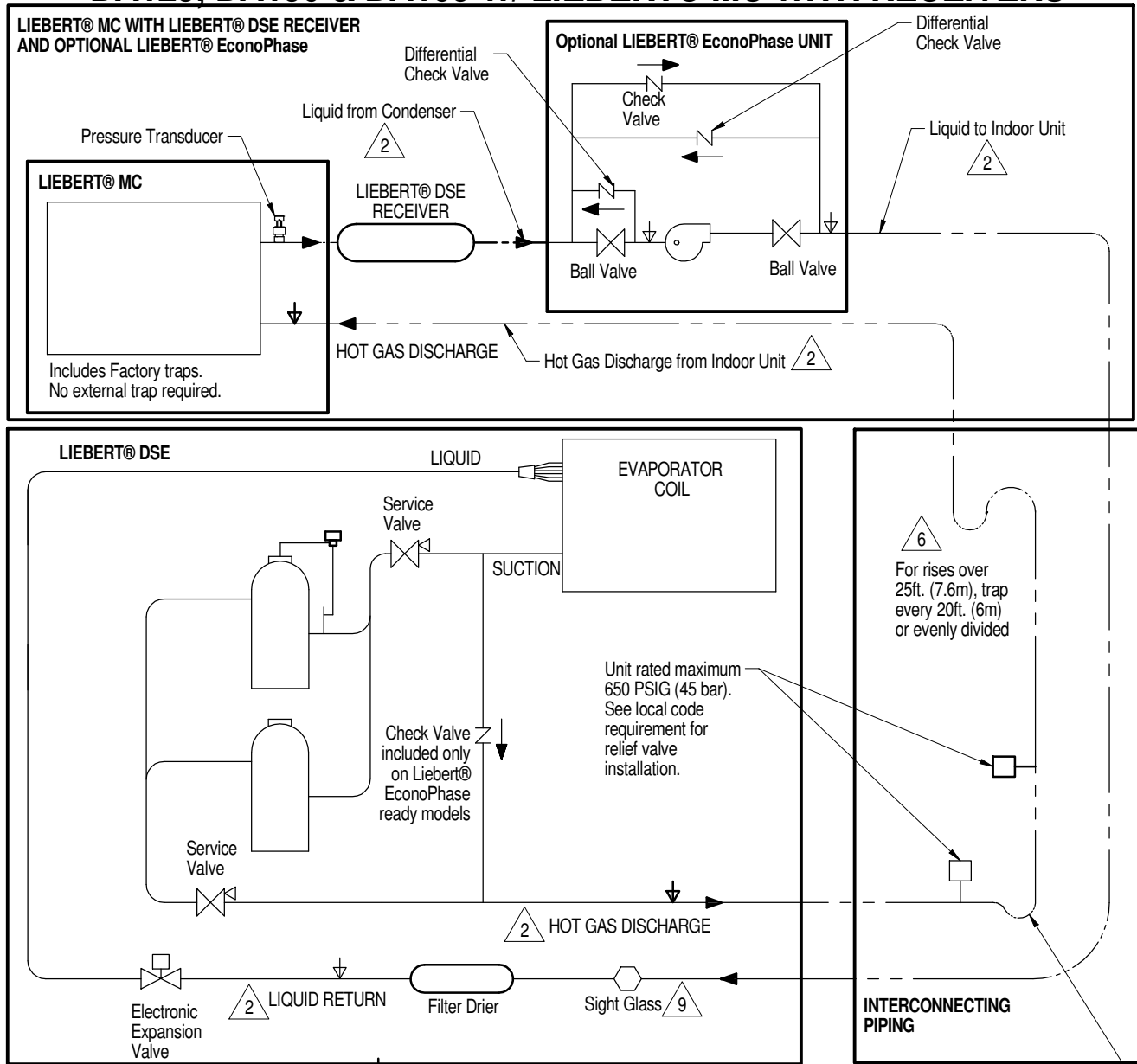

- Notes:
- Two refrigeration circuits provided. Single refrigeration circuit shown for clarity.
 - Circuit 1 must be maintained between indoor unit, condenser and Liebert® EconoPhase unit. Circuit 2 must be maintained between indoor unit, condenser and Liebert® EconoPhase unit.
 - Schematic representation shown. Do not use for specific connection locations.
 - The outlet of the receiver must be higher than the elevation of the EEV inside the indoor unit. This vertical height must not exceed 60ft. (18.3m). Liebert® DSE Receiver required for systems with or without Liebert® EconoPhase.
 - All indoor field refrigerant piping must be insulated, 1/2" minimum thickness. All outdoor field refrigeration piping does not need to be insulated. The installing contractor is responsible for the insulating, securing, protecting and the proper installation of all field refrigerant piping, observing the details outlined by the Engineer of Record.
 - Components are not supplied by Vertiv but are required for proper circuit operation and maintenance.
 - Traps must be installed and horizontal lines pitched to ensure proper oil return and to reduce liquid flood back to compressor. Pitch horizontal gas piping at a minimum of 1/2" per 10 feet (42mm per 10m) so that gravity will aid in moving oil in the direction of the refrigeration flow.
 - Do not isolate any refrigerant circuits from over pressurization protection.
 - Typical location for Sight Glass on DA150 and DA165. On DA125, Sight Glass is located between Filter Drier and Electronic Expansion Valve.

PIPING SCHEMATIC AIR COOLED MODELS WITH TXV

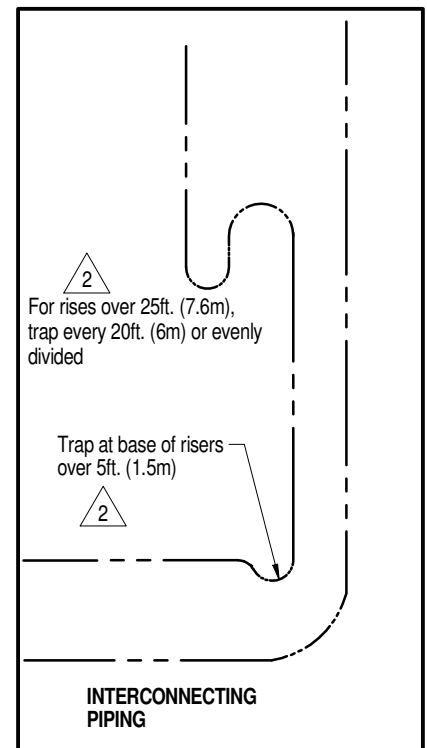
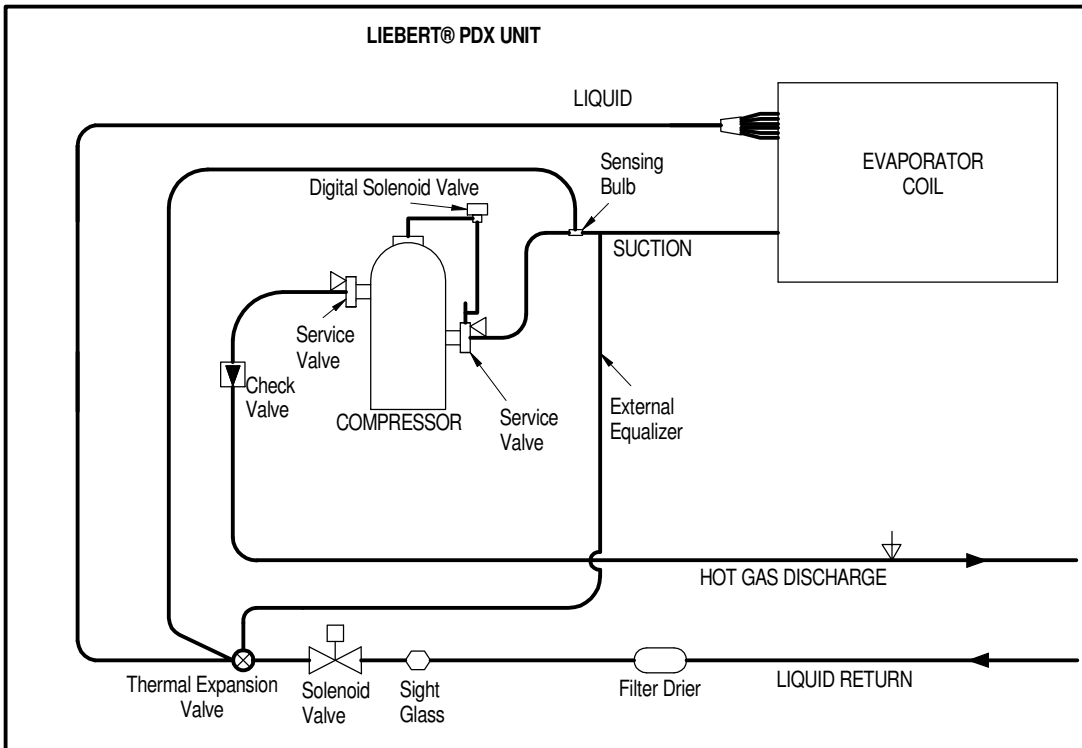
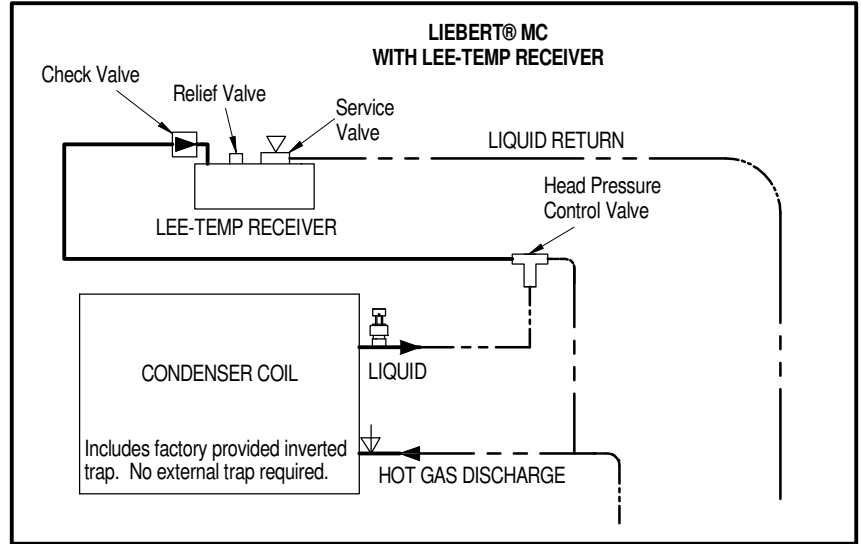
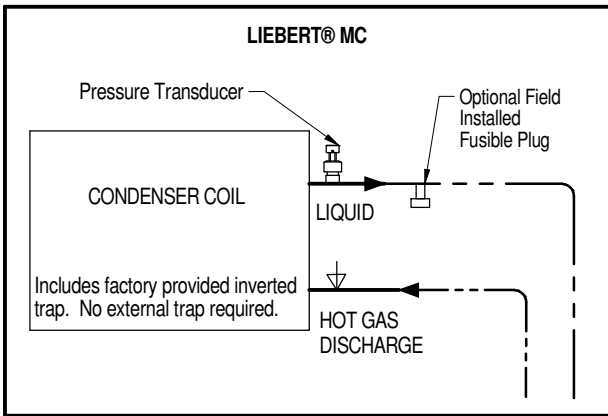

- FACTORY REFRIGERANT PIPING
- - - - - FIELD PIPING
- ▽ SERVICE / SCHRADER (ACCESS) CONNECTION NO VALVE CORE
- ▽ SERVICE / SCHRADER (ACCESS) CONNECTION WITH VALVE CORE

Notes:

1. Schematic representation shown. Do not use for specific connection locations.
2. Components are not supplied by Liebert® but are required for proper circuit operation and maintenance.
3. Traps must be installed and horizontal lines pitched to ensure proper oil return and to reduce liquid floodback to compressor. Pitch horizontal hot gas piping at a minimum of 1/2" per 10 feet (42mm per 10m) so that gravity will aid in moving oil in the direction of the refrigeration flow.
4. Do not isolate any refrigerant circuits from over pressurization protection.

PIPING SCHEMATIC AIR COOLED MODELS WITH EEV

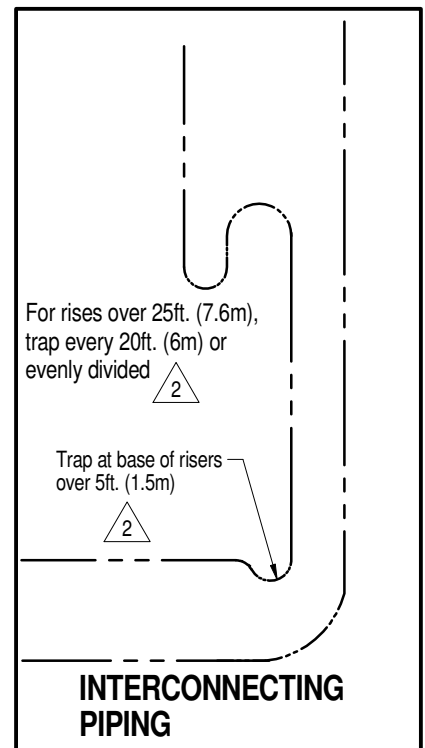
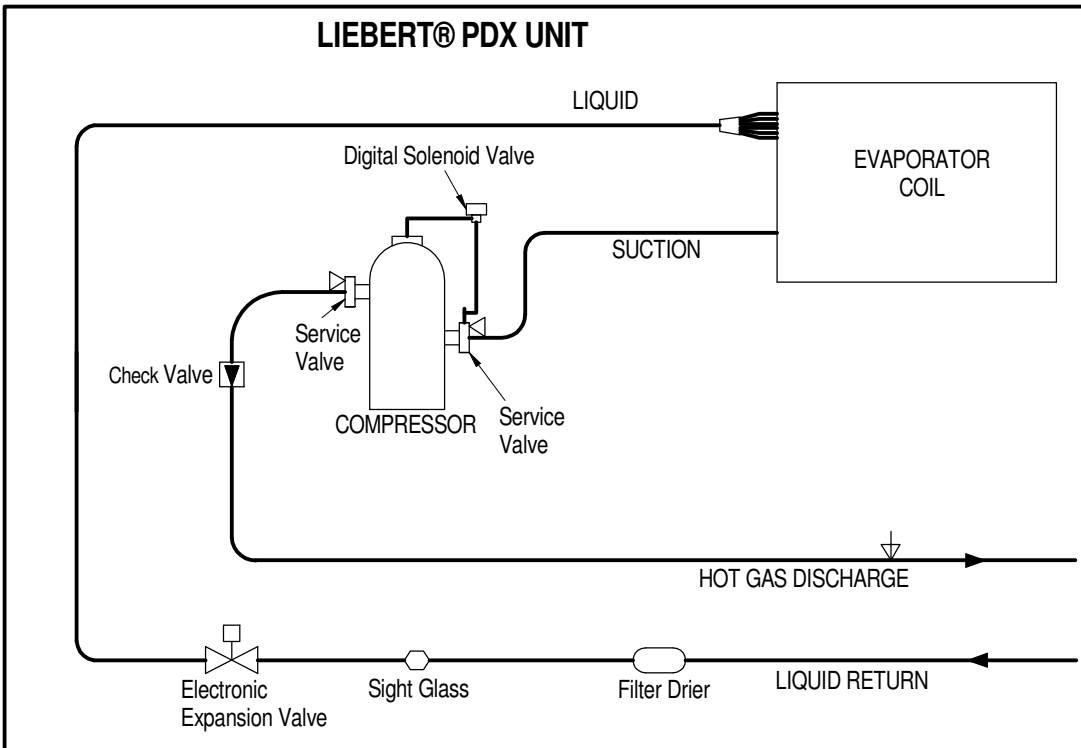
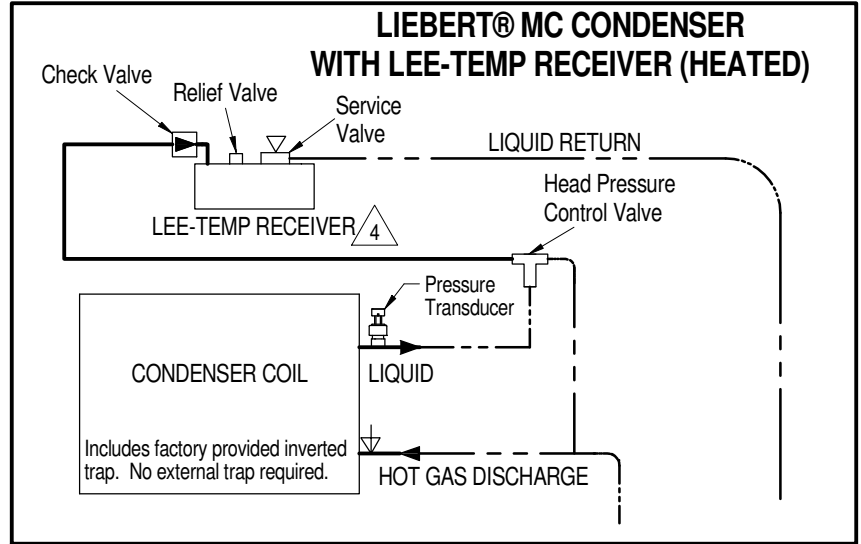
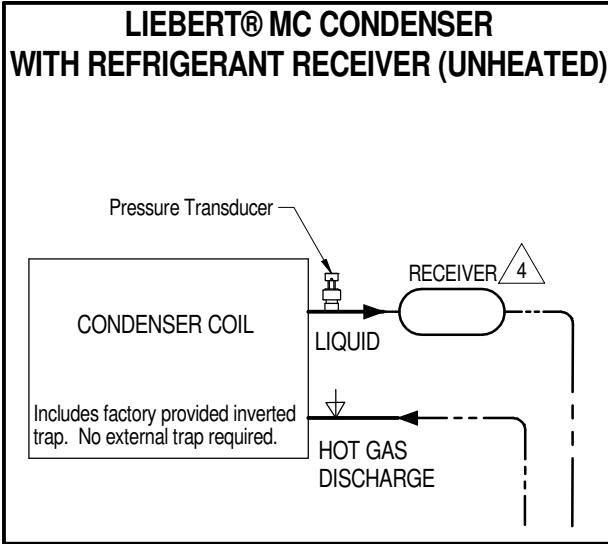

————— FACTORY REFRIGERANT PIPING
- - - - - FIELD PIPING

▽ SERVICE/SCHRADER (ACCESS) CONNECTION, NO VALVE CORE.
▽ SERVICE/SCHRADER (ACCESS) CONNECTION, WITH VALVE CORE.

Notes:

1. Schematic representation shown. Do not use for specific connection locations.

2. Components are not supplied by Liebert but are required for proper circuit operation and maintenance.

3. Traps must be installed and horizontal lines pitched to ensure proper oil return and to reduce liquid floodback to compressor. Pitch horizontal hot gas piping at a minimum of 1/2" per 10 feet (42mm per 10m) so that gravity will aid in moving oil in the direction of the refrigeration flow.

4. Refrigerant receiver or Lee-temp receiver required with Liebert® PDX unit with EEV option. The outlet of the receiver must be higher than the elevation of the EEV inside the indoor unit. This vertical height must not exceed 60ft. (18.3m).

5. Do not isolate any refrigerant circuits from over pressurization protection.

PIPING SCHEMATIC DA125, DA150 & DA165 W/ LIEBERT® MC WITHOUT RECEIVERS

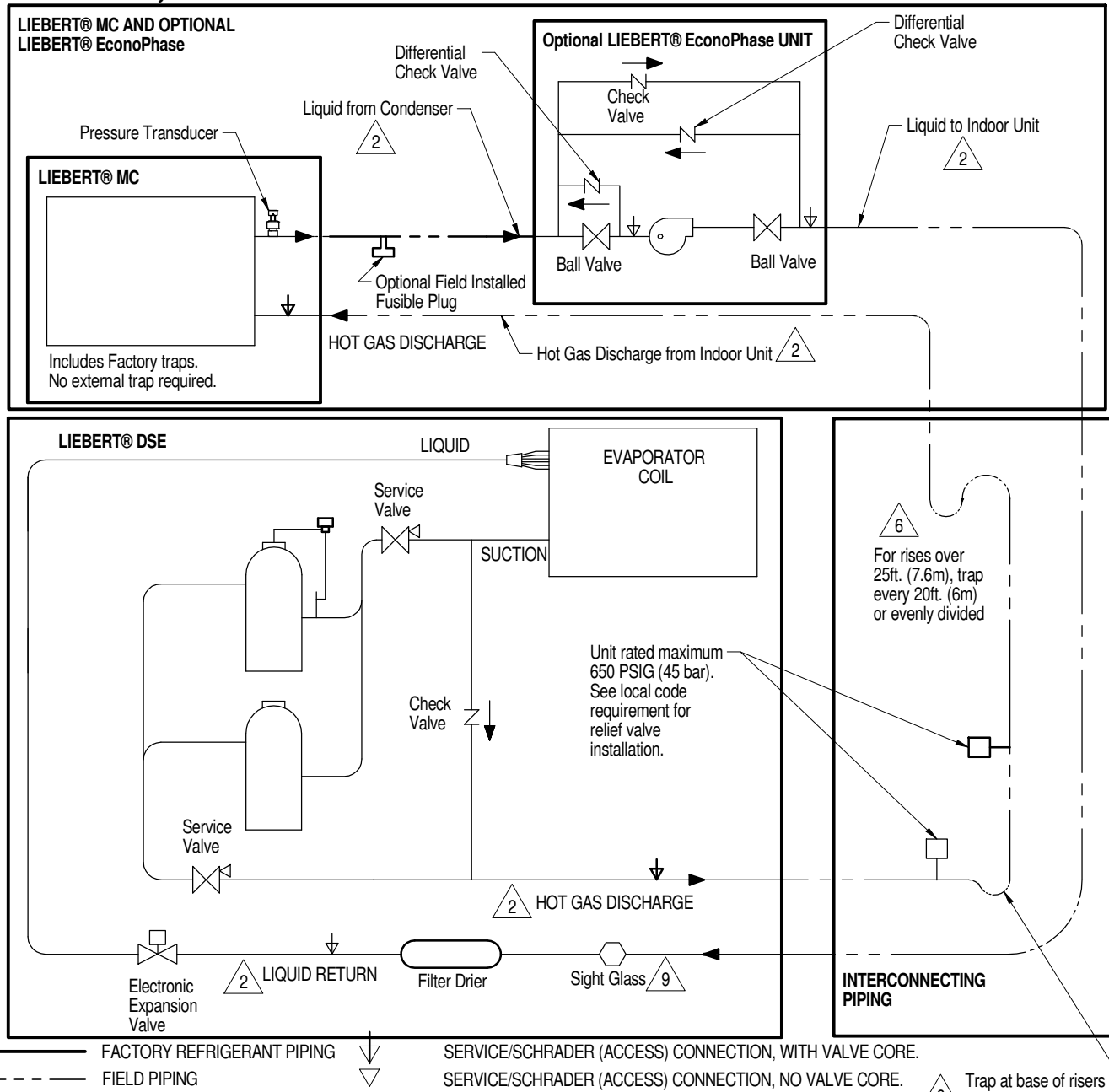

Notes:

1. Two refrigeration circuits provided. Single refrigeration circuit shown for clarity.
2. Circuit 1 must be maintained between indoor unit, condenser and Liebert® EconoPhase unit. Circuit 2 must be maintained between indoor unit, condenser and Liebert® EconoPhase unit.
3. Schematic representation shown. Do not use for specific connection locations.
4. The bottom of the condenser coil must be no greater than 60ft (18.3m) above and less than 15ft (4.6m) below the elevation of the EEV inside the indoor unit.
5. All indoor field refrigerant piping must be insulated, 1/2" minimum thickness. All outdoor field refrigeration piping does not need to be insulated. The installing contractor is responsible for the insulating, securing, protecting and the proper installation of all field refrigerant piping, observing the details outlined by the Engineer of Record.
6. Components are not supplied by Vertiv but are required for proper circuit operation and maintenance.
7. Traps must be installed and horizontal lines pitched to ensure proper oil return and to reduce liquid flood back to compressor. Pitch horizontal gas piping at a minimum of 1/2" per 10 feet (42mm per 10m) so that gravity will aid in moving oil in the direction of the refrigeration flow.
8. Do not isolate any refrigerant circuits from over pressurization protection.
9. Typical location for Sight Glass on DA150 and DA165. On DA125, Sight Glass is located between Filter Drier and Electronic Expansion Valve.

LIEBERT® ECONOPHASE

UNIT ARRANGEMENT DIAGRAM LIEBERT® MC WITHOUT RECEIVER AND SINGLE CIRCUIT LIEBERT® ECONOPHASE UNIT

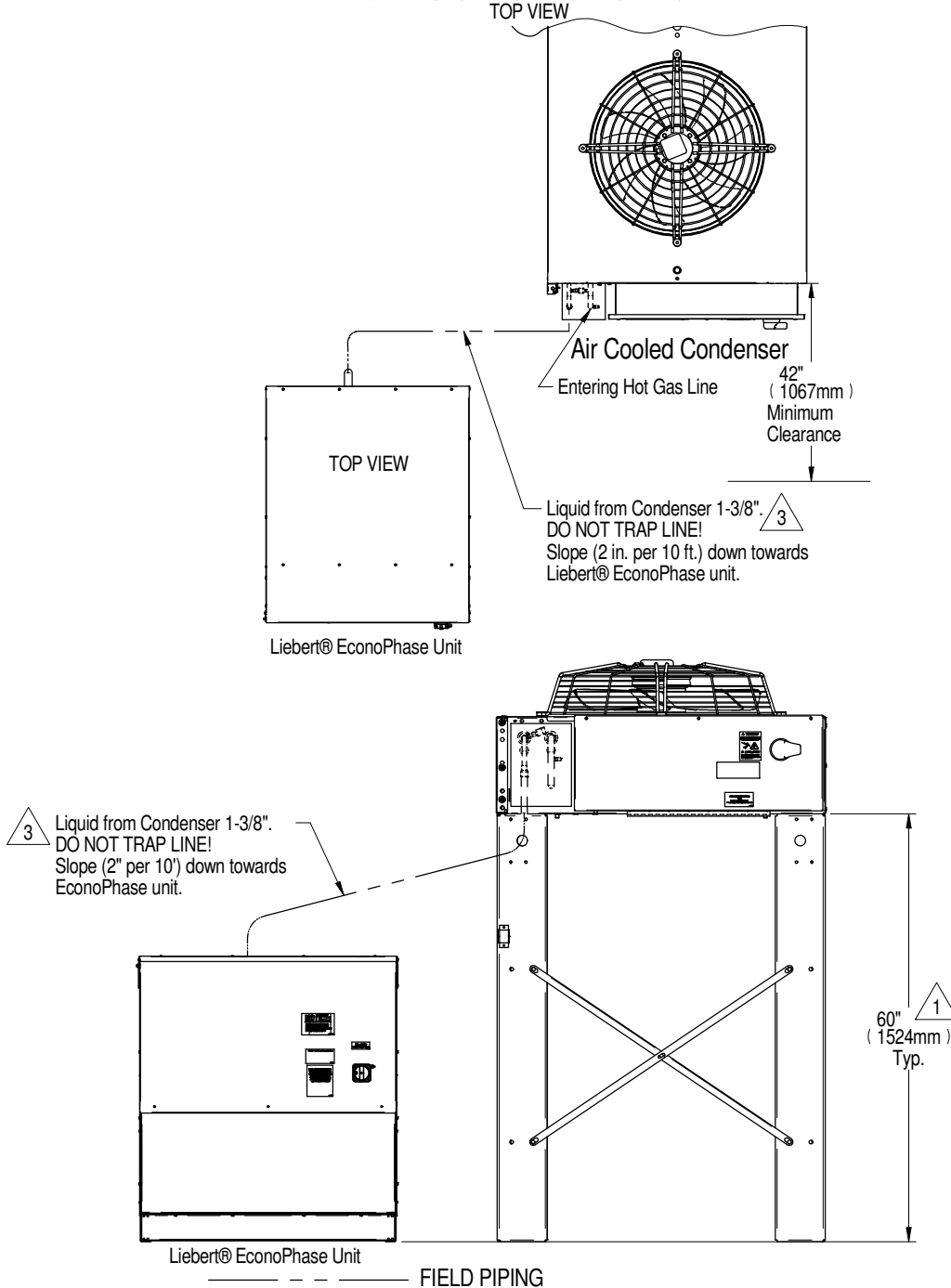

Notes:

1. For proper pump function, a minimum elevation difference of 60" (1524 mm) must be maintained between the bottom of condenser box to the bottom of Liebert® EconoPhase unit.
2. All indoor field refrigerant piping must be insulated, 1/2" minimum thickness. All outdoor field refrigeration piping does not need to be insulated. The installing contractor is responsible for the insulating, securing, protecting and the proper installation of all field refrigerant piping, observing the details outlined by the Engineer of Record.
3. Components are not supplied by Vertiv but are required for proper circuit operation and maintenance.
4. See DPN005215 for piping elevations.

PIPING SCHEMATIC

DA050, DA080 & DA085 W/ LIEBERT® MC WITHOUT RECEIVERS

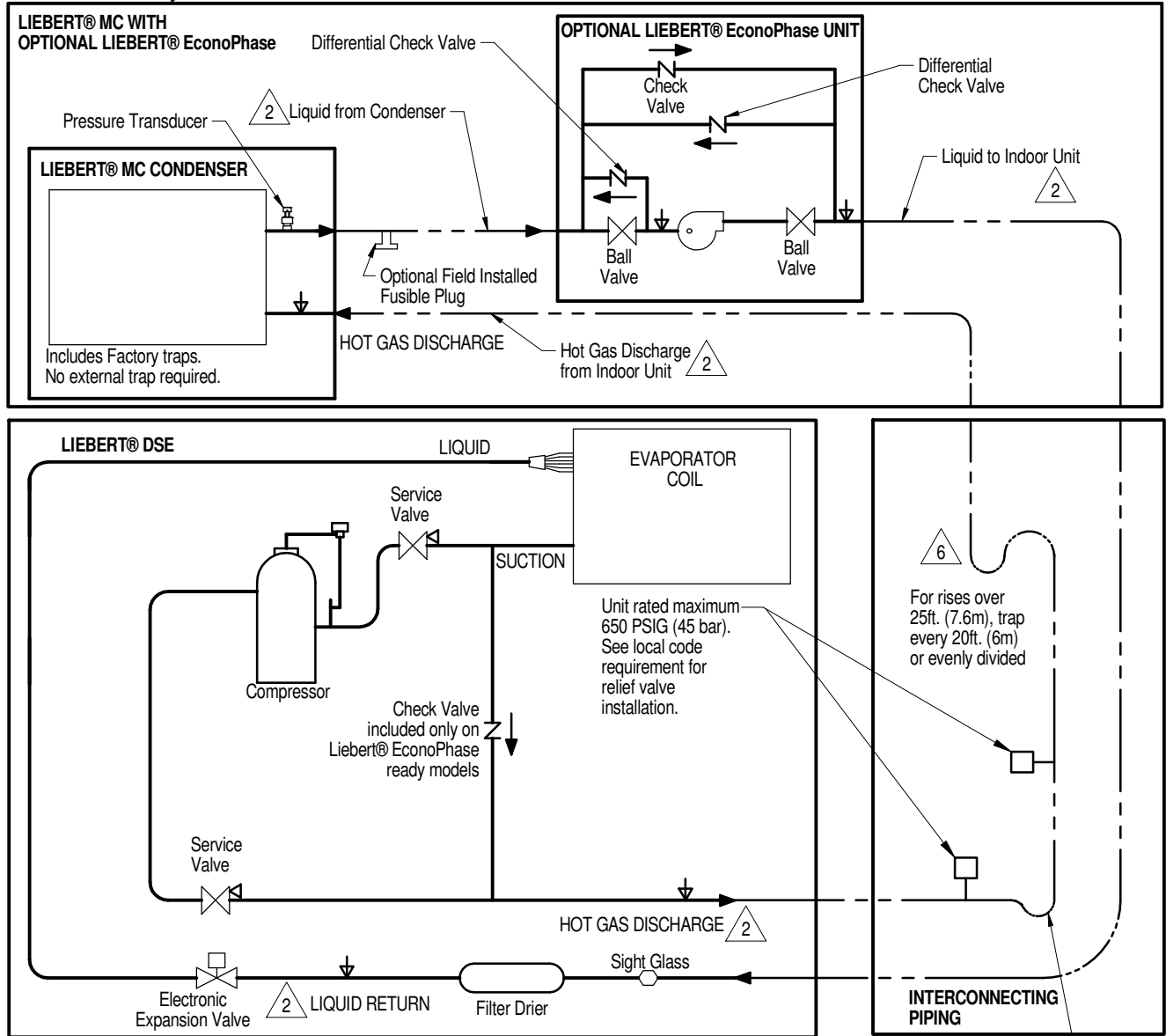

————— FACTORY REFRIGERANT PIPING
 - - - - - FIELD PIPING

▽ SERVICE/SCHRADER (ACCESS) CONNECTION, NO VALVE CORE.
 ▽ SERVICE/SCHRADER (ACCESS) CONNECTION, WITH VALVE CORE.

△ 6 Trap at base of risers over 5ft. (1.5m)

- Notes:
1. Single refrigeration circuit provided on DA050.
 2. Two refrigeration circuits provided on DA080 & DA085. Single refrigeration circuit shown for clarity.
 3. Circuit 1 must be maintained between indoor unit, condenser and Liebert® EconoPhase unit.
 4. Schematic representation shown. Do not use for specific connection locations.
 5. The bottom of the Condenser Coil must be no greater than 60ft. (18.3m) above, and less than 15ft. (4.6m) below the elevation of the EEV inside the indoor unit.
 6. All indoor field refrigerant piping must be insulated, 1/2" minimum thickness. All outdoor field refrigerant piping does not need to be insulated. The installing contractor is responsible for the insulating, securing, protecting and the proper installation of all field refrigerant piping, observing the details outlined by the Engineer of Record.
 7. Components are not supplied by Vertiv but are required for proper circuit operation and maintenance.
 8. Traps must be installed and horizontal lines pitched to ensure proper oil return and to reduce liquid flood back to compressor. Pitch horizontal hot gas piping at a minimum of 1/2" per 10 feet (42mm per 10m) so that gravity will aid in moving oil in the direction of refrigeration flow.
 9. Do not isolate any refrigeration circuits from over pressurization protection.

LIEBERT® ECONOPHASE

UNIT ARRANGEMENT DIAGRAM

LIEBERT® MC WITHOUT RECEIVER & DUAL CIRCUIT LIEBERT® ECONOPHASE UNIT

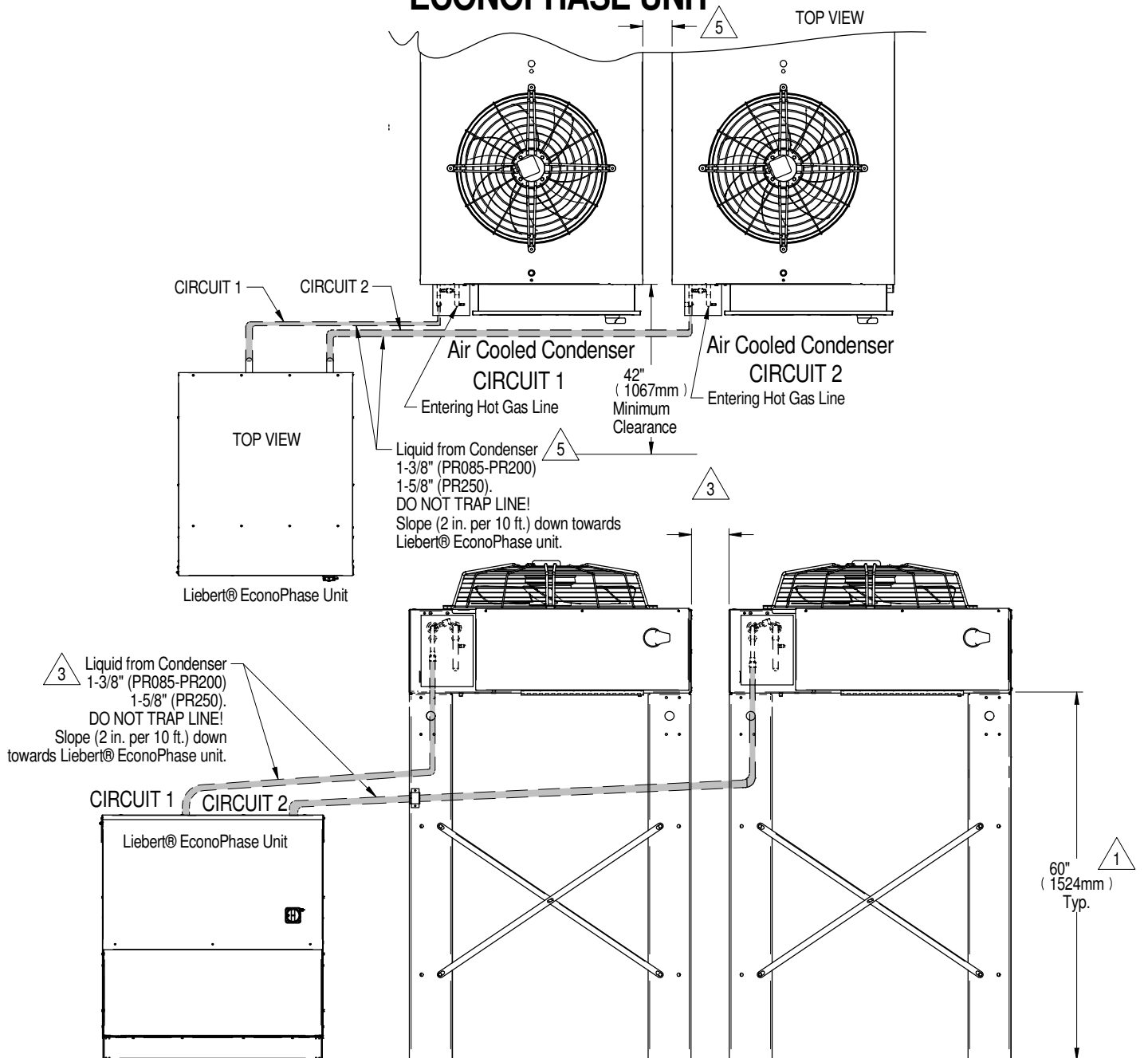

Notes:

FACTORY SUPPLIED, FIELD INSTALLED

FIELD PIPING

1. For proper pump function, a minimum elevation difference of 60" (1524 mm) must be maintained between the bottom of condenser box to the bottom of Liebert® EconoPhase unit.
2. All indoor field refrigerant piping must be insulated, 1/2" minimum thickness. All outdoor field refrigeration piping does not need to be insulated. The installing contractor is responsible for the insulating, securing, protecting and the proper installation of all field refrigerant piping, observing the details outlined by the Engineer of Record.
3. Components are not supplied by Vertiv but are required for proper circuit operation and maintenance.
4. For Piping Elevation refer to DPN005215.
5. Liebert® MC with legs taller than 18" (457mm) require a minimum spacing of 6" (152mm) for leg bracing.

LIEBERT® ECONOPHASE

UNIT ARRANGEMENT DIAGRAM LIEBERT® MC WITH RECEIVER & DUAL CIRCUIT LIEBERT® ECONOPHASE UNIT

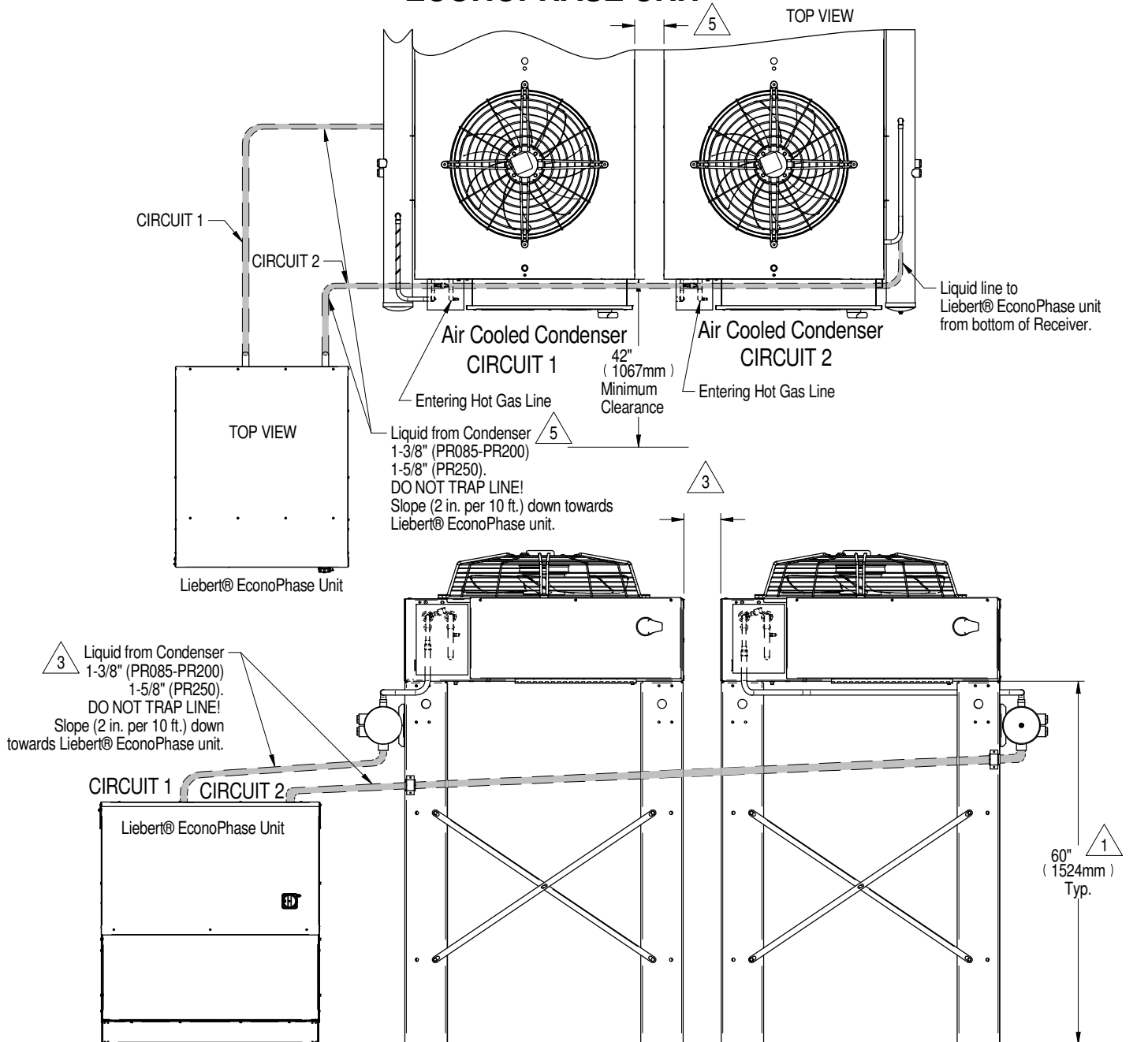

Notes:

FACTORY SUPPLIED, FIELD INSTALLED
FIELD PIPING

1. For proper pump function, a minimum elevation difference of 60" (1524 mm) must be maintained between the bottom of condenser box to the bottom of Liebert® EconoPhase unit.
2. All indoor field refrigerant piping must be insulated, 1/2" minimum thickness. All outdoor field refrigeration piping does not need to be insulated. The installing contractor is responsible for the insulating, securing, protecting and the proper installation of all field refrigerant piping, observing the details outlined by the Engineer of Record.
3. Components are not supplied by Vertiv but are required for proper circuit operation and maintenance.
4. For Piping Elevation refer to DPN005215.
5. Liebert® MC with legs taller than 18" (457mm) require a minimum spacing of 6" (152mm) for leg bracing.

PIPING DIMENSIONAL DATA SINGLE CIRCUIT 1 FAN, 2 FAN, 3 FAN & 4 FAN UNITS

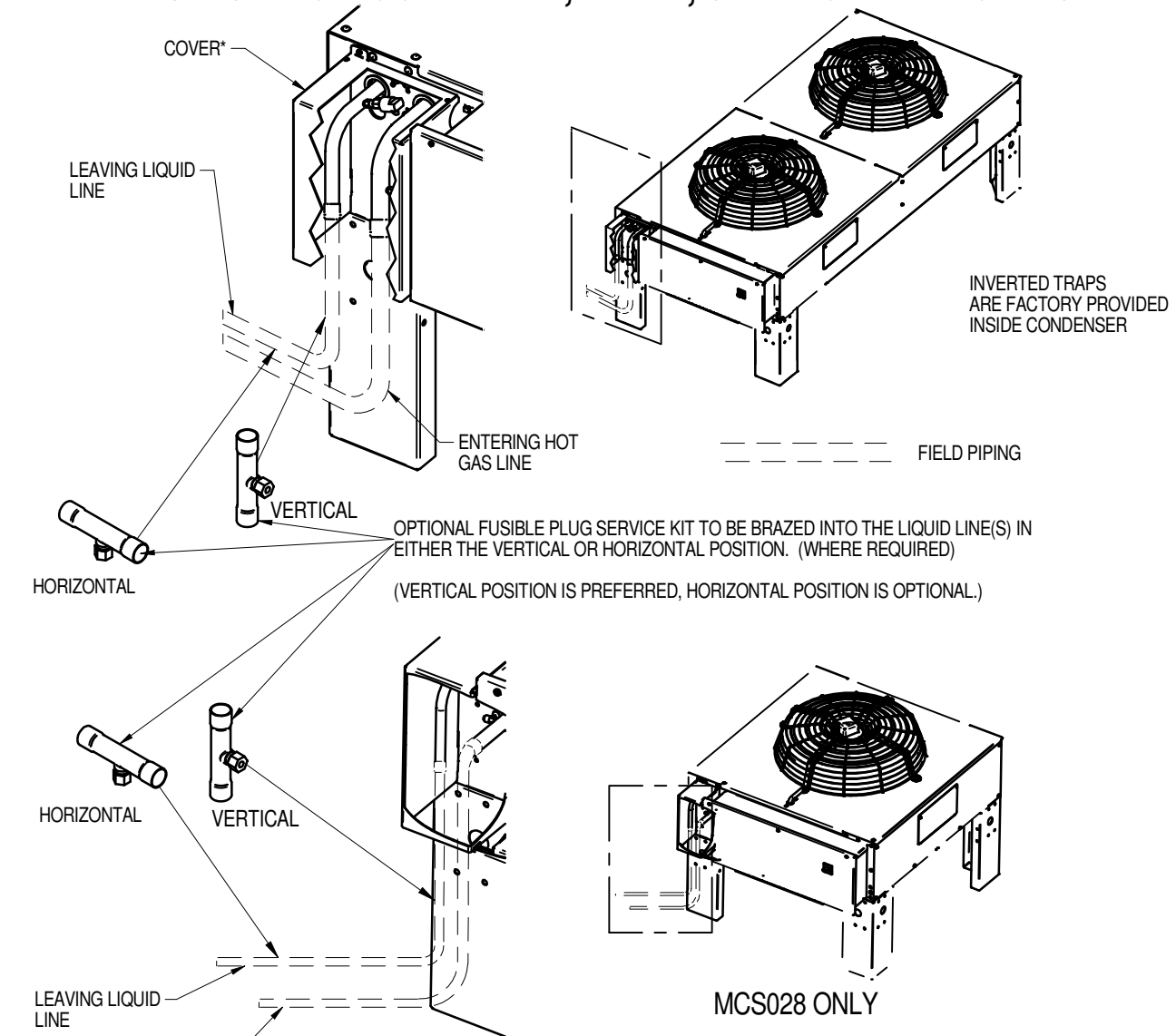

MODEL NO.	NUMBER OF FANS	CONDENSER CIRCUITS	CONNECTION SIZES, OD, IN	
			HOT GAS LINE	LIQUID LINE
MCS 028	1	1	7/8	5/8
MCM 040	1	1	7/8	5/8
MCM 080	2	1	1-1/8	7/8
MCL 055	1	1	1-1/8	7/8
MCL 110	2	1	1-3/8	1-1/8
MCL 165	3	1	1-3/8	1-1/8
MCL 220	4	1	1-5/8	1-3/8

* SHIPPING COVER IS NOT NECESSARY FOR PROPER CONDENSER OPERATION AND MAY BE RECYCLED IF FIELD PIPING INTERFERES WITH PROPER REATTACHMENT.

PIPING LOCATIONS SINGLE CIRCUIT WITH LIEBERT® LEE-TEMP

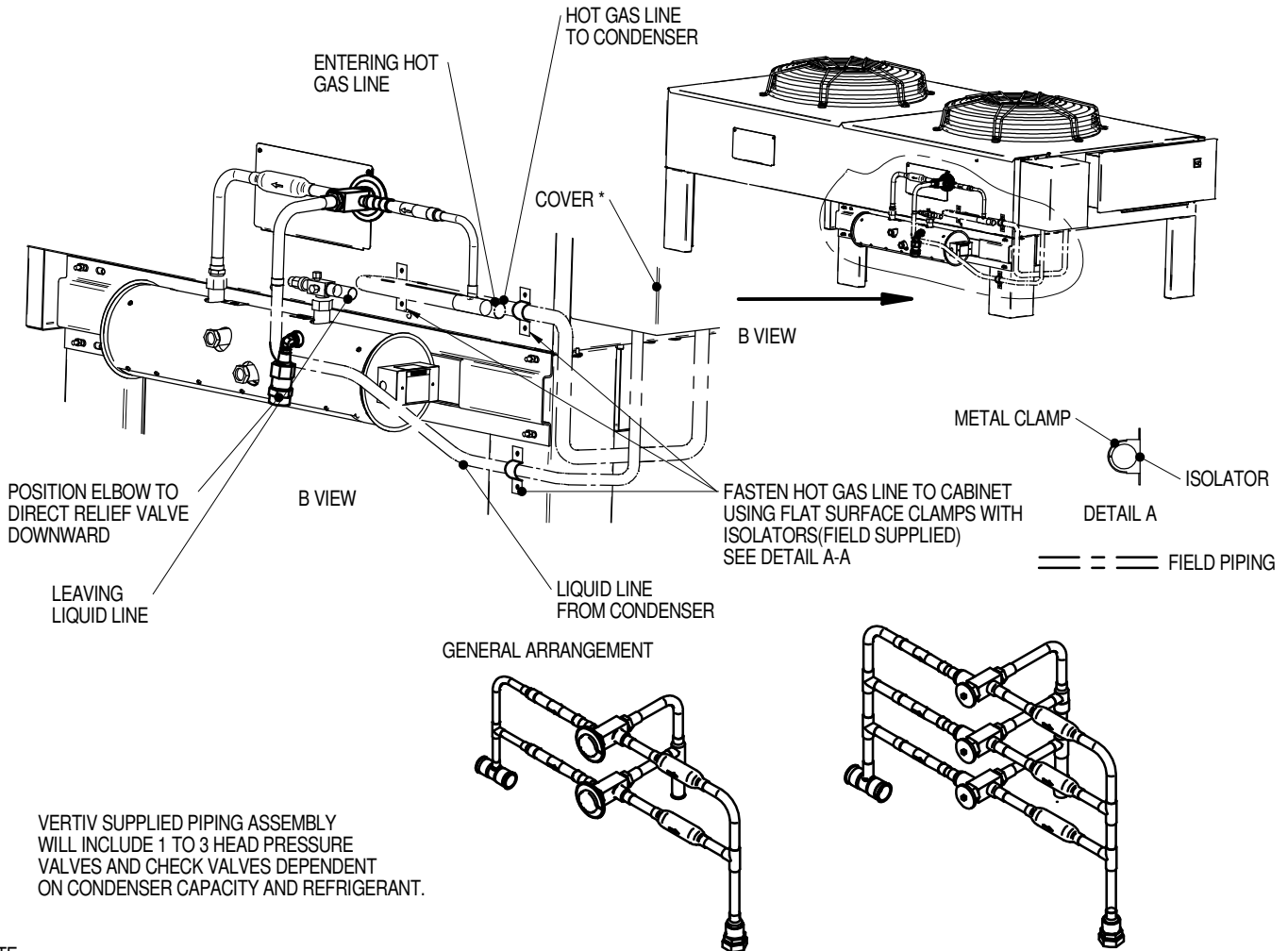

VERTIV SUPPLIED PIPING ASSEMBLY WILL INCLUDE 1 TO 3 HEAD PRESSURE VALVES AND CHECK VALVES DEPENDENT ON CONDENSER CAPACITY AND REFRIGERANT.

NOTE:

1. THE FOLLOWING MATERIALS ARE SUPPLIED BY VERTIV, SHIPPED LOOSE FOR EACH CIRCUIT AND FOR FIELD INSTALLATION: INSULATED LIEBERT® LEE-TEMP RECEIVER TANK WITH ELECTRIC HEATER PADS AND SIGHT GLASSES, PIPING ASSEMBLY WITH HEAD PRESSURE CONTROL VALVE AND CHECK VALVE, ROTO-LOCK VALVE AND PRESSURE RELIEF VALVE. ALL OTHER PIPING AND ELECTRICAL WIRING TO BE SUPPLIED AND INSTALLED BY OTHERS. ADDITIONAL CONDENSER LEG PER CIRCUIT WHEN REQUIRED, SHIPS WITH THE CONDENSER.

CONDENSER PIPING CONNECTION SIZES						
CONDENSER CONNECTIONS (ODS-INCHES)				LIEBERT® LEE-TEMP CONNECTIONS		
MODEL NO.	CONDENSER CIRCUITS	HOT GAS	LIQUID	HOT GAS TEE (IDS-INCHES)	LIQ TO L-T VALVE (ODS-INCHES)	RECEIVER OUT ROTO LOCK (IDS-INCHES)
MCS028	1	7/8	5/8	7/8	5/8	5/8
MCM040						
MCM080		1-1/8	7/8	1-1/8	7/8	1-1/8
MCL055						7/8
MCL110		1-3/8	1-1/8	1-3/8	1-1/8	1-1/8
MCL165						
MCL220		1-5/8	1-3/8	1-5/8	1-3/8	1-3/8

* SHIPPING COVER IS NOT NECESSARY FOR PROPER CONDENSER OPERATION AND MAY BE RECYCLED IF FIELD PIPING INTERFERES WITH PROPER REATTACHMENT.

PIPING DIMENSIONAL DATA DUAL CIRCUIT 2 FAN & 4 FAN UNITS

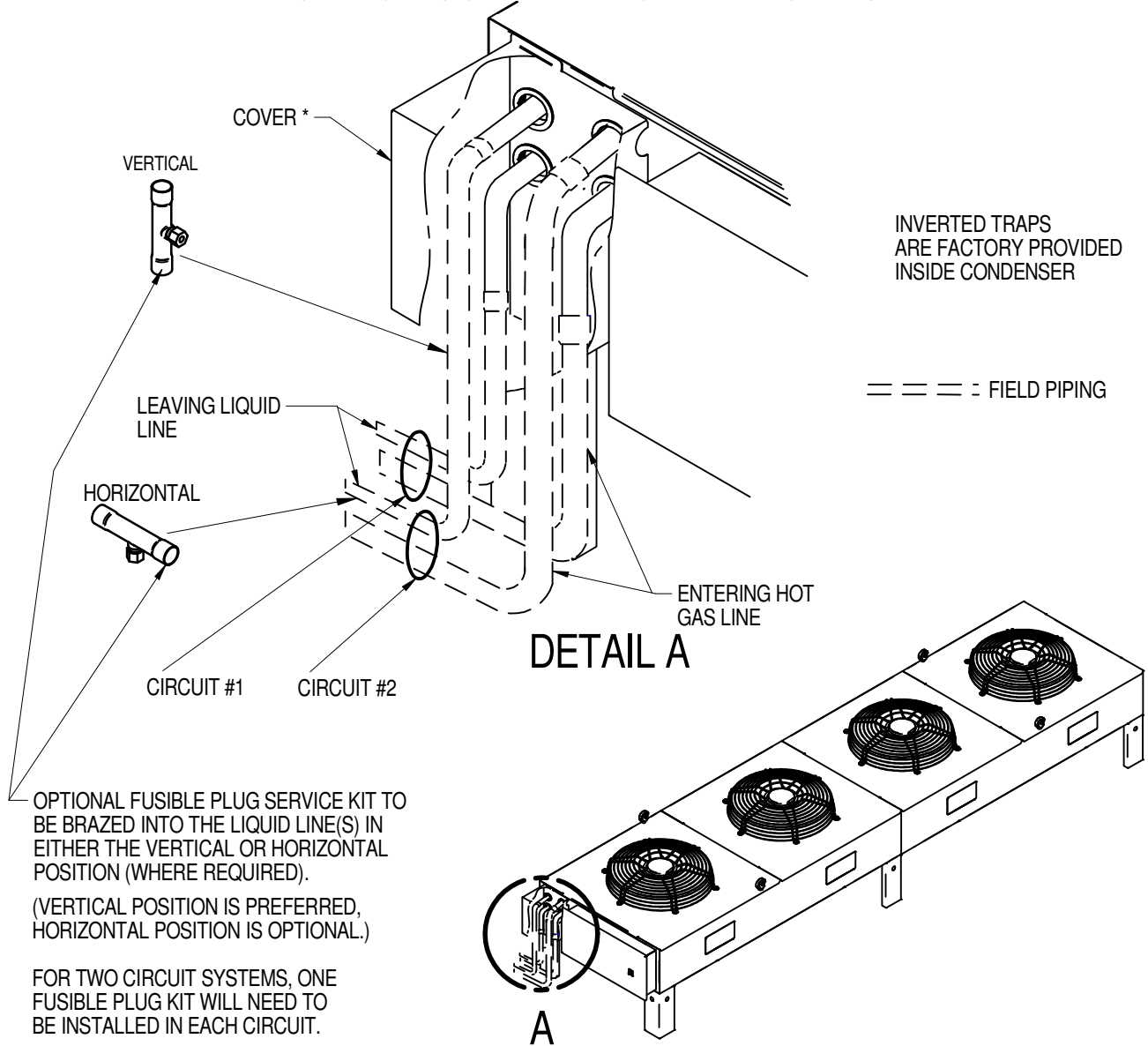

MODEL NO.	NUMBER OF FANS	CONDENSER CIRCUITS	CONNECTION SIZES ,OD,IN	
			HOT GAS LINE	LIQUID LINE
MCS 056	2	2	7/8	5/8
MCM 080	2	2	7/8	5/8
MCL 110	2	2	1-1/8	7/8
MCM 160	4	2	1-1/8	7/8
MCL 220	4	2	1-3/8	1-1/8

* SHIPPING COVER IS NOT NECESSARY FOR PROPER CONDENSER OPERATION AND MAY BE RECYCLED IF FIELD PIPING INTERFERES WITH PROPER REATTACHMENT.

PIPING: DIMENSIONAL DATA WITH LIEBERT® LEE-TEMP DUAL CIRCUIT CONDENSERS

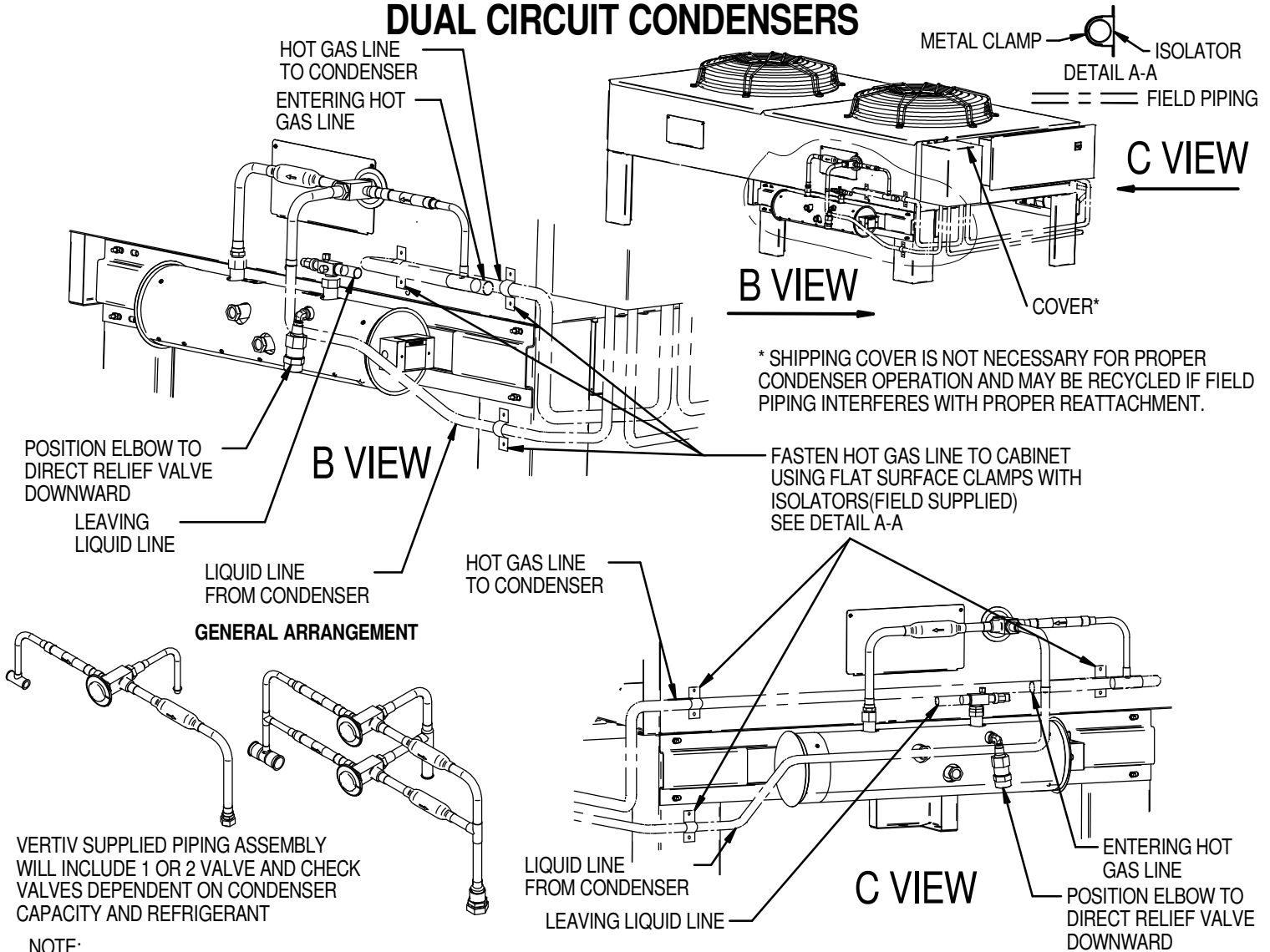

VERTIV SUPPLIED PIPING ASSEMBLY WILL INCLUDE 1 OR 2 VALVE AND CHECK VALVES DEPENDENT ON CONDENSER CAPACITY AND REFRIGERANT

NOTE:

- THE FOLLOWING MATERIALS ARE SUPPLIED BY VERTIV, SHIPPED LOOSE FOR EACH CIRCUIT, AND FOR FIELD INSTALLATION: INSULATED LIEBERT® LEE-TEMP RECEIVER TANK WITH ELECTRIC HEATER PADS AND SIGHT GLASSES, PIPING ASSEMBLY WITH HEAD PRESSURE CONTROL VALVE AND CHECK VALVE, ROTO-LOCK VALVE AND PRESSURE RELIEF VALVE. ALL OTHER PIPING AND ELECTRICAL WIRING TO BE SUPPLIED AND INSTALLED BY OTHERS. AN ADDITIONAL CONDENSER LEG PER CIRCUIT TO BE SHIPPED WITH THE CONDENSER.
- FOR RUNS LONGER THAN 150FT. (45.7M) EQUIV. LENGTH, CONSULT FACTORY FOR PROPER LINE SIZING.

CONDENSER PIPING CONNECTION SIZES						
CONDENSER CONNECTIONS(ODS-INCHES)				LIEBERT® LEE-TEMP CONNECTIONS		
MODEL NO.	CIRCUIT NO.	HOT GAS	LIQUID	HOT GAS TEE (IDS-INCHES)	LIQ TO L-T VALVE (ODS-INCHES)	RECEIVER OUT ROTO-LOCK (IDS-INCHES)
MCS056	2	7/8	5/8	7/8	5/8	5/8
MCM080	2	7/8	5/8	7/8	5/8	5/8
MCL110	2	1-1/8	7/8	1-1/8	7/8	7/8
MCM160	2	1-1/8	7/8	1-1/8	7/8	1-1/8
MCL220	2	1-3/8	1-1/8	1-3/8	1-1/8	1-1/8

**ELECTRICAL FIELD CONNECTIONS
PREMIUM EFFICIENCY CONTROL**

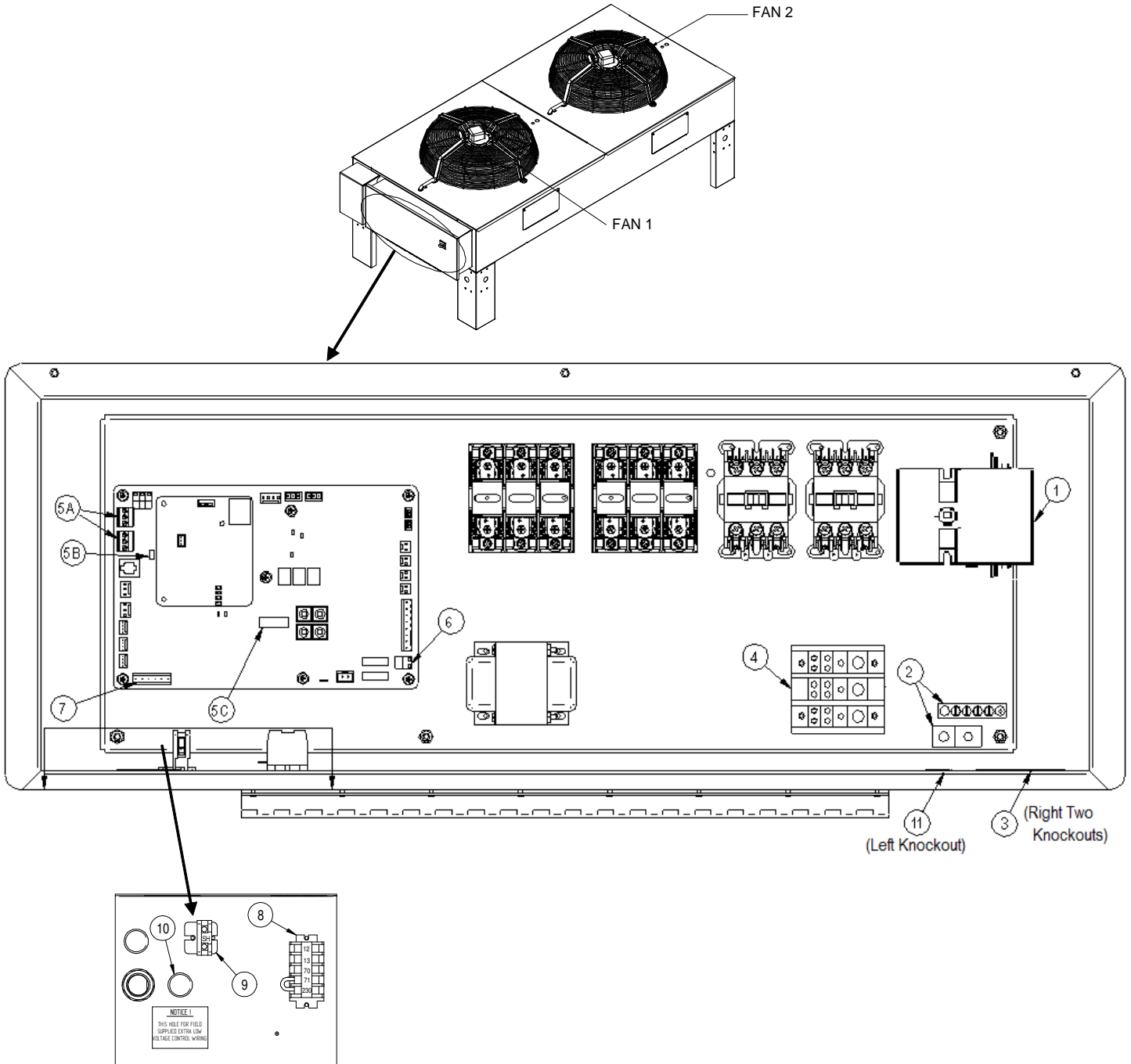

KEY ELECTRICAL DETAILS:

- 1) **Three phase electrical service** – Terminals are on top of disconnect switch for one and two fan units. Terminals are on bottom of disconnect switch for three and four fan units. Three phase service not by Vertiv. See note 5.
- 2) **Earth ground** – Field lug terminal for earth ground connection. Ground terminal strip for fan motor ground connection.
- 3) **Primary high voltage entrance** – Two 7/8" (22.2mm) diameter knockouts located at the bottom of the enclosure.
- 4) **SPD field connection terminals** – High voltage surge protective device (SPD) terminals. SPD is an optional device.



ELECTRICAL FIELD CONNECTIONS PREMIUM EFFICIENCY CONTROL

- 5) **CANbus terminal connections** – Field terminals for CANbus cable connection.
- 5A is the CANbus connectors.
 - TB49-1 is the input terminal for CANbus high.
 - TB49-3 is the input terminal for CANbus low.
 - TB50-1 is output terminal for CANbus high.
 - TB50-3 is the output terminal for CANbus low.
 - Each CANbus cable shield is connected to terminal “SH”, item 9.
 - 5B is the “END OF LINE” jumper.
 - 5C is the CANbus “DEVICE ADDRESS DIP SWITCH”. CANbus cable not by Vertiv. See Note 2. (below)
- 6) **Remote unit shutdown** – Replace existing jumper between terminals TB38-1 and TB38-2 with field supplied normally closed switch having a minimum 75VA 24VAC rating. Use field supplied Class 1 wiring. (This is an optional feature that may be owner specified.)
- 7) **Alarm terminal connections** –
- a. Common Alarm Relay indicates when any type of alarm occurs. TB74-1 is common, TB74-2 is normally open, and TB74-3 is normally closed. 1 Amp 24VAC is the maximum load. Use Class 1 field supplied wiring.
 - b. Shutdown Alarm Relay indicates when condenser loses power, or when a critical alarm has occurred that shuts down the condenser unit. TB74-4 is common, TB74-5 is normally open, and TB74-6 is normally closed. 1 Amp 24VAC is the maximum load. Use Class 1 field supplied wiring.
- 8) **Indoor unit interlock and SPD alarm terminals** –
- a. On any call for compressor operation, normally open contact is closed across terminals 70 and 71 for Circuit 1, and normally open contact is closed across terminals 70 and 230 for Circuit 2 from indoor room unit.
 - b. During SPD alarm, normally open contact is closed across terminals 12 & 13. SPD is an optional device.
- 9) **CANbus shield terminal** – Terminal for field shield connection of the CANbus field supplied cables. The shield of CANbus field supplied cables must not be connected to ground at the condenser.
- 10) **Primary low voltage entrance** – One 7/8” (22.2mm) diameter knockout that is free for customer low voltage wiring.
- 11) **SPD entrance** – One 7/8” (22.2mm) diameter knockout hole located at the bottom of the enclosure. High voltage surge protective device (SPD) is optional.

NOTES:

1. Refer to specification sheet for unit voltage rating, full load amp, and wire size amp ratings.
2. The CANbus wiring is field supplied and must be:
 - Braided shield or foil shield with drain wire
 - Shield must be wired to ground at indoor unit
 - 22-18AWG stranded tinned copper
 - Twisted pair (minimum 4 twists per foot)
 - Low Capacitance (15pF/FT or less)
 - Must be rated to meet local codes and conditions
 - EXAMPLES BELDEN 89207 (PLENUM RATED), OR ALPHA WIRE 6454 CATEGORY 5, 5E, OR HIGHER
3. Do not run in same conduit, raceway, or chase as high voltage wiring.
4. For CANbus network lengths greater than 450FT (137M) call Factory.



LIEBERT® MC

ELECTRICAL FIELD CONNECTIONS PREMIUM EFFICIENCY CONTROL

5. All wiring must be sized and selected for insulation case per NEC and other local codes.
6. Do not bend cables to less than four times the diameter of the cable.
7. Do not deform cables when securing in bundles or when hanging them.
8. Avoid running the cables by devices that may introduce noise, such as machines, fluorescent lights, and electronics.
9. Avoid stretching cables.
10. The electrically commutated (EC) motors included in the Liebert® MC are suitable for connection to power supplies with a solidly grounded neutral or high resistance to ground or corner ground.
 - a. Acceptable power supplies for 208 to 575V nominal units:
 - 208V wye with solidly grounded neutral and 120V line to ground;
 - 380V wye with solidly grounded neutral and 220V line to ground;
 - 480V wye with solidly grounded neutral and 277V line to ground;
 - 575V wye with solidly grounded neutral and 332V line to ground (uses step-down transformer);
 - Wye with high resistance (or impedance) ground;
 - Delta with corner ground
 - b. Unacceptable power supplies for 208V to 575V nominal units:
 - Delta without ground or with floating ground;
 - Delta with grounded center tap.

ELECTRICAL FIELD CONNECTIONS PREMIUM EFFICIENCY CONTROL WITH LIEBERT® LEE-TEMP

Electrical Connections for Liebert® Lee-Temp Receiver

Liebert® Lee-Temp receiver tank (1 per circuit).

NOTE: Heater pad voltage available for
120V/1 phase/60 Hz or 230V/1 phase/60Hz
150 or 300 Watt, varies by condenser.

Electrical connection box with cover.
(Cover removed for clarity.)

Electrical service connection. Pigtails in electric handy box
are factory wired to Liebert® Lee-Temp heater pads for field
connection of separate continuous electric source, wire not by Vertiv.

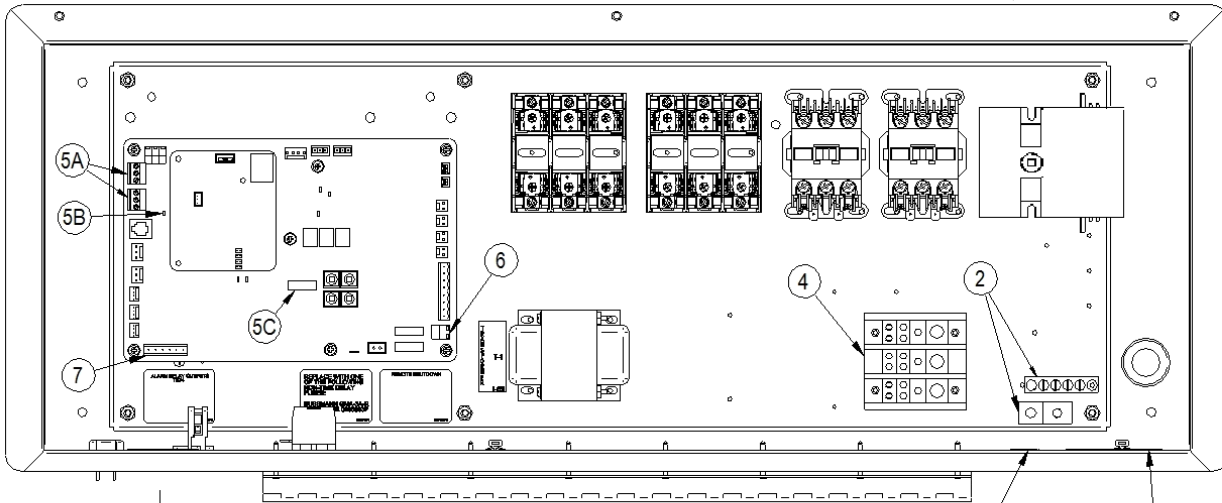
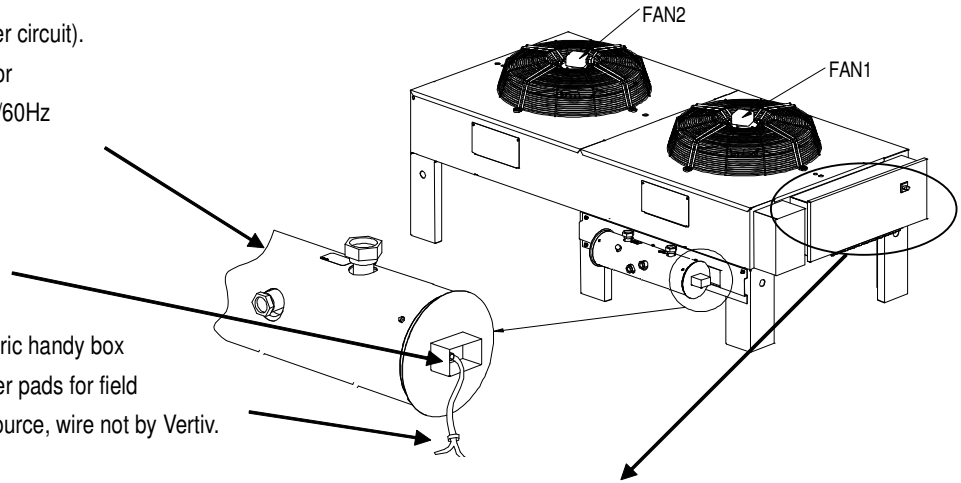

(LEFT KNOCKOUT) (RIGHT TWO KNOCKOUTS)

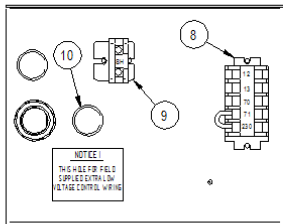

KEY ELECTRICAL DETAILS:

- 1) **Three phase electrical service** – Terminals are on top of disconnect switch for one and two fan units. Terminals are on bottom of disconnect switch for three and four fan units. Three phase service not by Vertiv. See Note 5 (below).
- 2) **Earth ground** – Field lug terminal for earth ground connection. Ground terminal strip for fan motor ground connection.
- 3) **Primary high voltage entrance** – Two 7/8" (22.2mm) diameter knockouts located at the bottom of the enclosure.
- 4) **SPD field connection terminals** – High voltage surge protective device (SPD) terminals. SPD is an optional device.

ELECTRICAL FIELD CONNECTIONS

PREMIUM EFFICIENCY CONTROL WITH LIEBERT® LEE-TEMP

- 5) **CANbus terminal connections** – Field terminals for CANbus cable connection.
- 5A is the CANbus connectors.
 - TB49-1 is the input terminal for CANbus high.
 - TB49-3 is the input terminal for CANbus low.
 - TB50-1 is output terminal for CANbus high.
 - TB50-3 is the output terminal for CANbus low.
 - Each CANbus cable shield is connected to terminal “SH”, item 9.
 - 5B is the “END OF LINE” jumper.
 - 5C is the CANbus “DEVICE ADDRESS DIP SWITCH”. CANbus cable not by Vertiv. See Note 2 (below).
- 6) **Remote unit shutdown** – Replace exiting jumper between terminals TB38-1 and TB38-2 with field supplied normally closed switch having a minimum 75VA 24VAC rating. Use field supplied Class 1 wiring. (This is an optional feature that may be owner specified.)
- 7) **Alarm terminal connections** –
- a. Common Alarm Relay indicates when any type of alarm occurs. TB74-1 is common, TB74-2 is normally open, and TB74-3 is normally closed. 1 Amp 24VAC is the maximum load. Use Class 1 field supplied wiring.
 - b. Shutdown Alarm Relay indicates when condenser loses power, or when a critical alarm has occurred that shuts down the condenser unit. TB74-4 is common, TB74-5 is normally open, and TB74-6 is normally closed. 1 Amp 24VAC is the maximum load. Use Class 1 field supplied wiring.
- 8) **Indoor unit interlock and SPD alarm terminals** –
- a. On any call for compressor operation, normally open contact is closed across terminals 70 & 71 for Circuit 1, and normally open contact is closed across terminals 70 & 230 for Circuit 2 from indoor room unit.
 - b. During SPD alarm, normally open contact is closed across terminals 12 & 13. SPD is an optional device.
- 9) **CANbus shield terminal** – Terminal for field connection of the CANbus field supplied cables. Shield of CANbus field supplied cables must not be connected to ground.
- 10) **Primary low voltage entrance** – One 7/8” (22.2mm) diameter knockout that is free for customer low voltage wiring.
- 11) **SPD entrance** – One 7/8” (22.2mm) diameter knockout hole located at the bottom of the enclosure. High voltage surge protective device (SPD) is optional.

NOTES:

1. Refer to specification sheet for unit voltage rating, full load amp, and wire size amp ratings.
2. The CANbus wiring is field supplied and must be:
 - Braided shield or foil shield with drain wire
 - Shield must be wired to ground at indoor unit
 - 22-18AWG stranded tinned copper
 - Twisted pair (minimum 4 twists per foot)
 - Low Capacitance (15pF/FT or less)
 - Must be rated to meet local codes and conditions
 - EXAMPLES BELDEN 89207 (PLENUM RATED), OR ALPHA WIRE 6454 CATEGORY 5, 5E, OR HIGHER
3. Do not run in same conduit, raceway, or chase as high voltage wiring.
4. For CANbus network lengths greater than 450FT (137M) call Factory.



LIEBERT® MC

ELECTRICAL FIELD CONNECTIONS

PREMIUM EFFICIENCY CONTROL WITH LIEBERT® LEE-TEMP

5. All wiring must be sized and selected for insulation case per NEC and other local codes.
6. Do not bend cables to less than four times the diameter of the cable.
7. Do not deform cables when securing in bundles or when hanging them.
8. Avoid running the cables by devices that may introduce noise, such as machines, fluorescent lights, and electronics.
9. Avoid stretching cables.
10. The electrically commutated (EC) motors included in the Liebert® MC are suitable for connection to power supplies with a solidly grounded neutral or high resistance to ground or corner ground.
 - A. Acceptable power supplies for 208 to 575V nominal units:
 - 208V wye with solidly grounded neutral and 120V line to ground;
 - 380V wye with solidly grounded neutral and 220V line to ground;
 - 480V wye with solidly grounded neutral and 277V line to ground;
 - 575V wye with solidly grounded neutral and 332V line to ground (uses step-down transformer);
 - Wye with high resistance (or impedance) ground;
 - Delta with corner ground
 - B. Unacceptable power supplies for 208V to 575V nominal units:
 - Delta without ground or with floating ground;
 - Delta with grounded center tap.

CANbus & INTERLOCK COMMUNICATIONS USING 1 LIEBERT® MC & OPTIONAL LIEBERT® ECONOPHASE UNIT

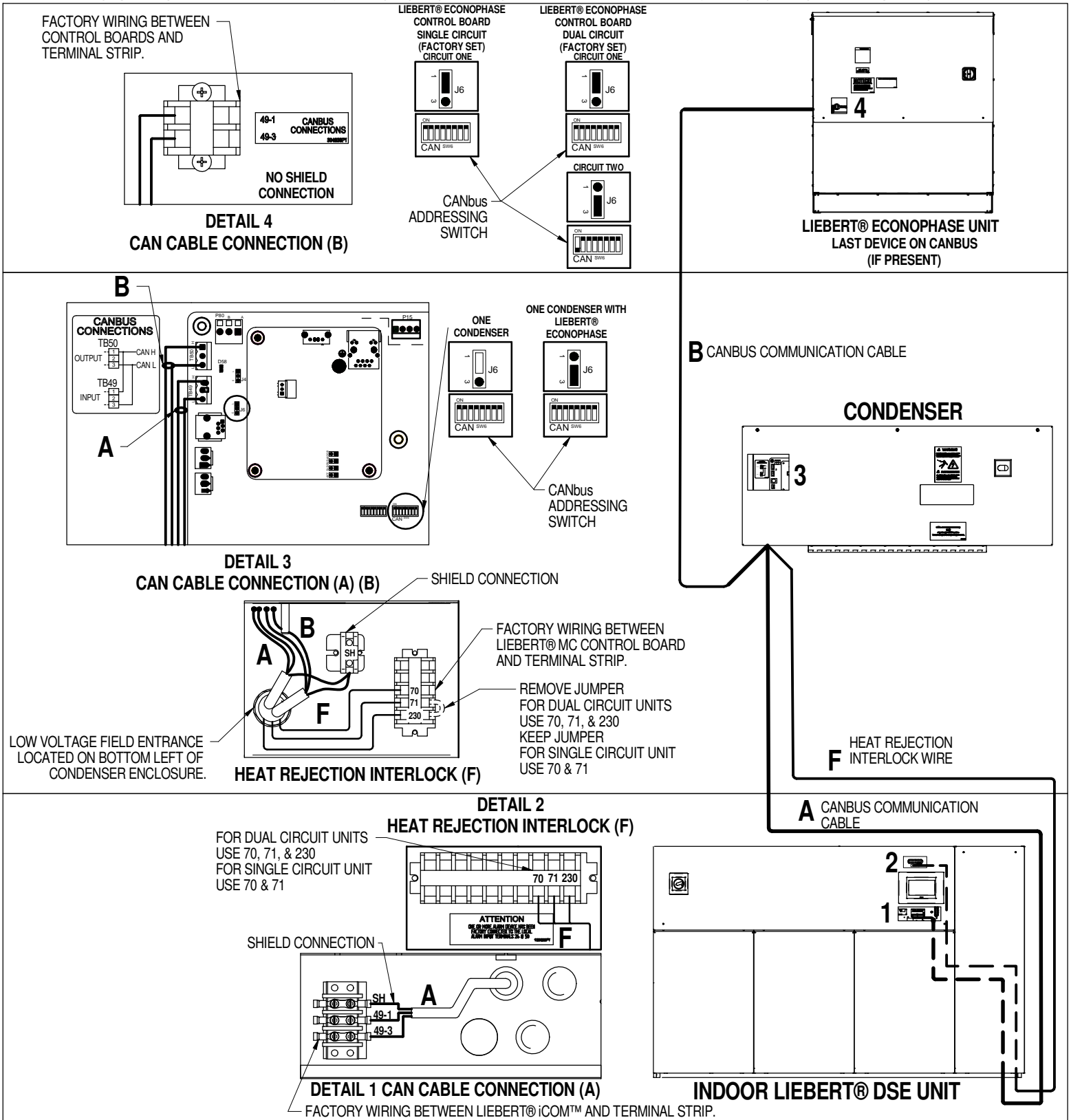



LIEBERT® DSE

CANbus & INTERLOCK COMMUNICATIONS USING 1 LIEBERT® MC & OPTIONAL LIEBERT® ECONOPHASE UNIT

COMPONENT NOTES:

1. COMPONENT APPEARANCE, ORIENTATION , AND POSITION MAY VARY BETWEEN PRODUCT LINES. TERMINAL NAMES AND CALLOUTS REMAIN CONSTANT.
2. ALL CIRCUITS TO THESE CONNECTION POINTS ARE CLASS 2.

CAN & CABLE NOTES (A, B):

1. CABLE MUSTHAVE THE FOLLOWING SPECIFICATIONS:
 - BRAIDED SHIELD OR FOIL SHIELD WITH DRAIN WIRE
 - SHIELD MUST BE WIRED TO GROUND AT INDOOR UNIT
 - 22-18AWG STRANDED TINNED COPPER
 - TWISTED PAIR (MINIMUM 4 TWISTS PER FOOT)
 - LOW CAPACITANCE (15pF/FT OR LESS)
 - MUST BE RATED TO MEET LOCAL CODES AND CONDITIONS.
 - EXAMPLES BELDEN 89207 (PLENUM RATED), OR ALPHA WIRE 6454 CATEGORY 5, 5E, OR HIGHER.
2. DO NOT RUN IN SAME CONDUIT, RACEWAY, OR CHASE AS HIGH VOLTAGE WIRING.
3. FOR CANBUS NETWORK LENGTHS GREATER THAN 450FT(137M), CONTACT VERTIV FACTORY.

INTERLOCK WIRE NOTES (F):

1. FIELD SUPPLIED WIRE
 - 2 CONDUCTOR 18AWG OR GREATER FOR SINGLE REFRIGERANT CIRCUIT DSE UNITS.
 - 3 CONDUCTOR 18AWG OR GREATER FOR DUAL REFRIGERANT CIRCUIT DSE UNITS.
 - RATED 600V
2. RUN FIELD SUPPLIED WIRES BETWEEN THE INDOOR UNIT AND THE CONDENSER.

CANbus & INTERLOCK CONNECTIONS

USING 2 LIEBERT® MC UNITS W/ OPTIONAL LIEBERT® ECONOPHASE UNIT

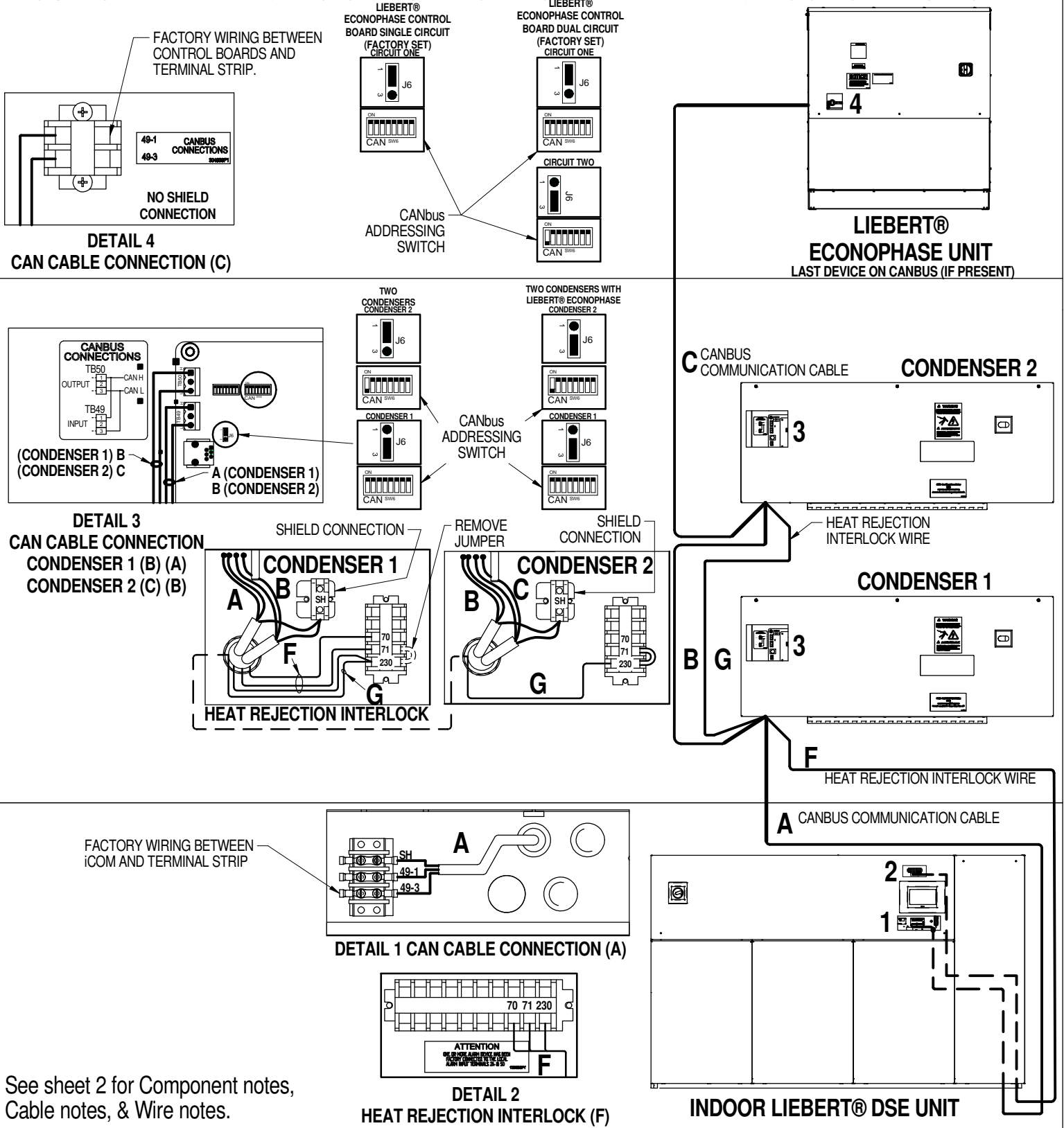

See sheet 2 for Component notes, Cable notes, & Wire notes.

Form No. - DPN001040_REV14



LIEBERT® DSE

CANbus & INTERLOCK CONNECTIONS

USING 2 LIEBERT® MC UNITS W/ OPTIONAL LIEBERT® ECONOPHASE UNIT

COMPONENT NOTES:

1. COMPONENT APPEARANCE, ORIENTATION, AND POSITION MAY VARY BETWEEN PRODUCT LINES. TERMINAL NAMES AND CALLOUTS REMAIN CONSTANT.
2. ALL CIRCUITS TO THESE CONNECTION POINTS ARE CLASS 2.

CAN & CABLE NOTES (A, B, C):

1. CABLE MUST HAVE THE FOLLOWING SPECIFICATIONS:

- BRAIDED SHIELD OR FOIL SHIELD WITH DRAIN WIRE
 - SHIELD MUST BE WIRED TO GROUND AT INDOOR UNIT
 - 22-18AWG STRANDED TINNED COPPER
 - TWISTED PAIR (MINIMUM 4 TWISTS PER FOOT)
 - LOW CAPACITANCE (15pF/FT OR LESS)
 - MUST BE RATED TO MEET LOCAL CODES AND CONDITIONS.
 - EXAMPLES BELDEN 89207 (PLENUM RATED), OR ALPHA WIRE 6454 CATEGORY 5, 5E, OR HIGHER.
2. DO NOT RUN IN SAME CONDUIT, RACEWAY, OR CHASE AS HIGH VOLTAGE WIRING.
 3. FOR CANBUS NETWORK LENGTHS GREATER THAN 450FT (137M), CONTACT VERTIV FACTORY.

INTERLOCK WIRE NOTES (F):

1. FIELD SUPPLIED WIRE
 - 3 CONDUCTOR 18AWG OR GREATER
 - RATED 600V
2. RUN FIELD SUPPLIED WIRES BETWEEN THE INDOOR UNIT AND CONDENSER 1.

INTERLOCK WIRE NOTES (G):

1. FIELD SUPPLIED WIRE
 - MINIMUM 1 CONDUCTOR 18AWG OR GREATER
 - RATED 600V
2. RUN FIELD SUPPLIED WIRES BETWEEN CONDENSER 1 AND CONDENSER 2.

CANbus & INTERLOCK CONNECTIONS BETWEEN LIEBERT® DS & LIEBERT® MC (PREMIUM)

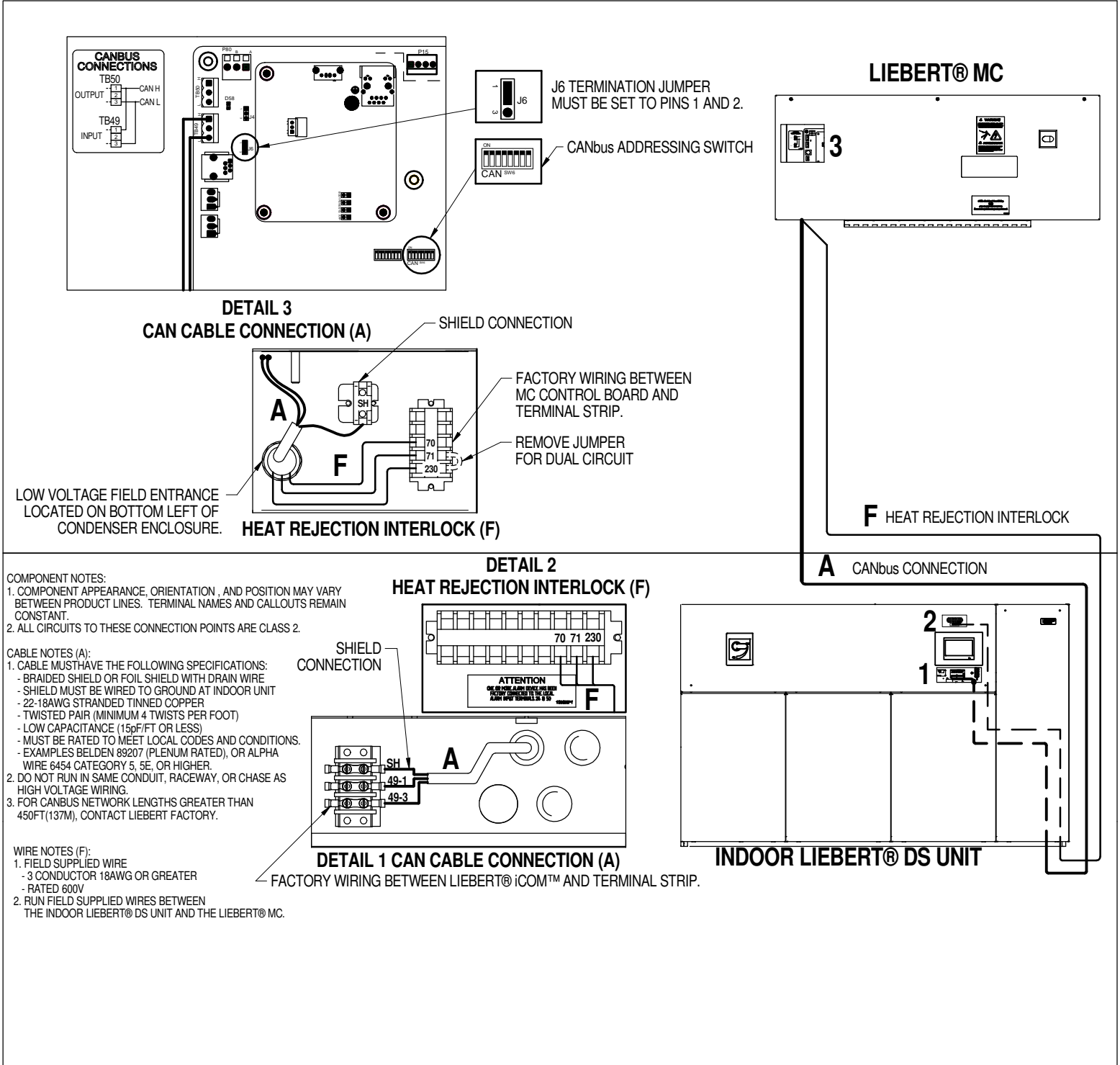

CANbus & INTERLOCK CONNECTIONS BETWEEN 600mm (24in.) UNIT & LIEBERT® MC (PREMIUM)

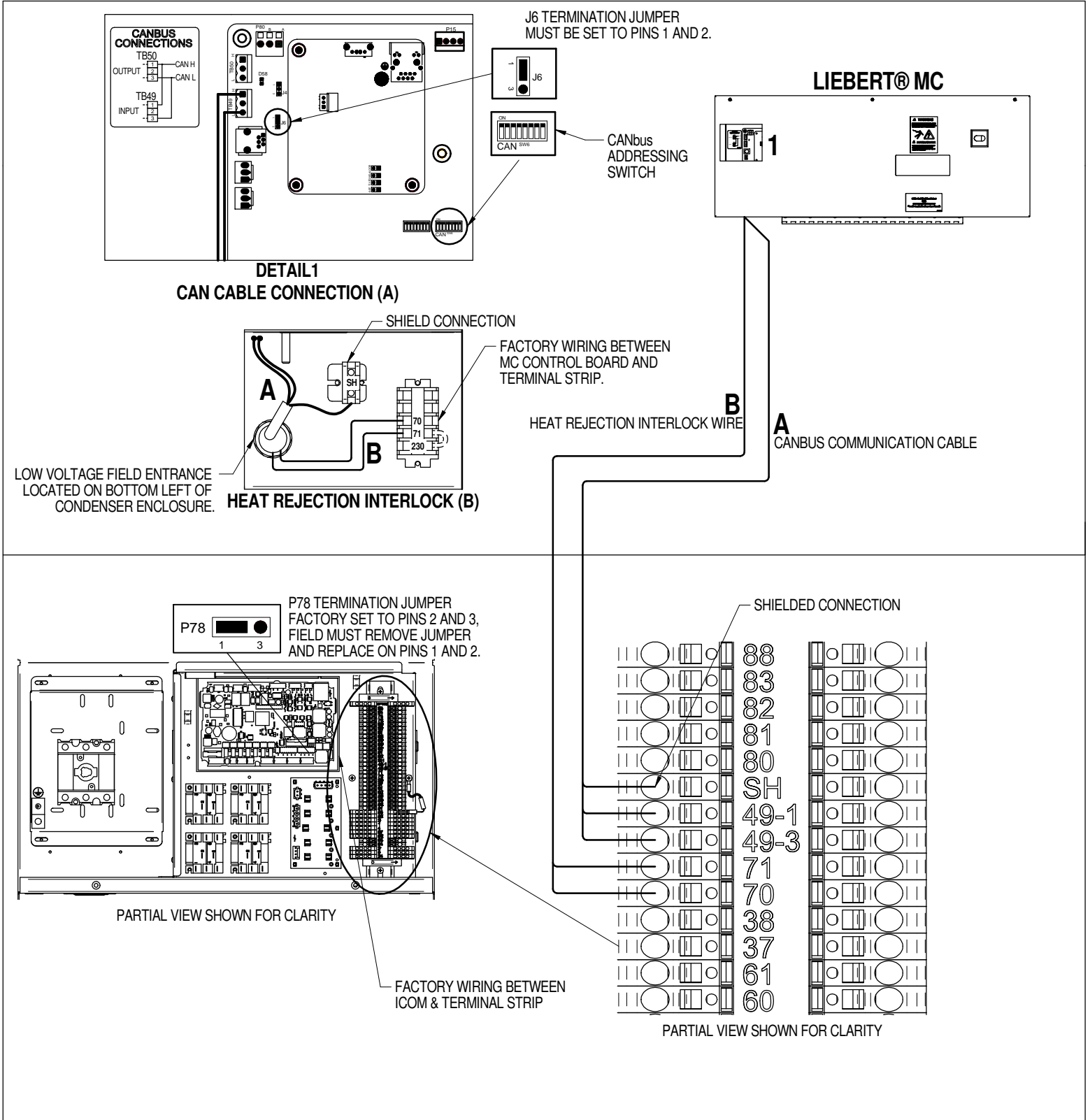



LIEBERT® CRV

CANbus & INTERLOCK CONNECTIONS BETWEEN 600mm (24in.) UNIT & LIEBERT® MC (PREMIUM)

COMPONENT NOTES:

1. COMPONENT APPEARANCE, ORIENTATION, AND POSITION MAY VARY
TERMINAL NAMES AND CALLOUTS REMAIN CONSTANT.
2. ALL CIRCUITS TO THESE CONNECTION POINTS ARE CLASS 2.

CAN & CABLE NOTES (A):

1. CABLE MUST HAVE THE FOLLOWING SPECIFICATIONS:
 - BRAIDED SHIELD OR FOIL SHIELD WITH DRAIN WIRE
 - SHIELD MUST BE WIRED TO GROUND AT INDOOR UNIT
 - 22-18AWG STRANDED TINNED COPPER
 - TWISTED PAIR (MINIMUM 4 TWISTS PER FOOT)
 - LOW CAPACITANCE (15pF/FT OR LESS)
 - MUST BE RATED TO MEET LOCAL CODES AND CONDITIONS.
 - EXAMPLES BELDEN 89207 (PLENUM RATED), OR ALPHA WIRE 6454 CATEGORY 5, 5E, OR HIGHER.
2. DO NOT RUN IN SAME CONDUIT, RACEWAY, OR CHASE AS HIGH VOLTAGE WIRING.
3. FOR CANBUS NETWORK LENGTHS GREATER THAN 450FT(137M), CONTACT FACTORY.

INTERLOCK WIRE NOTES (B):

1. FIELD SUPPLIED WIRE
 - 2 CONDUCTOR 18AWG OR GREATER
 - RATED 600V
2. RUN FIELD SUPPLIED WIRES BETWEEN THE INDOOR UNIT AND THE CONDENSER.

CANbus & INTERLOCK CONNECTIONS BETWEEN 300mm (12in.) UNIT & LIEBERT® MC (PREMIUM)

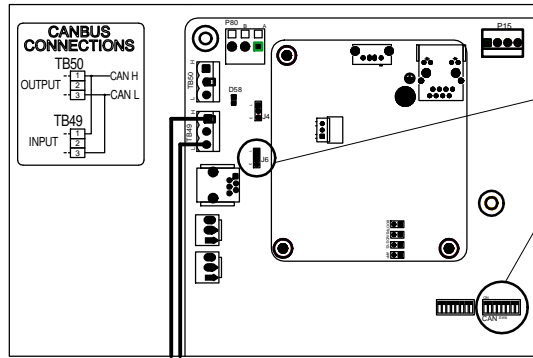

**DETAIL1
CAN CABLE CONNECTION (A)**

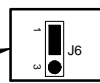

J6 TERMINATION JUMPER
MUST BE SET TO PINS 1 AND 2.

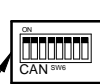

CANbus
ADDRESSING
SWITCH

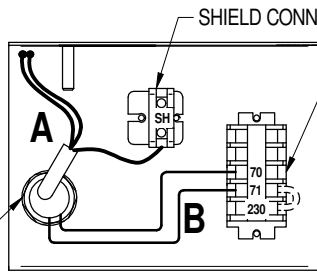
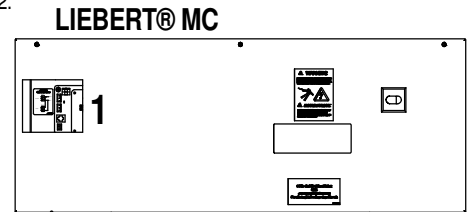

LOW VOLTAGE FIELD ENTRANCE
LOCATED ON BOTTOM LEFT OF
CONDENSER ENCLOSURE.

HEAT REJECTION INTERLOCK (B)

SHIELD CONNECTION

FACTORY WIRING BETWEEN
MC CONTROL BOARD AND
TERMINAL STRIP.

HEAT REJECTION INTERLOCK

LIEBERT® MC

1

A CANbus CABLE CONNECTION

COMPONENT NOTES:

1. COMPONENT APPEARANCE, ORIENTATION AND POSITIONING MAY VARY. TERMINAL NAMES AND CALLOUTS REMAIN CONSTANT.
2. ALL CIRCUITS TO THESE CONNECTION POINTS ARE CLASS 2.

CAN & CABLE NOTES (A):

1. CABLE MUST HAVE THE FOLLOWING SPECIFICATIONS:
 - BRAIDED SHIELD OR FOIL SHIELD WITH DRAIN WIRE
 - SHIELD MUST BE WIRED TO GROUND AT INDOOR UNIT
 - 22-18AWG STRANDED TINNED COPPER
 - TWISTED PAIR (MINIMUM 4 TWISTS PER FOOT)
 - LOW CAPACITANCE (15pF/FT OR LESS)
 - MUST BE RATED TO MEET LOCAL CODES AND CONDITIONS.
 - EXAMPLES BELDEN 89207 (PLENUM RATED), OR ALPHA WIRE 6454 CATEGORY 5, 5E, OR HIGHER.
2. DO NOT RUN IN SAME CONDUIT, RACEWAY, OR CHASE AS HIGH VOLTAGE WIRING.
3. FOR CANBUS NETWORK LENGTHS GREATER THAN 450FT(137M) CONTACT FACTORY.

INTERLOCK WIRE NOTES (B):

1. FIELD SUPPLIED WIRE
 - 2 CONDUCTOR 18AWG OR GREATER
 - RATED 600V
2. RUN FIELD SUPPLIED WIRES BETWEEN THE INDOOR UNIT AND THE CONDENSER.

CRV300 INDOOR UNIT

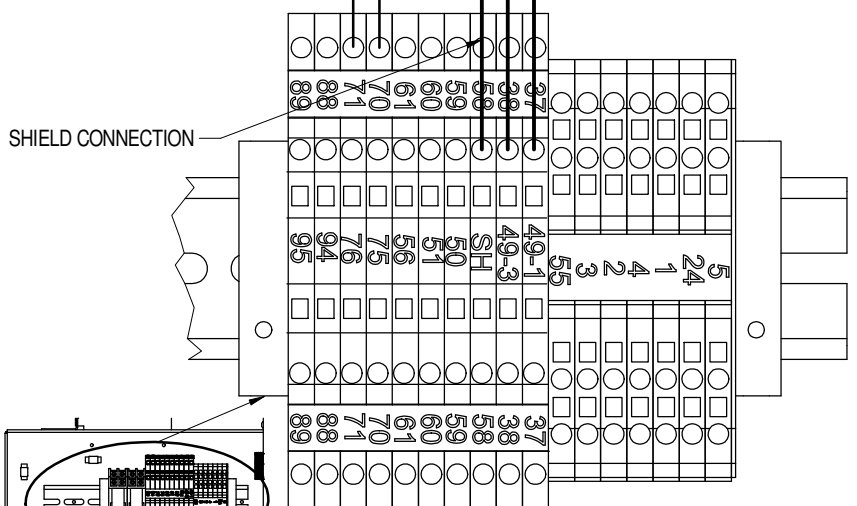

SHIELD CONNECTION

PARTIAL VIEW SHOWN FOR CLARITY

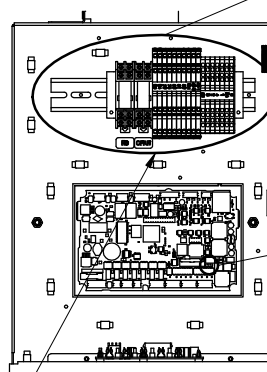

FACTORY WIRING BETWEEN ICOM AND TERMINAL STRIP.

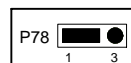

P78 TERMINATION JUMPER
FACTORY SET TO PINS 2 AND 3,
FIELD MUST REMOVE JUMPER
AND REPLACE ON PINS 1 AND 2.

CANbus & INTERLOCK CONNECTIONS BETWEEN LIEBERT® PDX UNIT & LIEBERT® MC CONDENSER (PREMIUM)

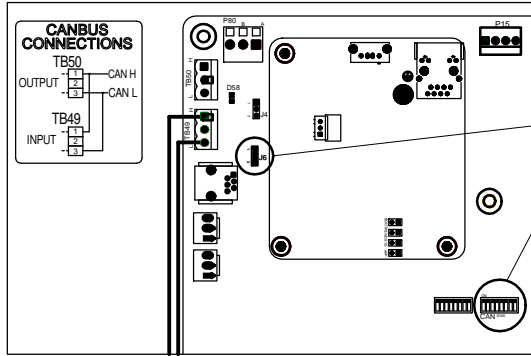

**DETAIL 1
CAN CABLE CONNECTION (A)**

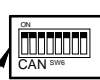
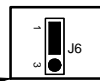

J6 TERMINATION JUMPER
MUST BE SET TO PINS 1 AND 2.

CANbus ADDRESSING SWITCH

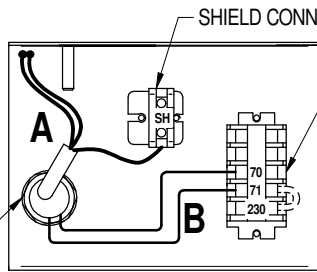
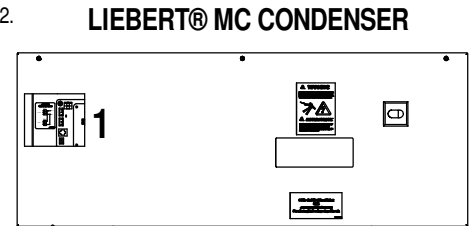

HEAT REJECTION INTERLOCK (B)

CANbus CABLE CONNECTION

**B
HEAT REJECTION INTERLOCK WIRE**

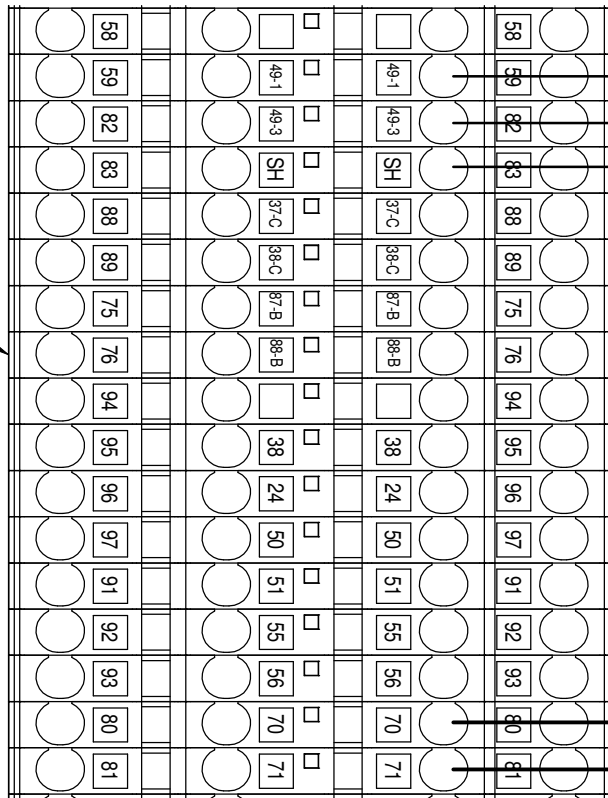
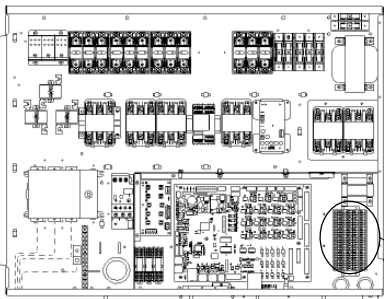

PARTIAL VIEW SHOWN FOR CLARITY



LIEBERT® PDX

CANbus & INTERLOCK CONNECTIONS BETWEEN LIEBERT® PDX UNIT & LIEBERT® MC CONDENSER (PREMIUM)

COMPONENT NOTES:

1. COMPONENT APPEARANCE, ORIENTATION AND POSITIONING MAY VARY TERMINAL NAMES AND CALLOUTS REMAIN CONSTANT.
2. ALL CIRCUITS TO THESE CONNECTION POINTS ARE CLASS 2.

CAN & CABLE NOTES (A):

1. CABLE MUST HAVE THE FOLLOWING SPECIFICATIONS:
 - BRAIDED SHIELD OR FOIL SHIELD WITH DRAIN WIRE
 - SHIELD MUST BE WIRED TO GROUND AT INDOOR UNIT
 - 22-18AWG STRANDED TINNED COPPER
 - TWISTED PAIR (MINIMUM 4 TWISTS PER FOOT)
 - LOW CAPACITANCE (15pF/FT OR LESS)
 - MUST BE RATED TO MEET LOCAL CODES AND CONDITIONS.
 - EXAMPLES BELDEN 89207 (PLENUM RATED), OR ALPHA WIRE 6454 CATEGORY 5, 5E, OR HIGHER.
2. DO NOT RUN IN SAME CONDUIT, RACEWAY, OR CHASE AS HIGH VOLTAGE WIRING.
3. FOR CANBUS NETWORK LENGTHS GREATER THAN 450FT(137M), CONTACT FACTORY.

INTERLOCK WIRE NOTES (B):

1. FIELD SUPPLIED WIRE
 - 2 CONDUCTOR 18AWG OR GREATER
 - RATED 600V
2. RUN FIELD SUPPLIED WIRES BETWEEN THE INDOOR UNIT AND THE CONDENSER.

ELECTRICAL: 575V OPTION

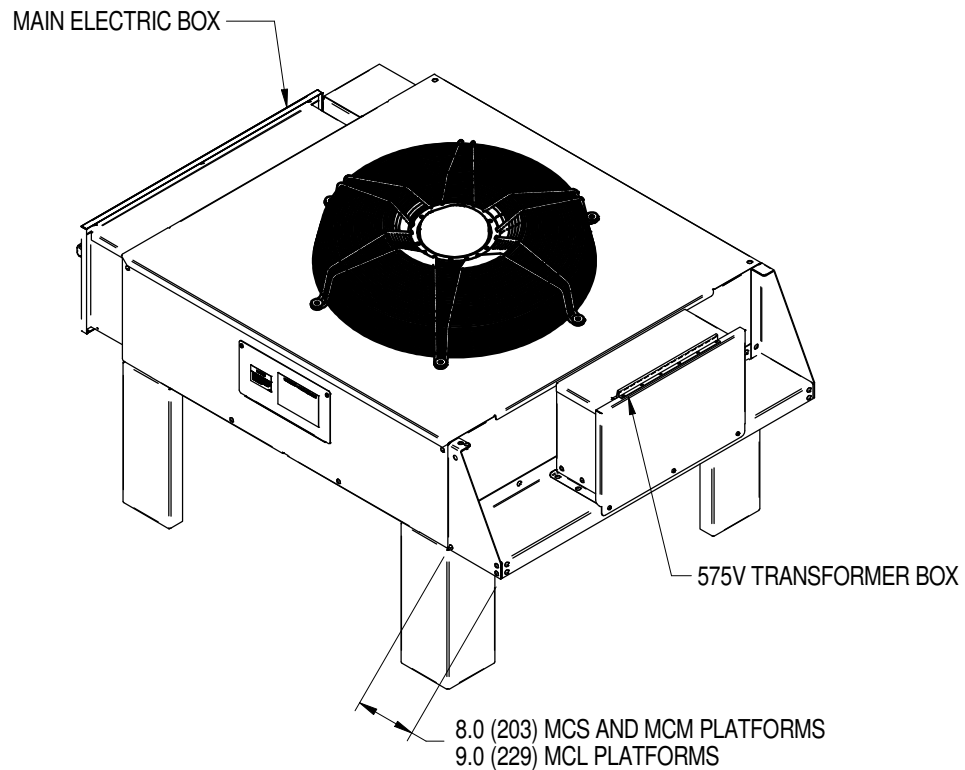

- CUSTOMER FIELD CONNECTIONS MADE IN MAIN ELECTRIC BOX.
- POWER DISCONNECT LOCATED IN MAIN ELECTRIC BOX.
- TRANSFORMER BOX IS FACTORY WIRED TO MAIN ELECTRIC BOX.
- 575V TRANSFORMER BOX INCLUDES TRANSFORMER AND PROTECTIVE FUSES FOR TRANSFORMER SECONDARY.



VERTIV™

Installation Instructions for Installing 420 Surge Protective Device (SPD) to Liebert® MC

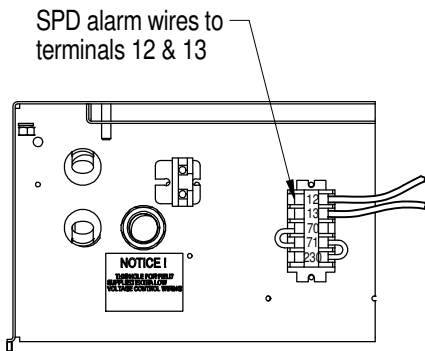
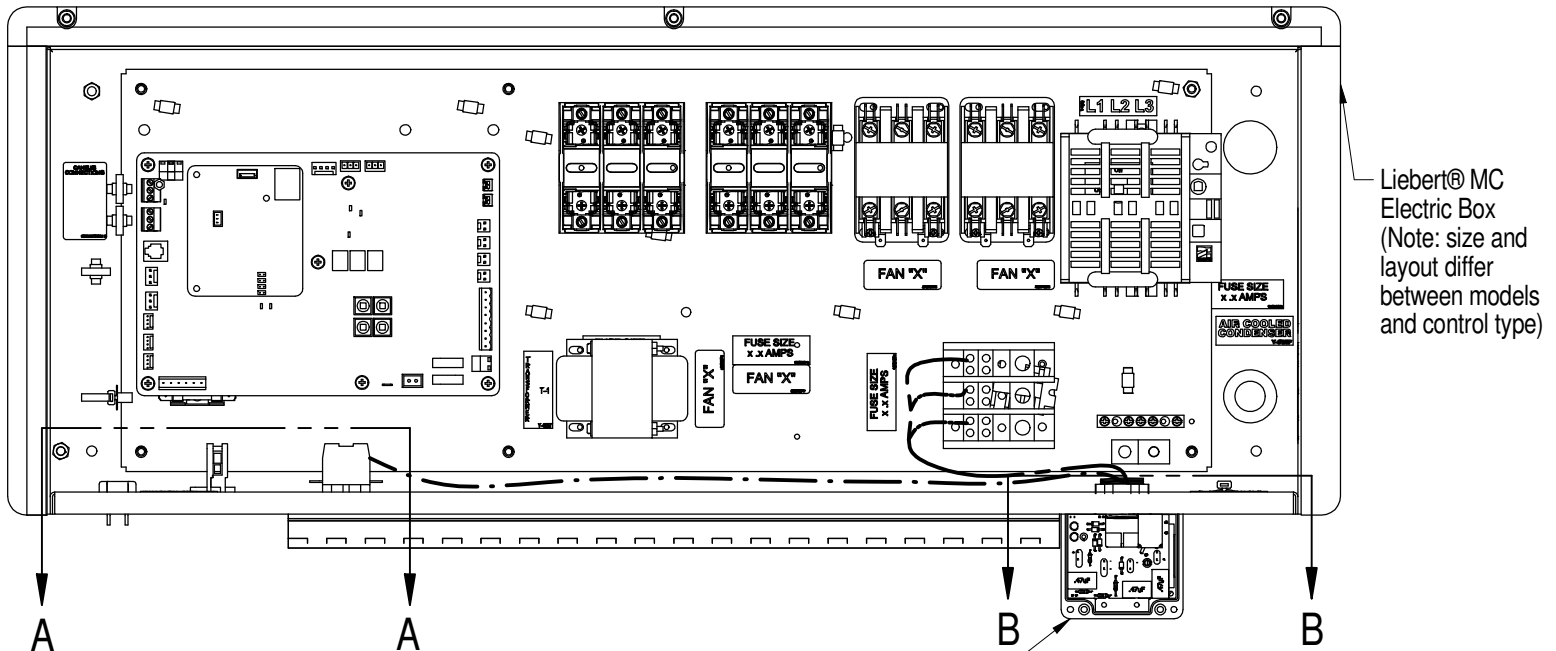

SECTION A-A

The SPD is mounted through the leftmost knockout hole in the bottom of the Electric Box

Phase wires from SPD to load side of Power Block

Orange & Yellow wires from SPD to terminals 12 & 13

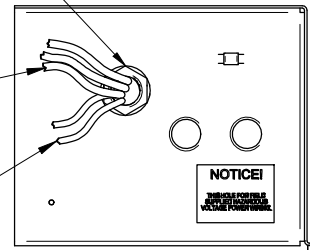

SECTION B-B

! WARNING: Risk of arc flash and electrical shock! Can cause injury or death!

Open all local and remote electric power supply disconnect switches, verify with a voltmeter that power is off, and wear personal protective equipment per NFPA 70 E before working within the electrical control enclosure or performing any electrical and/or mechanical service and/or maintenance operations. The variable speed control may contain a stored electrical charge. Disconnect all local and remote electrical power supplies and wait 10 minutes before working within the condenser's main electrical enclosure or fan electrical enclosure. The Liebert® MC contains lethal voltage in some circuits. The line side of the disconnect remains energized when the condenser unit disconnect is switched to the OFF position.

1. Verify the incoming voltage matches the rated voltage of the Surge Protective Device (SPD).
2. Use the leftmost knockout on the right side of the electrical box bottom (see section B-B above) or drill a 7/8" hole to attach the 420 SPD.
3. Remove the coupler nut from the SPD, but leave the o-ring on the threaded coupler. Pass the wires and threaded coupler through the knockout hole, and pass the wires through the coupler nut. Orient the SPD so the clear cover is visible from the Liebert® MC front.
4. Hold the SPD up while tightening the coupler nut to compress the o-ring (approximately 10 in-lbs).
5. Attach the SPD green wire to the earth ground connection.
6. Trim the SPD black phase wires to the minimum length required to reach the power block.
7. Attach the SPD black phase wires to the load side of the power block (see schematic) (approximately 7 in-lbs).
Note: The SPD black phase wires are NOT phase dependent. (It does not matter which black wire is connected to L1, L2, or L3.)
8. Attach the SPD orange & yellow wires to terminal connections 12 & 13 respectively (see Section A-A) (approximately 16 in-lbs).

SEISMIC ANCHORAGE DATA ONE FAN MODELS

Without Receiver

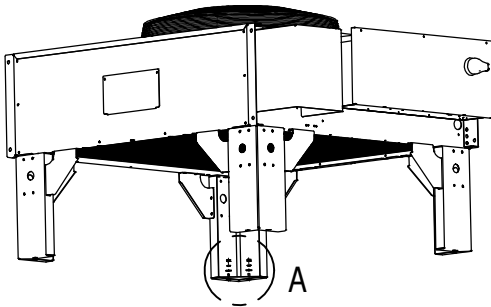

Figure 1

With Receiver
(View shows bracket only.
Receiver removed for clarity)

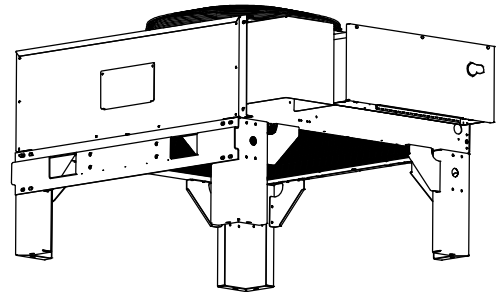
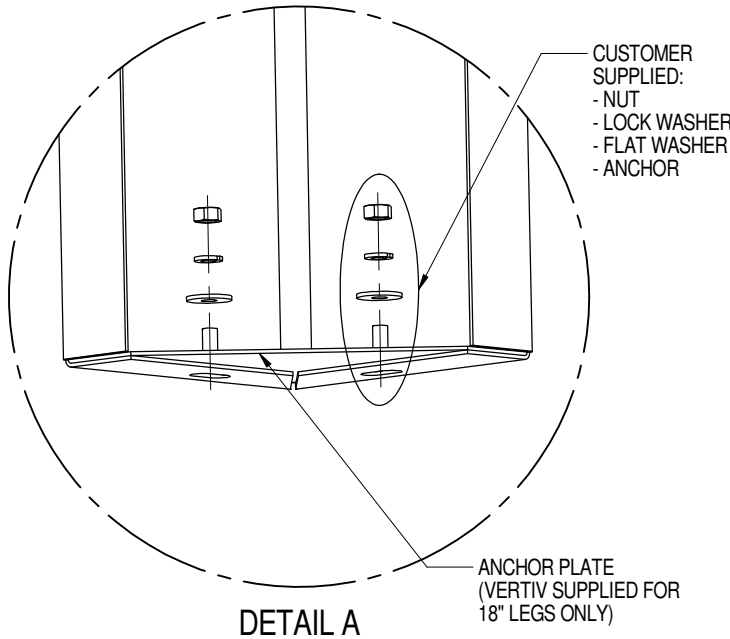

Figure 2



NOTES:

1. MOUNTING REQUIREMENT DETAILS SUCH AS ANCHOR BRAND, TYPE, EMBEDMENT DEPTH, EDGE SPACING, ANCHOR-TO-ANCHOR SPACING, CONCRETE STRENGTH, SPECIAL INSPECTION AND ATTACHMENT TO NON-BUILDING STRUCTURES MUST BE OUTLINED AND APPROVED BY THE ENGINEER OF RECORD FOR THE PROJECT OR BUILDING. STRUCTURAL FLOORS AND HOUSEKEEPING PADS MUST ALSO BE SEISMICALLY DESIGNED AND APPROVED BY THE PROJECT OR BUILDING STRUCTURAL ENGINEER OF RECORD TO WITHSTAND THE SEISMIC ANCHOR LOADS DEFINED IN THE TABLE BELOW. THE INSTALLING CONTRACTOR IS RESPONSIBLE FOR THE PROPER INSTALLATION OF ALL ANCHORS AND MOUNTING HARDWARE, OBSERVING THE MOUNTING REQUIREMENTS DETAILED IN THE SEISMIC INSTALLATION DRAWINGS AND ADDITIONALLY OUTLINED BY THE ENGINEER OF RECORD.
2. ALL BRACES AND FASTENERS ARE REQUIRED TO MAINTAIN IBC/OSHPD CERTIFICATION OF CONFORMITY.
3. USE WASHER, LOCK WASHER AND SCREW TO CONNECT BRACE TO CONDENSER BOTTOM BEAM (SEE SHEET 2).
4. USE WASHER, LOCK WASHER, SCREW AND NUT TO CONNECT BRACE TO CONDENSER LEG (SEE SHEET 2).
5. PLACE ANCHORAGE PLATE INSIDE EACH CONDENSER FOOT PRIOR TO FASTENING TO THE STRUCTURE. USE FLAT WASHER, LOCK WASHER AND NUT TO CONNECT CONDENSER TO THE CUSTOMER SUPPLIED ANCHOR ON THE SOLID SURFACE (REFERENCE VIEW DETAIL A). AS A MINIMUM 3/8" GRADE ANCHORS WITH AMERICAN NATIONAL STANDARD SERIES W, TYPE A, PLAIN WASHERS (ANSI B18.22.1-1965, R1975) SELECTED TO MATCH THE NOMINAL ANCHOR DIAMETER MUST BE INSTALLED AT EACH ANCHOR LOCATION BETWEEN THE ANCHOR HEAD AND EQUIPMENT FOR TENSION LOAD DISTRIBUTION.

MODEL	FIGURE	IMPORTANCE FACTOR $I_p = 1.0$			IMPORTANCE FACTOR $I_p = 1.5$		
		MAXIMUM COMPRESSIVE REACTION	MAX. ANCHOR LOADS (ASD)		MAXIMUM COMPRESSIVE REACTION	MAX. ANCHOR LOADS (ASD)	
			TENSILE	SHEAR		TENSILE	SHEAR
		lbs.	lbs.	lbs.	lbs.	lbs.	
MCS028							
WITHOUT RECEIVER	1	37	14	14	47	24	21
WITH RECEIVER	2	43	15	23	56	27	35
MCM040							
WITHOUT RECEIVER	1	37	14	14	47	24	21
WITH RECEIVER	2	43	15	23	56	27	35
MCL055							
WITHOUT RECEIVER	1	37	14	14	47	24	21
WITH RECEIVER	2	43	15	23	56	27	35

* ALL LOADS ARE CALCULATED PER ASCE 7-05, CHAPTER 13.6 $S_d=2.0$, $R_p=6.0$, $a=2.5$

SEISMIC ANCHORAGE DATA TWO FAN MODELS

WITHOUT RECEIVER

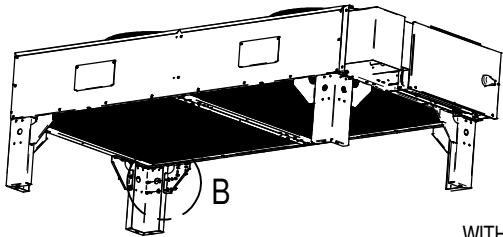

FIGURE 3

WITH RECEIVER
(VIEWS SHOW RECEIVER BRACKET ONLY.
RECEIVERS NOT SHOWN FOR CLARITY)

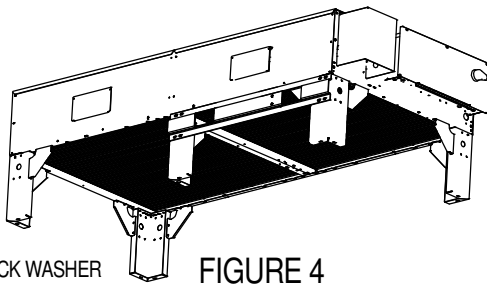
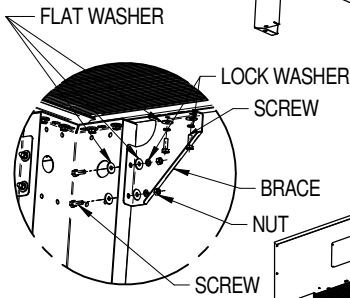

FIGURE 4



DETAIL B

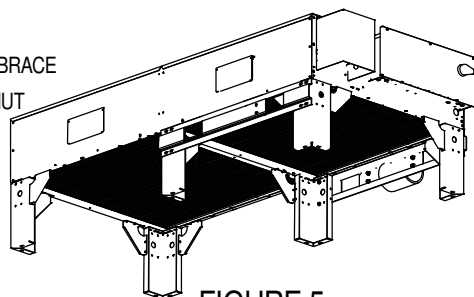

FIGURE 5

NOTES:

1. MOUNTING REQUIREMENT DETAILS SUCH AS ANCHOR BRAND, TYPE, EMBEDMENT DEPTH, EDGE SPACING, ANCHOR-TO-ANCHOR SPACING, CONCRETE STRENGTH, SPECIAL INSPECTION AND ATTACHMENT TO NON-BUILDING STRUCTURES MUST BE OUTLINED AND APPROVED BY THE ENGINEER OF RECORD FOR THE PROJECT OR BUILDING. STRUCTURAL FLOORS AND HOUSEKEEPING PADS MUST ALSO BE SEISMICALLY DESIGNED AND APPROVED BY THE PROJECT OR BUILDING STRUCTURAL ENGINEER OF RECORD TO WITHSTAND THE SEISMIC ANCHOR LOADS DEFINED IN THE TABLE BELOW. THE INSTALLING CONTRACTOR IS RESPONSIBLE FOR THE PROPER INSTALLATION OF ALL ANCHORS AND MOUNTING HARDWARE, OBSERVING THE MOUNTING REQUIREMENTS DETAILED IN THE SEISMIC INSTALLATION DRAWINGS AND ADDITIONALLY OUTLINED BY THE ENGINEER OF RECORD.
2. ALL BRACES AND FASTENERS ARE REQUIRED TO MAINTAIN IBC/OSHPD CERTIFICATION OF CONFORMITY.
3. USE WASHER, LOCK WASHER AND SCREW TO CONNECT BRACE TO CONDENSER BOTTOM BEAM (REFERENCE VIEW DETAIL B).
4. USE WASHER, LOCK WASHER, SCREW AND NUT TO CONNECT BRACE TO CONDENSER LEG (REFERENCE VIEW DETAIL B).
5. PLACE ANCHORAGE PLATE INSIDE EACH CONDENSER FOOT PRIOR TO FASTENING TO THE STRUCTURE. USE FLAT WASHER, LOCK WASHER AND NUT TO CONNECT CONDENSER TO THE CUSTOMER SUPPLIED ANCHOR ON THE SOLID SURFACE (SEE SHEET 1). AS A MINIMUM 3/8" GRADE ANCHORS WITH AMERICAN NATIONAL STANDARD SERIES W, TYPE A, PLAIN WASHERS (ANSI B18.22.1-1965, R1975) SELECTED TO MATCH THE NOMINAL ANCHOR DIAMETER MUST BE INSTALLED AT EACH ANCHOR LOCATION BETWEEN THE ANCHOR HEAD AND EQUIPMENT FOR TENSION LOAD DISTRIBUTION.

MODEL	FIGURE	IMPORTANCE FACTOR $I_p = 1.0$			IMPORTANCE FACTOR $I_p = 1.5$		
		MAXIMUM COMPRESSIVE REACTION Lbs.	MAX. ANCHOR LOADS (ASD)		MAXIMUM COMPRESSIVE REACTION Lbs.	MAX. ANCHOR LOADS (ASD)	
			TENSILE	SHEAR		TENSILE	SHEAR
			lbs.	lbs.		lbs.	lbs.
MCS056							
WITHOUT RECEIVER	3	63	20	23	78	35	34
WITH RECEIVER	5	69	15	30	75	30	35
MCM080							
SINGLE OR DUAL CIRCUIT WITHOUT RECEIVER	3	94	30	34	116	53	50
SINGLE CIRCUIT WITH RECEIVER	4	87	34	38	99	59	57
DUAL CIRCUIT WITH RECEIVER	5	90	24	38	98	44	57
MCL110							
SINGLE OR DUAL CIRCUIT WITHOUT RECEIVER	3	146	42	55	179	76	82
SINGLE CIRCUIT WITH RECEIVER	4	131	47	53	158	83	80
DUAL CIRCUIT WITH RECEIVER	5	117	31	51	136	59	77

* ALL LOADS ARE CALCULATED PER ASCE 7-05, CHAPTER 13.6 $S_{ds}=2.0$, $R_p=6.0$, $a=2.5$

**SEISMIC ANCHORAGE DATA
THREE FAN MODELS**

WITHOUT RECEIVER

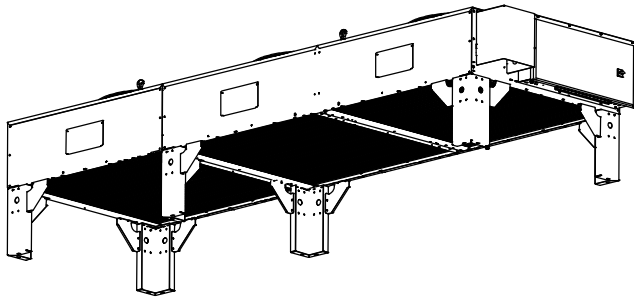

FIGURE 6

WITH RECEIVER
(VIEWS SHOW RECEIVER BRACKET ONLY.
RECEIVER NOT SHOWN FOR CLARITY.)

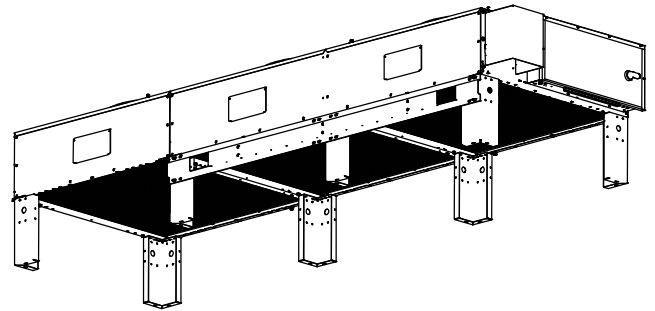

FIGURE 7

NOTES:

1. MOUNTING REQUIREMENT DETAILS SUCH AS ANCHOR BRAND, TYPE, EMBEDMENT DEPTH, EDGE SPACING, ANCHOR-TO-ANCHOR SPACING, CONCRETE STRENGTH, SPECIAL INSPECTION AND ATTACHMENT TO NON-BUILDING STRUCTURES MUST BE OUTLINED AND APPROVED BY THE ENGINEER OF RECORD FOR THE PROJECT OR BUILDING. STRUCTURAL FLOORS AND HOUSEKEEPING PADS MUST ALSO BE SEISMICALLY DESIGNED AND APPROVED BY THE PROJECT OR BUILDING STRUCTURAL ENGINEER OF RECORD TO WITHSTAND THE SEISMIC ANCHOR LOADS DEFINED IN THE TABLE BELOW. THE INSTALLING CONTRACTOR IS RESPONSIBLE FOR THE PROPER INSTALLATION OF ALL ANCHORS AND MOUNTING HARDWARE, OBSERVING THE MOUNTING REQUIREMENTS DETAILED IN THE SEISMIC INSTALLATION DRAWINGS AND ADDITIONALLY OUTLINED BY THE ENGINEER OF RECORD.
2. ALL BRACES AND FASTENERS ARE REQUIRED TO MAINTAIN IBC/OSHPD CERTIFICATION OF CONFORMITY.
3. USE WASHER, LOCK WASHER AND SCREW TO CONNECT BRACE TO CONDENSER BOTTOM BEAM (SEE SHEET 2).
4. USE WASHER, LOCK WASHER, SCREW AND NUT TO CONNECT BRACE TO CONDENSER LEG (SEE SHEET 2).
5. PLACE ANCHORAGE PLATE INSIDE EACH CONDENSER FOOT PRIOR TO FASTENING TO THE STRUCTURE. USE FLAT WASHER, LOCK WASHER AND NUT TO CONNECT CONDENSER TO THE CUSTOMER SUPPLIED ANCHOR ON THE SOLID SURFACE (SEE SHEET 1). AS A MINIMUM 3/8" GRADE ANCHORS WITH AMERICAN NATIONAL STANDARD SERIES W, TYPE A, PLAIN WASHERS (ANSI B18.22.1-1965, R1975) SELECTED TO MATCH THE NOMINAL ANCHOR DIAMETER MUST BE INSTALLED AT EACH ANCHOR LOCATION BETWEEN THE ANCHOR HEAD AND EQUIPMENT FOR TENSION LOAD DISTRIBUTION.

MODEL	FIGURE	IMPORTANCE FACTOR $I_p = 1.0$			IMPORTANCE FACTOR $I_p = 1.5$		
		MAXIMUM COMPRESSIVE REACTION Lbs.	MAX. ANCHOR LOADS (ASD)		MAXIMUM COMPRESSIVE REACTION Lbs.	MAX. ANCHOR LOADS (ASD)	
			TENSILE	SHEAR		TENSILE	SHEAR
		lbs.	lbs.		lbs.	lbs.	
MCL165							
SINGLE CIRCUIT WITHOUT RECEIVER	6	158	39	62	181	73	93
SINGLE CIRCUIT WITH RECEIVER	7	153	38	65	170	73	97

* ALL LOADS ARE CALCULATED PER ASCE 7-05, CHAPTER 13.6 $S_{ds}=2.0$, $R_p=6.0$, $a=2.5$

**SEISMIC ANCHORAGE DATA
FOUR FAN MODELS**

WITHOUT RECEIVER

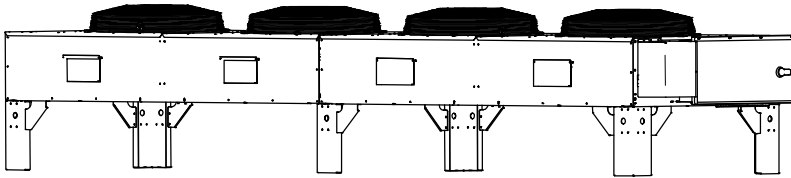

FIGURE 8

WITH RECEIVER
(VIEWS SHOWN WITH RECEIVER BRACKET ONLY.
RECEIVER NOT SHOWN FOR CLARITY.)

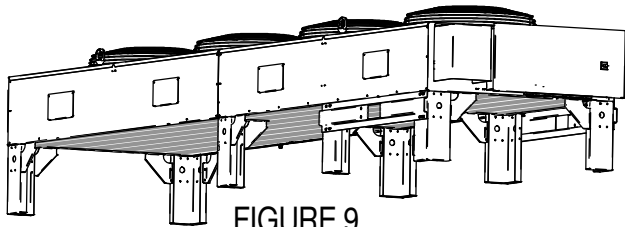

FIGURE 9

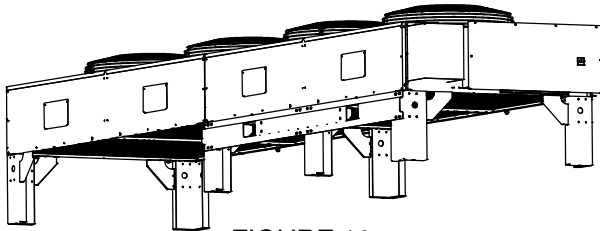

FIGURE 10

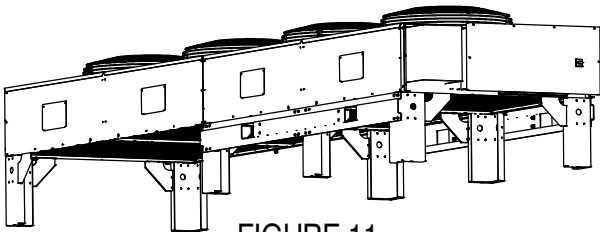

FIGURE 11

NOTES:

1. MOUNTING REQUIREMENT DETAILS SUCH AS ANCHOR BRAND, TYPE, EMBEDMENT DEPTH, EDGE SPACING, ANCHOR-TO-ANCHOR SPACING, CONCRETE STRENGTH, SPECIAL INSPECTION AND ATTACHMENT TO NON-BUILDING STRUCTURES MUST BE OUTLINED AND APPROVED BY THE ENGINEER OF RECORD FOR THE PROJECT OR BUILDING. STRUCTURAL FLOORS AND HOUSEKEEPING PADS MUST ALSO BE SEISMICALLY DESIGNED AND APPROVED BY THE PROJECT OR BUILDING STRUCTURAL ENGINEER OF RECORD TO WITHSTAND THE SEISMIC ANCHOR LOADS DEFINED IN THE TABLE BELOW. THE INSTALLING CONTRACTOR IS RESPONSIBLE FOR THE PROPER INSTALLATION OF ALL ANCHORS AND MOUNTING HARDWARE, OBSERVING THE MOUNTING REQUIREMENTS DETAILED IN THE SEISMIC INSTALLATION DRAWINGS AND ADDITIONALLY OUTLINED BY THE ENGINEER OF RECORD.
2. ALL BRACES AND FASTENERS ARE REQUIRED TO MAINTAIN IBC/OSHPD CERTIFICATION OF CONFORMITY.
3. USE WASHER, LOCK WASHER AND SCREW TO CONNECT BRACE TO CONDENSER BOTTOM BEAM (SEE SHEET 2).
4. USE WASHER, LOCK WASHER, SCREW AND NUT TO CONNECT BRACE TO CONDENSER LEG (SEE SHEET 2).
5. PLACE ANCHORAGE PLATE INSIDE EACH CONDENSER FOOT PRIOR TO FASTENING TO THE STRUCTURE. USE FLAT WASHER, LOCK WASHER AND NUT TO CONNECT CONDENSER TO THE CUSTOMER SUPPLIED ANCHOR ON THE SOLID SURFACE (SEE SHEET 1). AS A MINIMUM 3/8" GRADE ANCHORS WITH AMERICAN NATIONAL STANDARD SERIES W, TYPE A, PLAIN WASHERS (ANSI B18.22.1-1965, R1975) SELECTED TO MATCH THE NOMINAL ANCHOR DIAMETER MUST BE INSTALLED AT EACH ANCHOR LOCATION BETWEEN THE ANCHOR HEAD AND EQUIPMENT FOR TENSION LOAD DISTRIBUTION.

MODEL	FIGURE	IMPORTANCE FACTOR $I_p = 1.0$			IMPORTANCE FACTOR $I_p = 1.5$		
		MAXIMUM COMPRESSIVE REACTION Lbs.	MAX. ANCHOR LOADS (ASD)		MAXIMUM COMPRESSIVE REACTION Lbs.	MAX. ANCHOR LOADS (ASD)	
			TENSILE	SHEAR		TENSILE	SHEAR
		lbs.	lbs.	lbs.	lbs.	lbs.	lbs.
MCM160							
DUAL CIRCUIT WITHOUT RECEIVER	8	122	37	42	148	65	62
DUAL CIRCUIT WITH RECEIVER	9	120	33	42	145	59	63
MCL220							
SINGLE OR DUAL CIRCUIT WITHOUT RECEIVER	8	194	53	69	232	95	104
SINGLE CIRCUIT WITH RECEIVER	10	191	51	74	221	92	110
DUAL CIRCUIT WITH RECEIVER	11	176	45	60	211	82	90

* ALL LOADS ARE CALCULATED PER ASCE 7-05, CHAPTER 13.6 $S_{ds}=2.0$, $R_p=6.0$, $a=2.5$

SEISMIC ANCHORAGE DATA 36" - 60" EXTENDED LEG

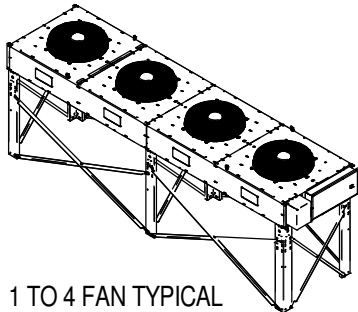

1 TO 4 FAN TYPICAL

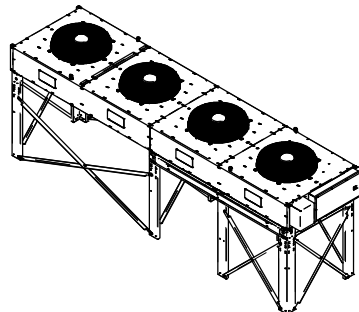

1 TO 4 FAN WITH RECEIVER(S) TYPICAL
RECEIVER MOUNTING BASE SHOWN

INSTRUCTIONS:

1. MOUNTING REQUIREMENT DETAILS SUCH AS ANCHOR BRAND, TYPE, EMBEDMENT DEPTH, EDGE SPACING, ANCHOR-TO-ANCHOR SPACING, CONCRETE STRENGTH, SPECIAL INSPECTION AND ATTACHMENT TO NON-BUILDING STRUCTURES MUST BE OUTLINED AND APPROVED BY THE ENGINEER OF RECORD FOR THE PROJECT OR BUILDING. STRUCTURAL FLOORS AND HOUSEKEEPING PADS MUST ALSO BE SEISMICALLY DESIGNED AND APPROVED BY THE PROJECT OR BUILDING STRUCTURAL ENGINEER OF RECORD TO WITHSTAND THE SEISMIC ANCHOR LOADS DEFINED IN THE TABLE BELOW.
2. ALL BRACES AND FASTENERS ARE REQUIRED TO MAINTAIN IBC/O SHPD CERTIFICATION OF CONFORMITY.
3. USE FLAT WASHER, LOCK WASHER AND NUT TO CONNECT CONDENSER TO THE CUSTOMER SUPPLIED BOLT ON THE SOLID SURFACE (SEE SHEET 1).
4. REFER TO DOCUMENT 308616 FOR ASSEMBLY INSTRUCTION DETAILS.

MODEL	IMPORTANCE FACTOR $I_p = 1.0$			IMPORTANCE FACTOR $I_p = 1.5$		
	MAXIMUM COMPRESSIVE REACTION Lbs.	MAX. ANCHOR LOADS (ASD)		MAXIMUM COMPRESSIVE REACTION Lbs.	MAX. ANCHOR LOADS (ASD)	
		TENSILE lbs.	SHEAR lbs.		TENSILE lbs.	SHEAR lbs.
MCS028 and MCS056						
Single Fan	189	127	31	260	197	46
Single Fan w/ Receiver	234	167	40	328	260	60
Two Fan	251	167	40	344	260	61
Two Fan w/ Receiver	240	175	44	337	273	66
MCM040 Through MCM160						
Single Fan	190	125	32	260	195	48
Single Fan w/ Receiver	238	164	40	329	255	61
Two Fan Single or Dual Circuit	323	218	51	444	339	77
Two Fan Single Circuit w/ Receiver	283	262	53	389	405	79
Two Fan Dual Circuit w/ Receiver	298	218	51	418	339	77
Four Fan Dual Circuit	397	267	62	544	414	93
Four Fan Dual Circuit w/ Receiver	397	276	60	544	428	90
MCL055 Through MCL220						
Single Fan	327	219	56	449	341	84
Single Fan w/ Receiver	372	254	64	514	396	95
Two Fan Single or Dual Circuit	446	287	80	607	448	119
Two Fan Single Circuit w/ Receiver	390	336	73	529	521	110
Two Fan Dual Circuit w/ Receiver	365	256	67	506	395	101
Three Fan Single or Dual Circuit	422	276	78	583	432	118
Three Fan Single Circuit w/ Receiver	370	303	79	506	473	118
Four Fan Single or Dual Circuit	543	351	93	739	548	140
Four Fan Single Circuit w/ Receiver	466	377	94	626	587	141
Four Fan Dual Circuit w/ Receiver	490	328	78	665	510	117

* ALL LOADS ARE CALCULATED PER ASCE 7-05, CHAPTER 13.6 $S_{ds}=2.0$, $R_p=6.0$, $a=2.5$

SEISMIC ANCHORAGE DATA

PIPING & ELECTRICAL WIRING CONSIDERATIONS

SEISMIC PIPING CONSIDERATIONS

Condensers for seismic application, shall be attached to the piping system using field supplied flexible loops designed for seismic movement. Flexible loops shall be capable of movement in three dimensions and must isolate the condenser from field piping. The loops shall be suitable for an operating pressure and temperature of the system. Follow manufacturer's installation instructions for proper seismic application of flexible loops. The selection of isolation brand and type must be outlined and approved by the engineer of record for the project or building.

SEISMIC ELECTRICAL WIRING CONSIDERATIONS

Condensers for seismic application, shall be connected to power and control circuits using field supplied flexible conduit and conductors to allow for movement of the condenser in three dimensions during a seismic event. The flexible conduit shall have at least one bend between the rigid connection at the unit cabinet and the connection to rigid conduit or foundation.

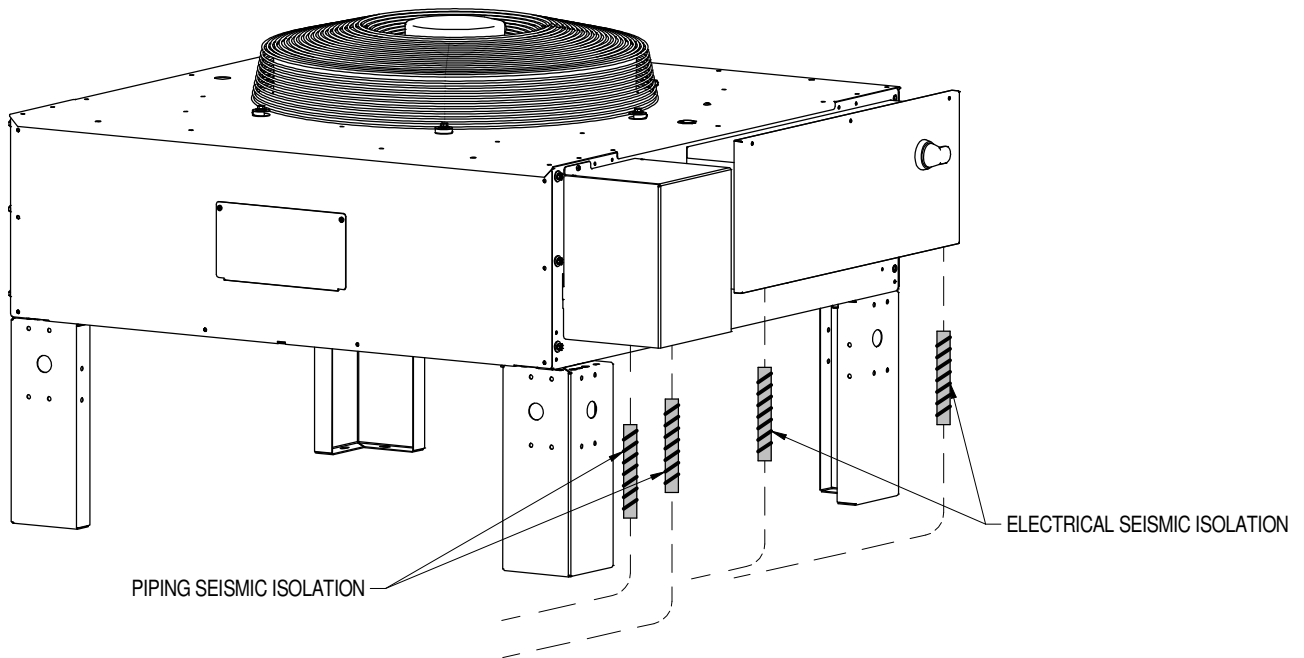

WIND LOAD DATA CERTIFICATION

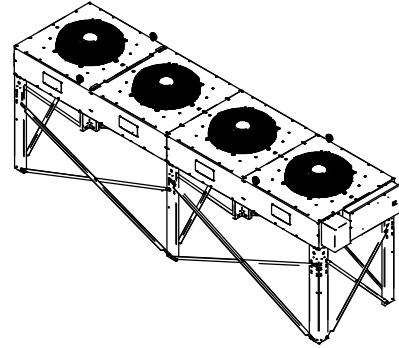
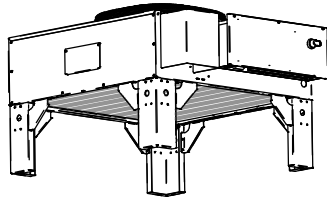

Liebert® MC is self-certified to withstand wind loading in accordance with American Society of Civil Engineers (ASCE) Minimum Design Loads for Buildings and Other Structures, ASCE 7-16. This certification is also in accordance with Florida Building Code 7th Edition, (2020) and the International Building Code (IBC) 2021. The basis for this certification is through successful analytical modeling on the above-mentioned equipment. The certification is valid under site specific wind load criteria where the wind velocity pressure does not exceed those listed in tables 1, 2, 3, and 4. The certification covers leg heights up to 60" with or without receivers. Impact resistance is not covered in this certification.

Mounting requirement details such as anchor brand, type, embedment depth, edge spacing, anchor-to-anchor spacing, concrete strength, special inspection and attachment to non-building structures must be outlined and approved by the engineer of record for the project or building. Structural floors and housekeeping pads must also be designed and approved by the project or building structural engineer of record to withstand the wind anchor loads defined herein. The installing contractor is responsible for the proper installation of all anchors and mounting hardware, observing the mounting requirements detailed in the installation drawings, and additionally outlined by the engineer of record.

**WIND LOAD DATA
ONE FAN, 18" LEG HEIGHT CONFIGURATION**

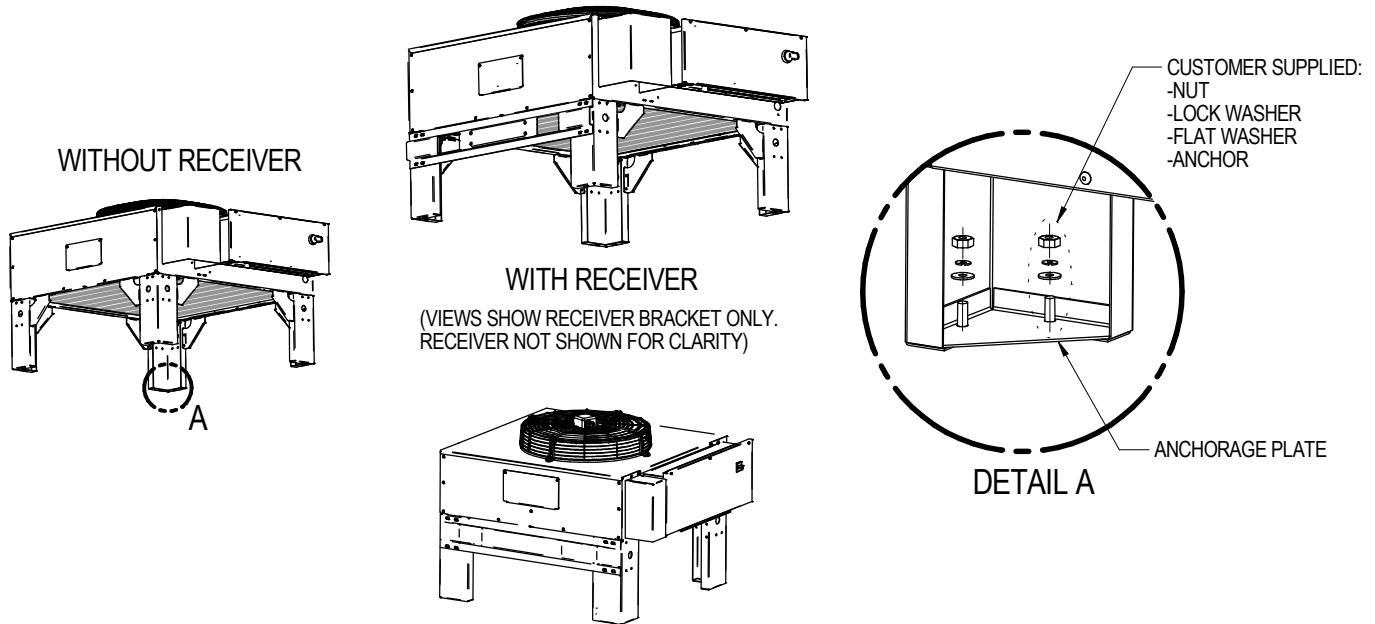

NOTES:

1. All braces and fasteners are required to maintain certification of conformity, see page 2, Detail A and page 3, Detail B.
2. Use washer, lock washer and screw to connect brace to condenser bottom beam (reference view Detail B, page 3).
3. Use washer, lock washer, screw and nut to connect brace to condenser leg (reference view Detail B, page 3).
4. Place anchorage plate inside each condenser foot prior to fastening to the structure. Use flat washer, lock washer and nut to connect condenser to the customer supplied anchor on the solid surface (reference view Detail A, page 2). As a minimum 3/8" anchors with American National Standard series W, type A, plain washers (ANSI B18.22.1-1965, R1975) selected to match the nominal anchor diameter must be installed at each anchor location between the anchor head and equipment for load distribution.
5. See instruction included with part kit for more details.

TABLE 1

Liebert MC Model Numbers: MCS028, MCM040, MCL055
Leg height: up to 60 inches

This certification covers the following wind parameters (ultimate load):
Horizontal pressure = 107 lbs/ft²; uplift pressure = 107 lbs/ft²

**WIND LOAD DATA
TWO FAN, 18" LEG HEIGHT CONFIGURATION**

WITHOUT RECEIVER

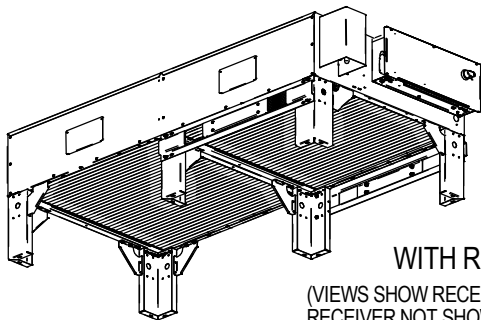
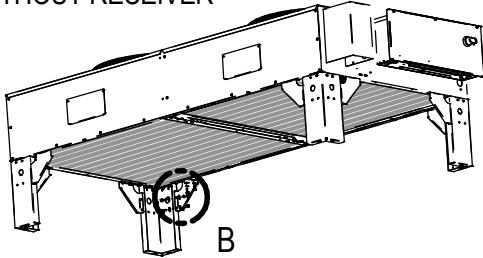

WITH RECEIVER

(VIEWS SHOW RECEIVER BRACKET ONLY.
RECEIVER NOT SHOWN FOR CLARITY)

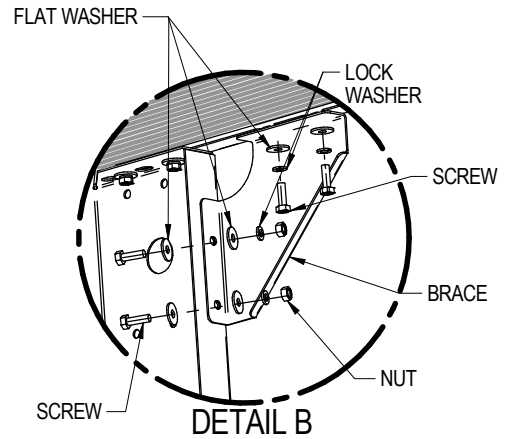

NOTES:

1. All braces and fasteners are required to maintain certification of conformity, see page 2, Detail A and page 3, Detail B.
2. Use washer, lock washer and screw to connect brace to condenser bottom beam (reference view Detail B, page 3).
3. Use washer, lock washer, screw and nut to connect brace to condenser leg (reference view Detail B, page 3).
4. Place anchorage plate inside each condenser foot prior to fastening to the structure. Use flat washer, lock washer and nut to connect condenser to the customer supplied anchor on the solid surface (reference view Detail A, page 2). As a minimum 3/8" anchors with American National Standard series W, type A, plain washers (ANSI B18.22.1-1965, R1975) selected to match the nominal anchor diameter must be installed at each anchor location between the anchor head and equipment for load distribution.
5. See instruction included with part kit for more details.

TABLE 2

Liebert MC Model Numbers: MCS056, MCM080, MCL110
Leg height: up to 60 inches

This certification covers the following wind parameters (ultimate load):
Horizontal pressure = 107 lbs/ft²; uplift pressure = 107 lbs/ft²

**WIND LOAD DATA
THREE FAN, 18" LEG HEIGHT CONFIGURATION**

WITHOUT RECEIVER

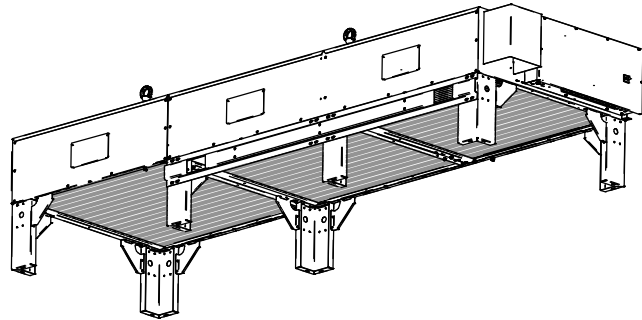
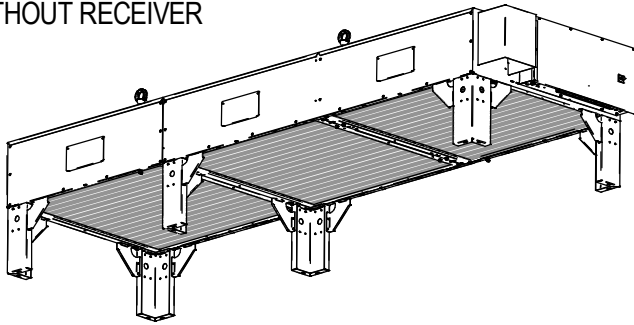

WITH RECEIVER

(VIEWS SHOW RECEIVER BRACKET ONLY.
RECEIVER NOT SHOWN FOR CLARITY)

NOTES:

1. All braces and fasteners are required to maintain certification of conformity, see page 2, Detail A and page 3, Detail B.
2. Use washer, lock washer and screw to connect brace to condenser bottom beam (reference view Detail B, page 3).
3. Use washer, lock washer, screw and nut to connect brace to condenser leg (reference view Detail B, page 3).
4. Place anchorage plate inside each condenser foot prior to fastening to the structure. Use flat washer, lock washer and nut to connect condenser to the customer supplied anchor on the solid surface (reference view Detail A, page 2). As a minimum 3/8" anchors with American National Standard series W, type A, plain washers (ANSI B18.22.1-1965, R1975) selected to match the nominal anchor diameter must be installed at each anchor location between the anchor head and equipment for load distribution.
5. See instruction included with part kit for more details.

TABLE 3

Liebert MC Model Numbers: MCL165
Leg height: up to 60 inches

This certification covers the following wind parameters (ultimate load):
Horizontal pressure = 107 lbs/ft²; uplift pressure = 107 lbs/ft²

**WIND LOAD DATA
FOUR FAN, 18" LEG HEIGHT CONFIGURATION**

WITHOUT RECEIVER

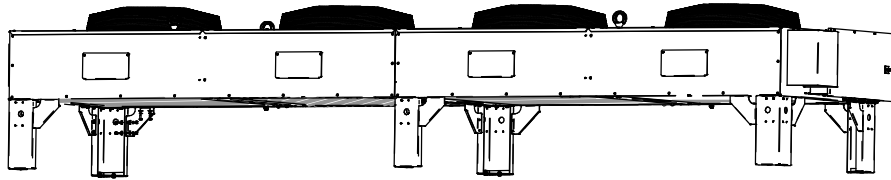

WITH RECEIVER

(VIEWS SHOW RECEIVER BRACKET ONLY.
RECEIVER NOT SHOWN FOR CLARITY)

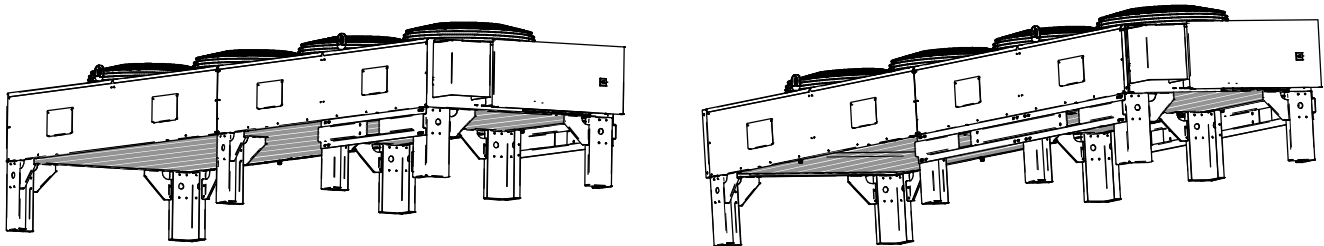

NOTES:

1. All braces and fasteners are required to maintain certification of conformity, see page 2, Detail A and page 3, Detail B.
2. Use washer, lock washer and screw to connect brace to condenser bottom beam (reference view Detail B, page 3).
3. Use washer, lock washer, screw and nut to connect brace to condenser leg (reference view Detail B, page 3).
4. Place anchorage plate inside each condenser foot prior to fastening to the structure. Use flat washer, lock washer and nut to connect condenser to the customer supplied anchor on the solid surface (reference view Detail A, page 2). As a minimum 3/8" anchors with American National Standard series W, type A, plain washers (ANSI B18.22.1-1965, R1975) selected to match the nominal anchor diameter must be installed at each anchor location between the anchor head and equipment for load distribution.
5. See instruction included with part kit for more details.

TABLE 4

Liebert MC Model Numbers: MCM160, MCL220
Leg height: up to 60 inches

This certification covers the following wind parameters (ultimate load):
Horizontal pressure = 107 lbs/ft²; uplift pressure = 107 lbs/ft²

**WIND LOAD DATA
1-4 FAN, 36-60" LEG HEIGHT CONFIGURATION**

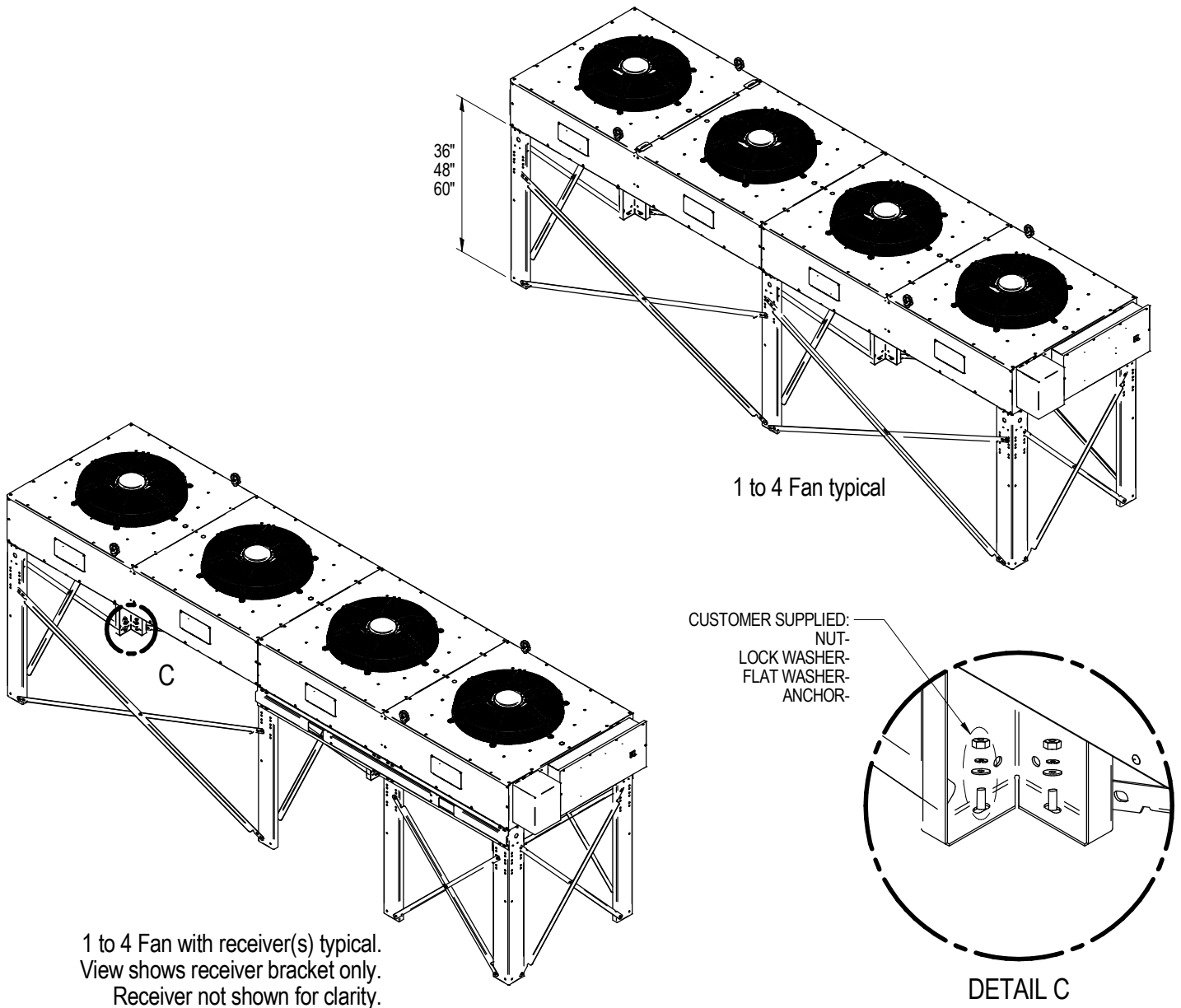

NOTES:

1. All braces and fasteners are required to maintain certification of conformity.
2. Use flat washer, lock washer and nut to connect condenser to the customer supplied anchor on the solid surface (reference view Detail C). As a minimum 3/8" anchors with American National Standard series W, type A, plain washers (ANSI B18.22.1-1965, R1975) selected to match the nominal anchor diameter must be installed at each anchor location between the anchor head and equipment for load distribution.
3. Refer to instruction provided with leg kit for more details.
4. Refer to user manual for anchor locations.

Connect with Vertiv on Social Media



<https://www.facebook.com/vertiv/>



<https://www.instagram.com/vertiv/>



<https://www.linkedin.com/company/vertiv/>



<https://www.twitter.com/Vertiv/>



Vertiv.com | Vertiv Headquarters, 505 N. Cleveland Ave., Westerville, OH 43082, USA

© 2023 Vertiv Group Corp. All rights reserved. Vertiv™ and the Vertiv logo are trademarks or registered trademarks of Vertiv Group Corp. All other names and logos referred to are trade names, trademarks or registered trademarks of their respective owners. While every precaution has been taken to ensure accuracy and completeness here, Vertiv Group Corp. assumes no responsibility, and disclaims all liability, for damages resulting from use of this information or for any errors or omissions.

SL-19536_REV16_06-23