



NetSure™ 7100 Compact DC Power System

Installation and User Manual

Specification Number: 582137100101, 582137100102, 582137100103, 582137100104, 582137100105, 582137100106

Model Number: NetSure™ 7100 Compact

The information contained in this document is subject to change without notice and may not be suitable for all applications. While every precaution has been taken to ensure the accuracy and completeness of this document, Vertiv assumes no responsibility and disclaims all liability for damages resulting from use of this information or for any errors or omissions. Refer to other local practices or building codes as applicable for the correct methods, tools, and materials to be used in performing procedures not specifically described in this document.

The products covered by this instruction manual are manufactured and/or sold by Vertiv. This document is the property of Vertiv and contains confidential and proprietary information owned by Vertiv. Any copying, use or disclosure of it without the written permission of Vertiv is strictly prohibited.

Names of companies and products are trademarks or registered trademarks of the respective companies. Any questions regarding usage of trademark names should be directed to the original manufacturer.

Technical Support Site

If you encounter any installation or operational issues with your product, check the pertinent section of this manual to see if the issue can be resolved by following outlined procedures.

Visit <https://www.vertiv.com/en-us/support/> for additional assistance.

TABLE OF CONTENTS

Admonishments Used in this Document	v
Important Safety Instructions	vi
Safety Admonishments Definitions.....	vi
Safety and Regulatory Statements.....	vi
Déclarations de Sécurité et de Réglementation.....	vi
1 Customer Documentation Package	1
2 System Description	1
3 Installation Acceptance Checklist	3
4 Installing the System	4
4.1 General Requirements.....	4
4.2 Securing the Relay Rack to the Floor (if furnished).....	5
4.3 Mounting the System in a Relay Rack or a Cabinet Equipment Rack (if required).....	8
4.4 Securing the System Horizontally to a Wall with P/N 565533 Mounting Bracket Kit (if furnished).....	9
4.5 Installing Optional Lug Adapter Busbar Kits.....	11
4.6 Installing Circuit Breakers.....	12
5 Setting Switch Options	13
5.1 Circuit Cards with Switches.....	13
5.2 Switch Settings on the IB2 (Controller Interface Board).....	14
5.3 Switch Settings on the EIB (Controller Extended Interface Board).....	15
6 Making Electrical Connections	16
6.1 Important Safety Instructions.....	16
6.2 Wiring Considerations.....	16
6.3 Relay Rack / Equipment Cabinet Frame Grounding Connection.....	17
6.4 System Shelf and Wall Mount Bracket Frame Grounding Connection.....	18
6.5 Central Office Ground Connection.....	20
6.6 Rectifier AC Input and AC Input Equipment Grounding Connections (Nominal 100 VAC / 120 VAC / 208 VAC / 240 VAC, Single Phase).....	21
6.6.1 Wiring Considerations.....	21
6.6.2 General.....	21
6.7 External Alarm, Reference, Monitoring, and Control Connections.....	23
6.7.1 External Alarm, Reference, Monitoring, and Control Connection Locations.....	23
6.7.2 IB2 (Controller Interface Board) Connections (if required).....	24
6.7.3 EIB (Controller Extended Interface Board) Connections (if required).....	29
6.7.4 Connecting a Device or System to the NCU CAN Bus (if required).....	34
6.8 NCU Controller Ethernet Connection (if required).....	35
6.9 Load Connections.....	36
6.9.1 Important Safety Instructions.....	36
6.9.2 General.....	36
6.10 External Battery Connections.....	40
6.10.1 Important Safety Instructions.....	40
6.10.2 General.....	40
7 Installing Rectifier Modules	41

8	Initially Starting, Configuring, and Checking System Operation	41
8.1	Important Safety Instructions	41
8.2	Initial Startup Preparation	41
8.3	Initially Starting the System	41
8.4	NCU Controller Initialization	41
8.5	Verifying and Setting the NCU Controller as Required for Your Application	43
8.6	Checking System Status	51
8.7	Final Steps	51
9	Operating Procedures	51
9.1	Rectifiers and Controller	51
9.2	ESTOP Function	51
9.3	Controller Battery Charge Current Limit Feature	52
9.4	Local Controls and Indicators	52
10	Maintenance	52
10.1	System Maintenance Procedures	52
10.2	Adding a Rectifier	52
11	Troubleshooting and Repair	53
11.1	Contact Information	53
11.2	Rectifiers and Controller	53
11.3	Controller Configuration	53
11.4	System Troubleshooting Information	53
11.5	Replacement Information	54
11.6	Replacement Procedures	54
11.6.1	Important Safety Instructions	54
11.6.2	Replacing a Rectifier	54
11.6.3	Replacing the NCU Controller	54
11.6.4	Replacing a Distribution Device	54
11.6.5	Circuit Card Replacement Procedures	56
11.6.6	Replacing the Distribution Panel	61
11.6.7	Replacing a Battery or Load Disconnect Contactor	64

Admonishments Used in this Document



DANGER! Warns of a hazard the reader **will** be exposed to that will **likely** result in death or serious injury if not avoided. (ANSI, OSHA)



WARNING! Warns of a potential hazard the reader **may** be exposed to that **could** result in death or serious injury if not avoided. This admonition is not used for situations that pose a risk only to equipment, software, data, or service. (ANSI)



CAUTION! Warns of a potential hazard the reader **may** be exposed to that **could** result in minor or moderate injury if not avoided. (ANSI, OSHA) This admonition is not used for situations that pose a risk only to equipment, data, or service, even if such use appears to be permitted in some of the applicable standards. (OSHA)



ALERT! Alerts the reader to an action that **must be avoided** in order to protect equipment, software, data, or service. (ISO)



ALERT! Alerts the reader to an action that **must be performed** in order to prevent equipment damage, software corruption, data loss, or service interruption. (ISO)



FIRE SAFETY! Informs the reader of fire safety information, reminders, precautions, or policies, or of the locations of fire-fighting and fire-safety equipment. (ISO)



SAFETY! Informs the reader of general safety information, reminders, precautions, or policies not related to a particular source of hazard or to fire safety. (ISO, ANSI, OSHA)

Important Safety Instructions

Safety Admonishments Definitions

Definitions of the safety admonishments used in this document are listed under “Admonishments Used in this Document” on page v.

Safety and Regulatory Statements

Refer to Section 4154 (provided with your customer documentation) for Safety and Regulatory Statements.

Déclarations de Sécurité et de Réglementation

Reportez-vous à la Section 4154 (fourni avec les documents de votre client) pour les déclarations de sécurité et de réglementation.

1 Customer Documentation Package

This document (UM582137100101) provides *Installation and User Instructions* for the Vertiv™ NetSure™ 7100 Compact DC Power System: Model 7100 Compact; Spec. No. 582137100101, 582137100102, 582137100103, 582137100104, 582137100105, and 582137100106.

The complete Customer Documentation Package consists of...

Document Number	Document Description	How Provided
UM582137100101	System Installation and User Manual	Printed Manual
UM1M830BNA	NCU Controller User Manual	Printed Manual
UM1R483500E3	Rectifier User Manual	Electronic File
SAG582137100101, SAG582137100102, SAG582137100103, SAG582137100104, SAG582137100105, SAG582137100106	System Application Guide	Go to www.vertiv.com for a pdf version of the document.

2 System Description

See Table 2.1 for descriptions of the configured systems. Refer also to the following.

Table 2.1 Configured Systems Descriptions

Spec. No.	Description	40 °C Rating			65 °C Rating		
		100 VAC	120 VAC	208 / 240 VAC	100 VAC	120 VAC	208 / 240 VAC
582137100101	-48 VDC 350 A Power System e/w (2) LVLD's and LVBD (no front door and top cover).	N/A			217 A / 10.4 kW	278 A / 13.3 kW	350 A / 16.8 kW
582137100102	-48 VDC 500 A Power System e/w (2) LVLD's and LVBD.	281 A / 13.5 kW	360 A / 17.2 kW	500 A / 24 kW	N/A		
582137100103	-48 VDC 350 A Power System e/w no LVD's (no front door and top cover).	N/A			217 A / 10.4 kW	278 A / 13.3 kW	350 A / 16.8 kW
582137100104	-48 VDC 500 A Power System e/w no LVD's.	281 A / 13.5 kW	360 A / 17.2 kW	500 A / 24 kW	N/A		
582137100105	-48 VDC 350 A Power System e/w LVBD (no front door and top cover).	N/A			217 A / 10.4 kW	278 A / 13.3 kW	350 A / 16.8 kW
582137100106	-48 VDC 500 A Power System e/w LVBD.	281 A / 13.5 kW	360 A / 17.2 kW	500 A / 24 kW	N/A		

The Vertiv™ NetSure™ 7100 Compact DC Power System is an integrated system containing -48 VDC output rectifiers, intelligent control, metering, monitoring, and distribution.

This system is designed to power a load while charging a positive grounded battery. This system is capable of operating in a batteryless installation or off battery for maintenance purposes. The system is designed for operation with the positive output grounded.

This system consists of the following components.

NCU (NetSure Control Unit) Controller

The NCU controller provides system control (including optional low voltage battery disconnect (LVBD) and optional low voltage load disconnect (LVLD) control), rectifier control (including a charge control function), metering functions, monitoring functions, local/remote alarm functions, and connections for binary inputs and programmable relay outputs via controller interface boards. The controller also supports rectifier temperature compensation if the system is equipped with a temperature probe(s). Temperature probe(s) may also be designated to monitor ambient temperature and/or battery temperature. The controller also provides data acquisition, system alarm management, and advanced battery and energy management. The controller contains a color TFT display and keypad for local access. The controller provides an Ethernet port and comes with comprehensive webpages for remote access. The controller has SNMP V3 capability for remote system management. The controller supports software upgrade via its USB port. Refer to the NCU Controller Instructions (UM1M830BNA) for more information.

Rectifiers

The system contains nine (9) rectifier mounting positions for the Spec. No. 1R483500e3 rectifier. The rectifiers provide load power, battery float current, and battery recharge current during normal operating conditions. Refer to the Rectifier Instructions (UM1R483500E3) for more information.

Distribution

The system contains a 1-row distribution panel. The distribution panel accepts bullet nose type circuit breakers.

Low Voltage Load Disconnect (LVLD) and Low Voltage Battery Disconnect (LVBD)

Spec. No 582137100101 and 582137100102 provides two (2) LVLD and one (1) LVBD.

Spec. No 582137100103 and 582137100104 provides no LVDs.

Spec. No 582137100105 and 582137100106 provides one (1) LVBD.

Figure 2.1 Overview Illustration

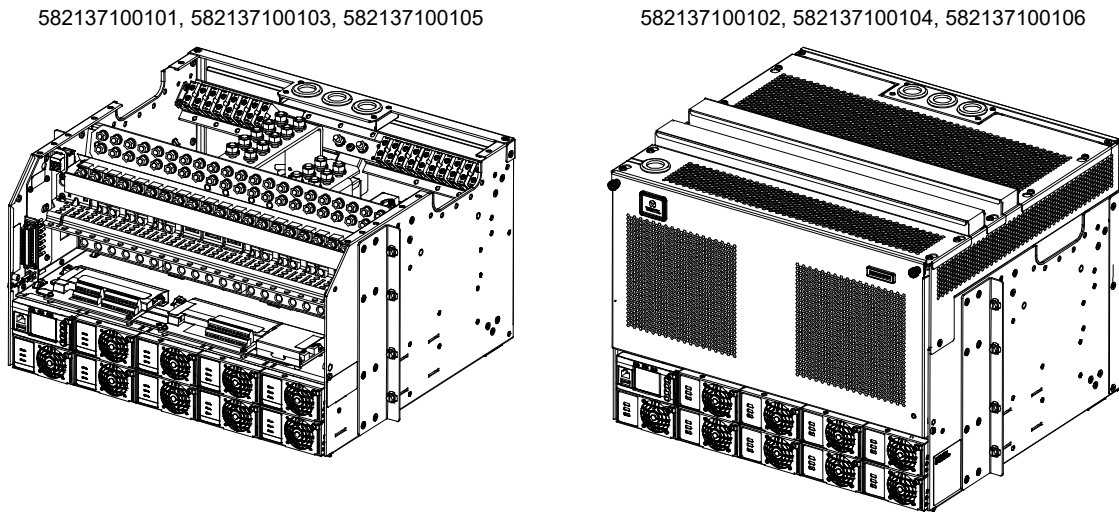

Table 2.2 Overview Table

No Covers	Covers	Low Voltage Disconnect
582137100101	582137100102	(2) LVLD, (1) LVBD
582137100103	582137100104	No LVD
582137100105	582137100106	(1) LVBD

3 Installation Acceptance Checklist

Provided in this section is an Installation Acceptance Checklist. This checklist helps ensure proper installation and initial operation of the system. As the procedures presented in this document are completed, check the appropriate box on this list. If the procedure is not required to be performed for your installation site, also check the box in this list to indicate that the procedure was read. When installation is done, ensure that each block in this list has been checked. Some of these procedures may have been factory performed for you.



NOTE! The system is not powered up until the end of this checklist.



NOTE! Some of these procedures may have been performed at the factory for you.

Installing the System

- Relay Rack Secured to Floor (if required)
- System Secured to Relay Rack or Cabinet Equipment Rack (if required)
- System Secured to Suitable Wall (if required)
- Optional Lug Adapter Busbar Kits Installed
- Circuit Breakers Installed

Setting Jumper and Switch Options

- Factory Switch Setting on IB2 (Controller Interface Board) Verified
- Factory Switch Setting on EIB (Controller Extended Interface Board) Verified

Making Electrical Connections

- Relay Rack / Cabinet Frame Grounding Connection Made
- System Shelf and Wall Mount Bracket Frame Grounding Connection Made
- Central Office Ground Connection Made
- Rectifier AC Input and AC Input Equipment Grounding Connections Made
- External Alarm, Reference, Monitoring, and Control Connections to IB2 (Controller Interface Board) Made
- External Alarm, Reference, Monitoring, and Control Connections to EIB (Controller Extended Interface Board) Made
- External Device (such as SM-Temp Module) Connection to NCU Controller CAN Bus Made (if required)
- NCU Controller Ethernet Port Connection Made
- Load Connections to Distribution Panel Made
- External Battery Connections Made

Installing the Modules

- Rectifier Modules Installed

Initially Starting the System

- System Started, Configured, and Checked

4 Installing the System

4.1 General Requirements

- The installer should be familiar with the installation requirements and techniques to be used in securing the relay rack (if furnished) to the floor.
- The installer should be familiar with the installation requirements and techniques to be used in securing the system to a relay rack or equipment rack (if required).
 - In systems with covers, the top rear cover needs to be removed to access the battery and/or CO ground connection points. If other equipment is mounted above the shelf, leave enough clearance to access the screws securing the cover.
- The installer should be familiar with the installation requirements and techniques to be used in securing the system to a suitable wall (if required).
- This product is intended only for installation in a restricted access location on or above a non-combustible surface.
- This product must be located in a controlled environment with access to crafts persons only.
- This product is intended for installation in network telecommunication facilities (CO, vault, hut, or other environmentally controlled electronic equipment enclosure).
- This product is intended for connection to the common bonding network in a network telecommunication facility (CO, vault, hut, or other environmentally controlled electronic equipment enclosure).
- The DC return connection to this system can remain isolated from system frame and chassis (DC-I).
- This system is suitable for installation as part of the Common Bonding Network (CBN).
- The system must be mounted in an environment that does not exceed the rated operating ambient temperature range found in SAG582137100101 / SAG582137100102 / SAG582137100103 / SAG582137100104 / SAG582137100105 / SAG582137100106.
- Clearance requirements are (relay rack):
 - Recommended minimum aisle space clearance for the front of each bay is 2' 6".
 - Recommended minimum aisle space clearance for the rear of each bay is 2' 0".
- Clearance requirements are (cabinet or wall mounting):
 - Recommended minimum clearance for the rear of the system is 4".

4.2 Securing the Relay Rack to the Floor (if furnished)

If the system was ordered with a relay rack or shipping rails, the system is factory mounted to the relay rack or shipping rails specified when ordered.

Secure the relay rack to the floor per site requirements. Refer also to “General Requirements” on page 4.

Ventilation Requirements

Refer to “General Requirements” on page 4.

Relay Rack Floor Mounting Dimensions

Refer to Figure 4.1 and Figure 4.2 for relay rack floor mounting dimensions.

Figure 4.1 Relay Rack Floor Mounting Dimensions - 23” (cont’d on next page)

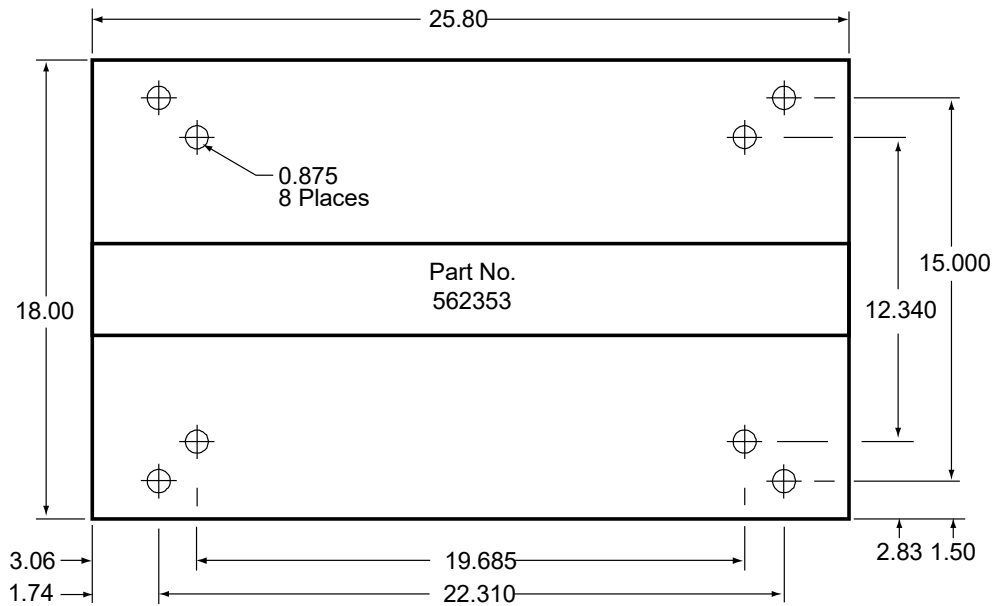

Notes:

1. All dimensions are in inches.

Figure 4.1 Relay Rack Floor Mounting Dimensions - 23" (cont'd from previous page)

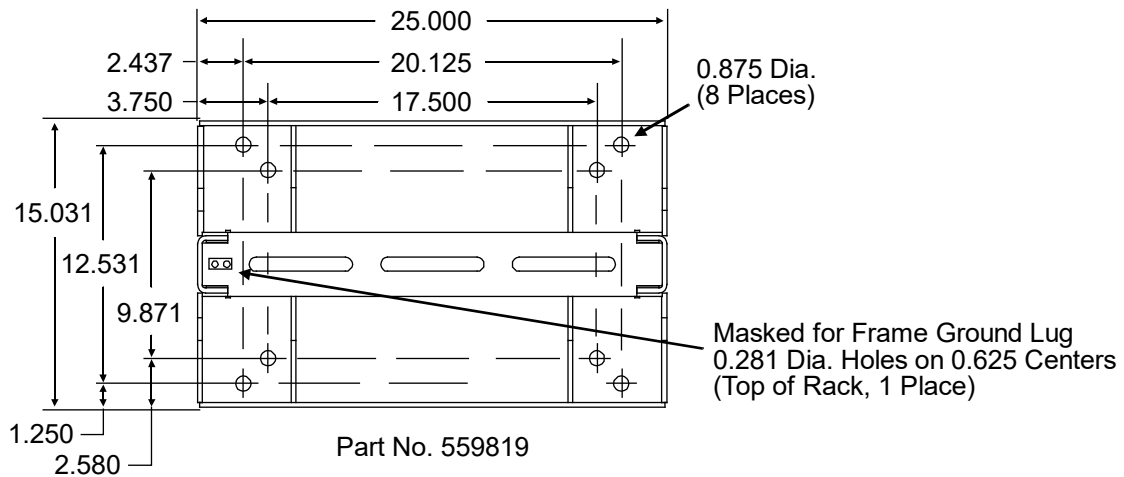
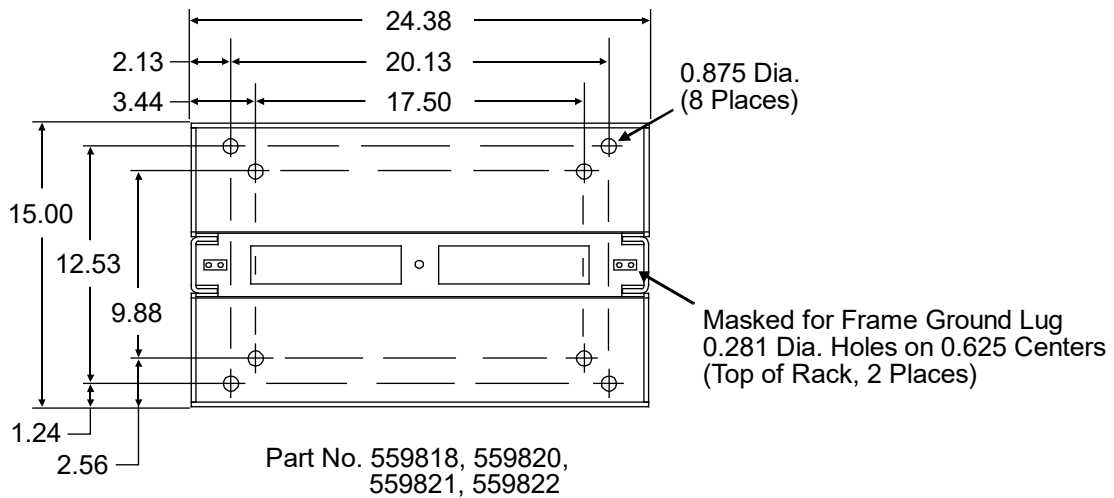
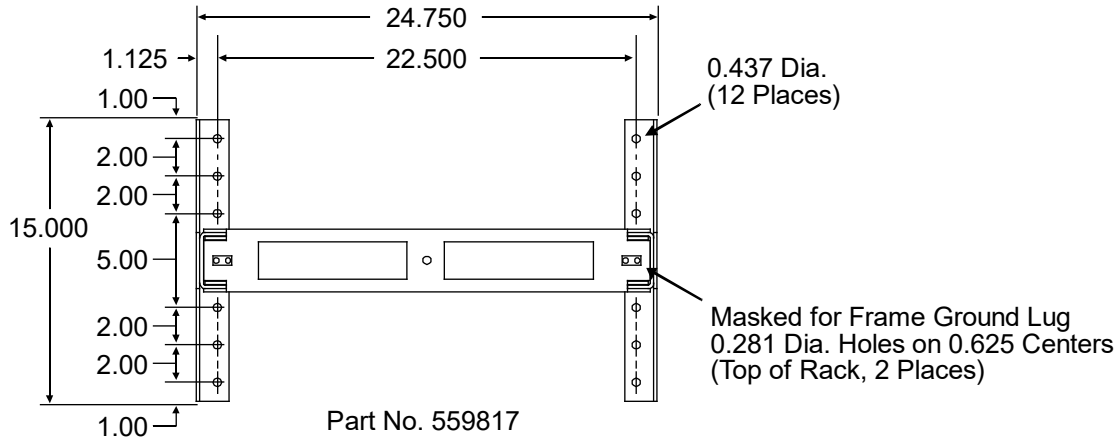

Notes:

1. All dimensions are in inches.

Figure 4.2 Relay Rack Floor Mounting Dimensions - 19"

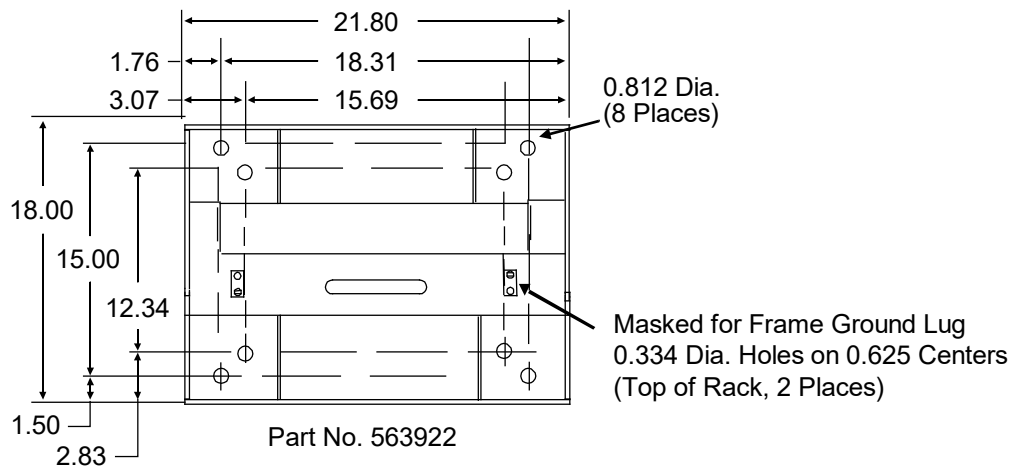
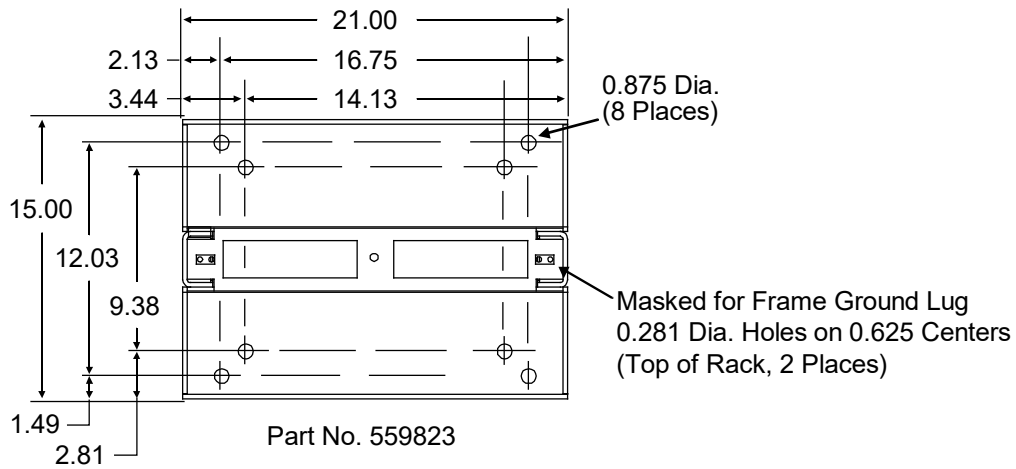
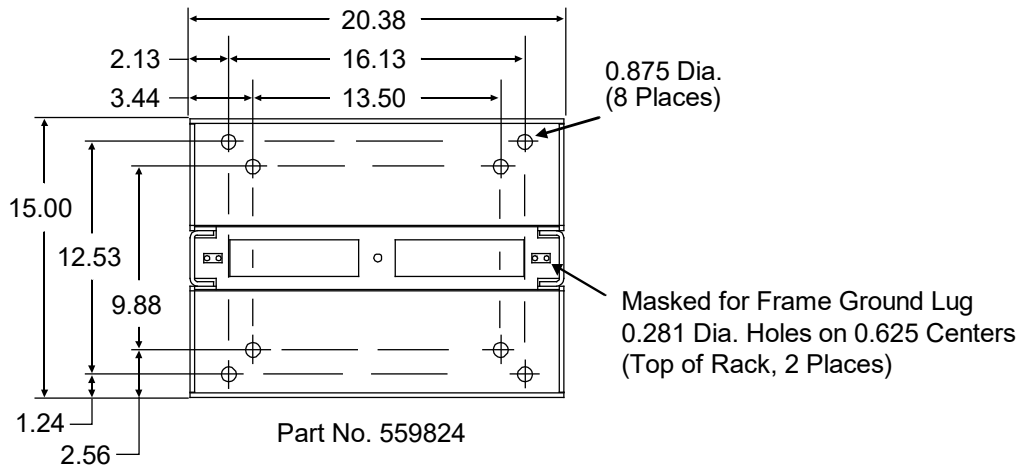

Notes:

1. All dimensions are in inches.

4.3 Mounting the System in a Relay Rack or a Cabinet Equipment Rack (if required)



DANGER! If the system is mounted in a relay rack, the relay rack must be securely anchored to the floor before the system is installed.



NOTE! If the system was ordered with a relay rack, these procedures have been performed at the factory.



NOTE! Refer to “General Requirements” on page 4 for mounting restrictions and ventilation requirements.



NOTE! A 19” to 23” wide relay rack mounting bracket adapter is available. See SAG582137100101 / SAG582137100102 / SAG582137100103 / SAG582137100104 / SAG582137100105 / SAG582137100106.

This system is designed to mount in a standard 19” or 23” relay rack or equipment rack having 1” or 1-3/4” multiple drillings (23” relay rack mounting requires separately ordered mounting bracket adapters). Refer to System Application Guide SAG582137100101 / SAG582137100102 / SAG582137100103 / SAG582137100104 / SAG582137100105 / SAG582137100106 for overall dimensions and a list of available relay racks.

The system cabinet must be the top-most component in the rack. Perform the following steps to mount the system cabinet into a relay rack or equipment rack.

Procedure

1. Position the system in the relay rack or equipment rack.
2. Secure the system to the relay rack or equipment rack using hardware as shown in Figure 4.3 (see Figure 4.3 for recommended torque). Use grounding washers as indicated in Figure 4.3.



NOTE! Install (orient) the ground washers so the teeth dig into the mounting angles for a secure ground connection.



NOTE! Compliance with Telcordia GR-1089-CORE requires that prior to mounting the system to the equipment rack:

- All paint must be removed from the front surface of each equipment rack rail where it mates with a shelf-mounting bracket, so that good metal-to-metal contact can be established between the shelf and rack.
- The shelf-to-rack mating surfaces must be cleaned.
- Electrical anti-oxidizing compound must be applied to the shelf-to-rack mating surfaces.

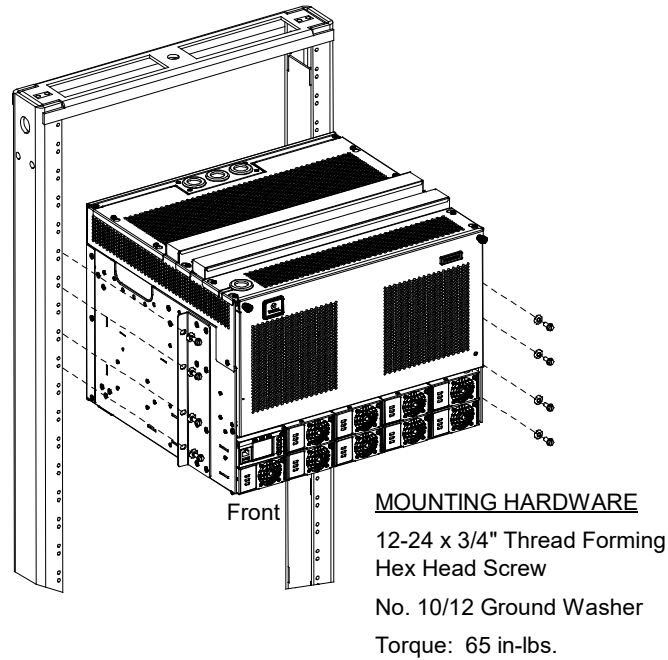
Figure 4.3 Mounting the System in a Relay Rack or a Cabinet Equipment Rack

4.4 Securing the System Horizontally to a Wall with P/N 565533 Mounting Bracket Kit (if furnished)

An optional wall mount bracket kit (P/N 565533) is available for mounting the system horizontally on a wall.



NOTE! Refer to "General Requirements" on page 4 for mounting restrictions and ventilation requirements.



NOTE! Refer to Figure 4.4 when performing this procedure.

Procedure

1. The installer must provide fasteners for securing the system to a wall or other horizontal surface. Ensure that the wall and fastening technique are suitable for supporting the weight of the system. Refer to System Application Guide SAG582137100101 / SAG582137100102 / SAG582137100103 / SAG582137100104 / SAG582137100105 / SAG582137100106 for system weight and additional dimensions.
2. Prepare the wall for customer-furnished fasteners. Secure the wall bracket to the wall.
3. Attach the system to the wall bracket using the standard mounting technique. See "Mounting the System in a Relay Rack or a Cabinet Equipment Rack (if required)" on page 8.

Figure 4.4 Mounting the System Horizontally on a Wall with Mounting Bracket Kit P/N 565533

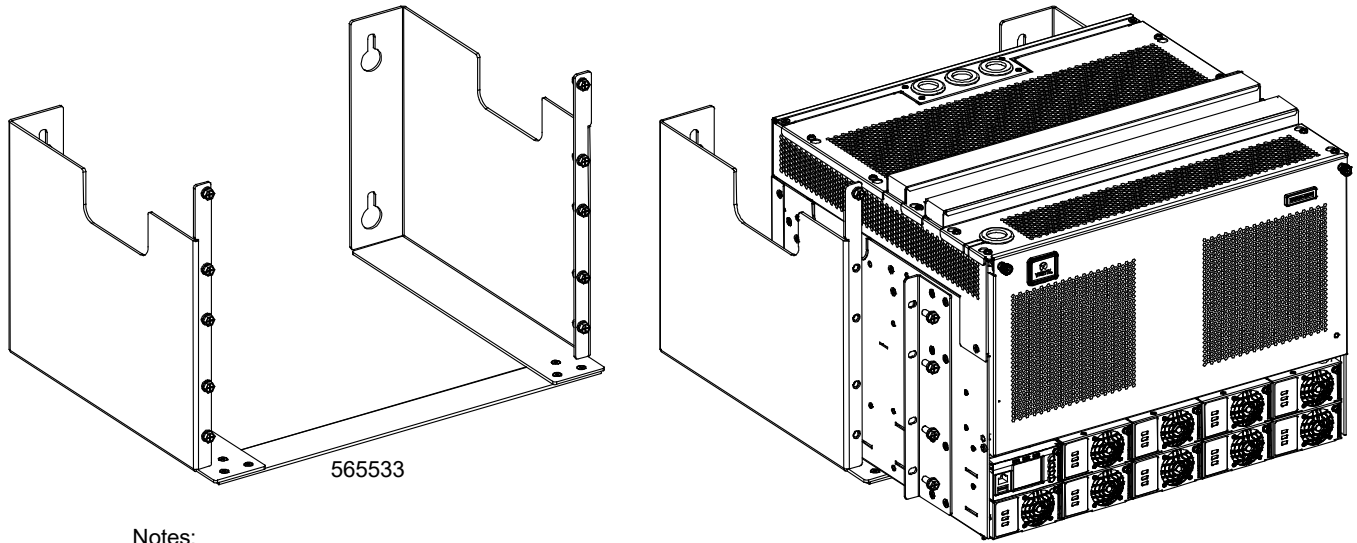

Notes:

1. All dimensions are in inches, unless otherwise specified.
2. Installer to furnish hardware for fastening bracket to wall.

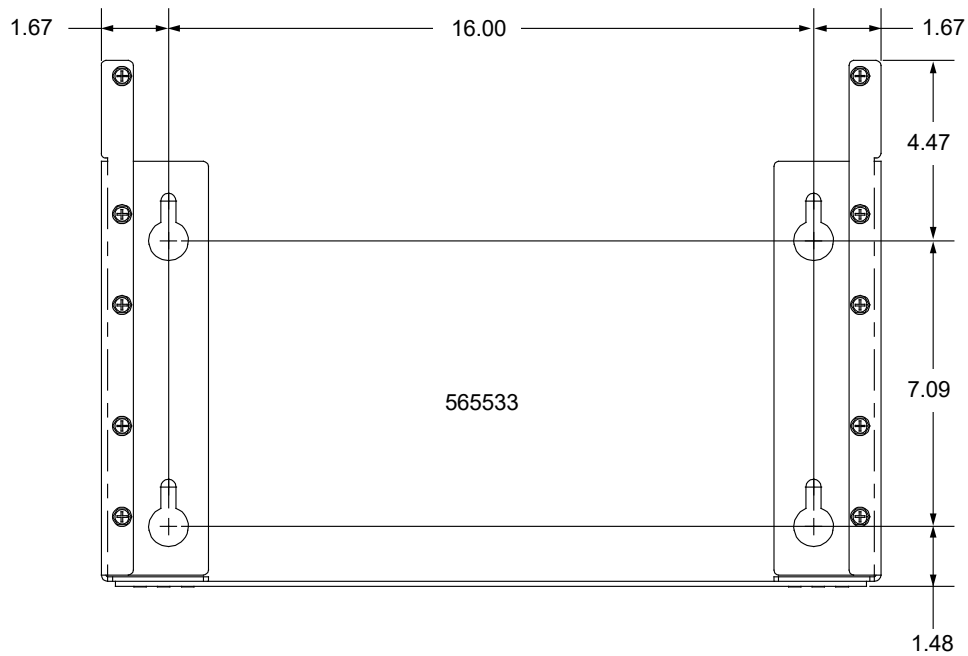

4.5 Installing Optional Lug Adapter Busbar Kits

These kits provide lug adapter busbars plus hardware for use with 2-pole and 3-pole circuit breakers. A right angle kit is also available for 1-pole devices.

Procedure

1. Refer to Figure 4.5 to install the lug adapter busbars kits.

Figure 4.5 Installing Optional Lug Adapter Busbar Kits

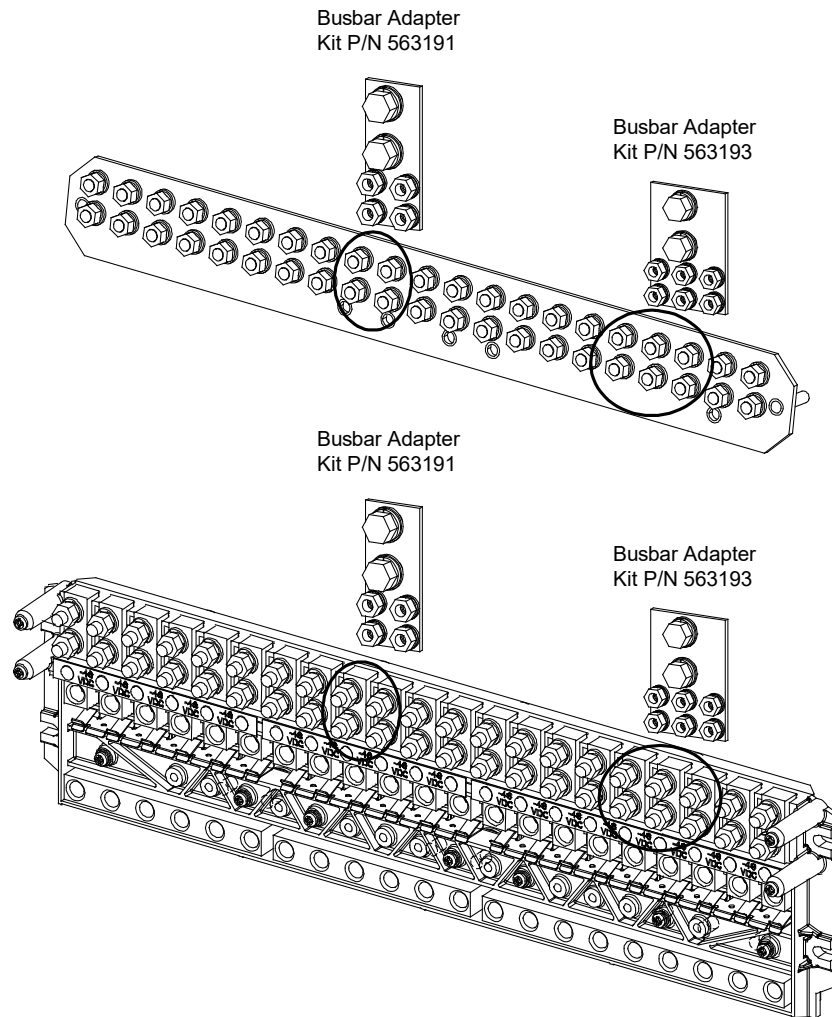

Apply anti-oxidizing compound to busbar mating surfaces before assembling.

Recommended torque is 45 in-lbs using the supplied M6 hardware.

1/4" hardware included with lug adapters can be discarded.

4.6 Installing Circuit Breakers

Circuit breakers may have been factory installed for you. If so, verify their positions and sizes.

Installing Bullet Nose Type Circuit Breakers



CAUTION! See SAG582137100101 / SAG582137100102 / SAG582137100103 / SAG582137100104 / SAG582137100105 / SAG582137100106 for temperature, sizing, and spacing restrictions.

Refer to the following procedure and install appropriately sized bullet nose type circuit breakers as required.

Procedure



NOTE! Refer to Figure 4.6 as this procedure is performed.

1. Ensure that the circuit breaker is in the OFF position and is of the correct rating. Orient the circuit breaker as shown in Figure 4.6. Insert the terminals on the rear of the circuit breaker into their corresponding sockets on the distribution panel. Ensure the alarm contact on the back of the circuit breaker makes contact with the alarm terminal on the spring strip. Push distribution device in firmly until fully seated in the distribution panel.
2. Record all circuit breaker sizes on the label provided on the shield.

Figure 4.6 Installing a Bullet Nose Type Circuit Breaker

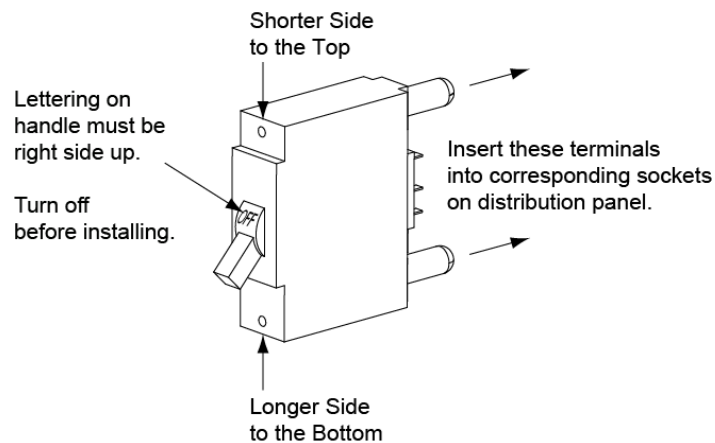

5 Setting Switch Options

5.1 Circuit Cards with Switches

Refer to Figure 5.1.

Figure 5.1 Circuit Cards with Switches

582137100101 Shown, others similar

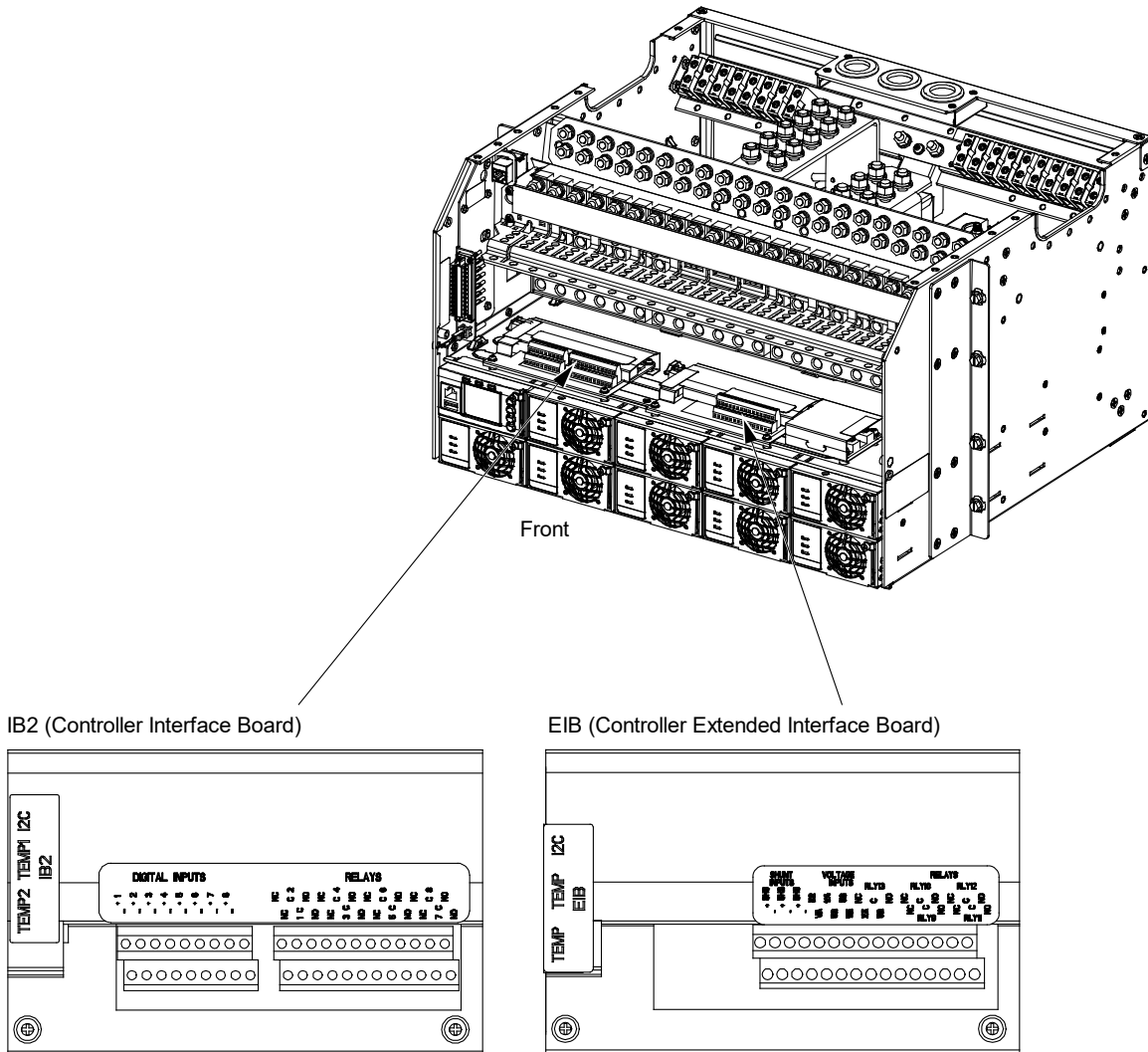

5.2 Switch Settings on the IB2 (Controller Interface Board)

NOTE! Switch setting verification is only necessary for systems that have more than one IB2 (Controller Interface Board) installed. For this system the following is the suggested setting (this is the factory default setting).

Dip Switch SW1 on the IB2 board is used to set the communications address for this board. Refer to Table 5.1 for SW1 settings. Refer to Figure 5.1 for circuit card location. Refer to Figure 5.2 for SW1 location.

Perform the following procedure to verify the factory settings.

This procedure can also be used to make adjustments on a replacement circuit card.

Procedure

1. Ensure SW1 is set per Table 5.1. Refer to Figure 5.2 for location.

Table 5.1 IB2 Interface Board Switch Settings

Setting	DIP Switch SW1	
	1	2
IB2	OFF	OFF

Figure 5.2 IB2 Interface Board Switch Location and Settings

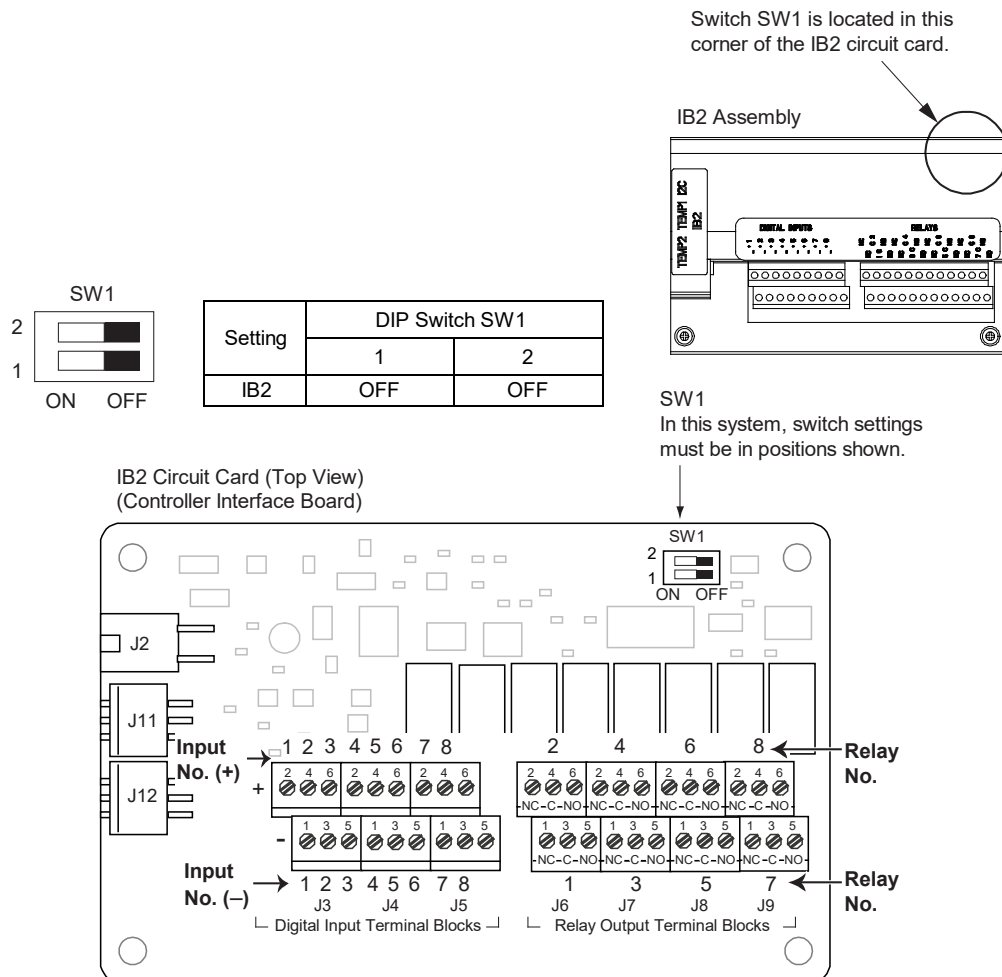

5.3 Switch Settings on the EIB (Controller Extended Interface Board)

NOTE! Switch setting verification is only necessary for systems that have more than one EIB (Controller Extended Interface Board) installed. For this system the following is the suggested setting (this is the factory default setting).

Dip Switch SW1 on the EIB board is used to set the communications address for this board. Refer to Table 5.2 for SW1 settings. Refer to Figure 5.1 for circuit card location. Refer to Figure 5.3 for SW1 location.

Perform the following procedure to verify the factory settings.

This procedure can also be used to make adjustments on a replacement circuit card.

Procedure

1. Ensure SW1 is set per Table 5.2. Refer to Figure 5.3 for location.

Table 5.2 EIB Extended Interface Board Switch Settings

Setting	DIP Switch SW1	
	1	2
EIB	OFF	OFF

Figure 5.3 EIB Extended Interface Board Switch Location and Settings

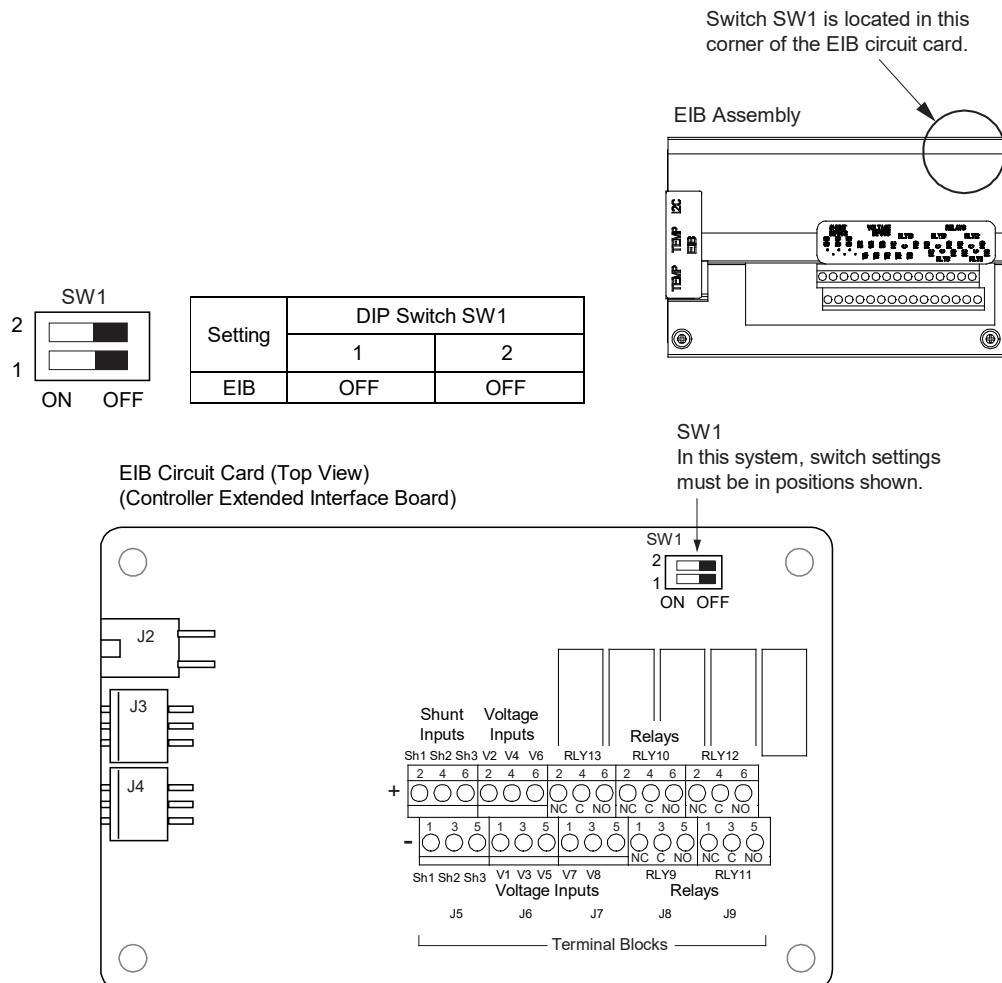

6 Making Electrical Connections

6.1 Important Safety Instructions



DANGER! Adhere to the “Important Safety Instructions” starting on page vi.

6.2 Wiring Considerations

All wiring and branch circuit protection should follow the current edition of the American National Standards Institute (ANSI) approved National Fire Protection Association's (NFPA) National Electrical Code (NEC), and applicable local codes. For operation in countries where the NEC is not recognized, follow applicable codes.

For wire size, branch circuit protection, crimp lug, and general wiring recommendations; refer to System Application Guide SAG582137100101 / SAG582137100102 / SAG582137100103 / SAG582137100104 / SAG582137100105 / SAG582137100106.

Lugs should be crimped per lug manufacturer's specifications.

Refer to Table 6.1 for supplemental lug crimping information when using the special application crimp lug / strap combination.

Table 6.1 Supplemental Lug Crimping Information when Using the Special Application Crimp Lug / Strap Combination

Crimp Lug Part No.		Crimp Tool Required ¹ , T&B Model TBM12 or TBM15 Hydraulic Heads		
		Color Key	Die Index/ Code No.	Die Cat. Number
245393500	Burndy: YA25L-4TCG1	Pink	42H	15508
245393600	Burndy: YA26L-4TCG1	Black	45	15526
245393700	Burndy: YA27L-4TCG1	Orange	50	15530
245393800	Burndy: YA28L-4TCG1	Purple	54H	15511
514872	T & B: 256-30695-1879	Yellow	62	15510
	Burndy: YA29L-4TCG1			
514873	T & B: 256-30695-1880	Red	71	15514
	Burndy: YA31L-4TCG1			

¹ The lugs should be crimped to the specifications given in the manufacturer's instructions furnished with the crimp tool or lug.

6.3 Relay Rack / Equipment Cabinet Frame Grounding Connection

For relay rack / equipment cabinet grounding requirements, refer to the current edition of the American National Standards Institute (ANSI) approved National Fire Protection Association's (NFPA) National Electrical Code (NEC), applicable local codes, and your specific site requirements.

Attach a customer grounding network lead to the equipment mounting rack per site requirements. Holes are provided on the top of each relay rack for installing a lead with a two-hole lug that has 1/4" bolt clearance holes on 5/8" centers. When using 1/4-inch hardware, recommended torque is 84 in-lbs. when a standard flat washer and lock washer are used. Refer to Figure 6.1 for locations.



NOTE! REMOVE TAPE FROM HOLE LOCATIONS BEFORE INSTALLING LUG.



NOTE! The DC return connection to this system can remain isolated from system frame and chassis (DC-I).



NOTE! This system is suitable for installation as part of the Common Bonding Network (CBN).

Figure 6.1 Relay Rack Frame Grounding Connection Points

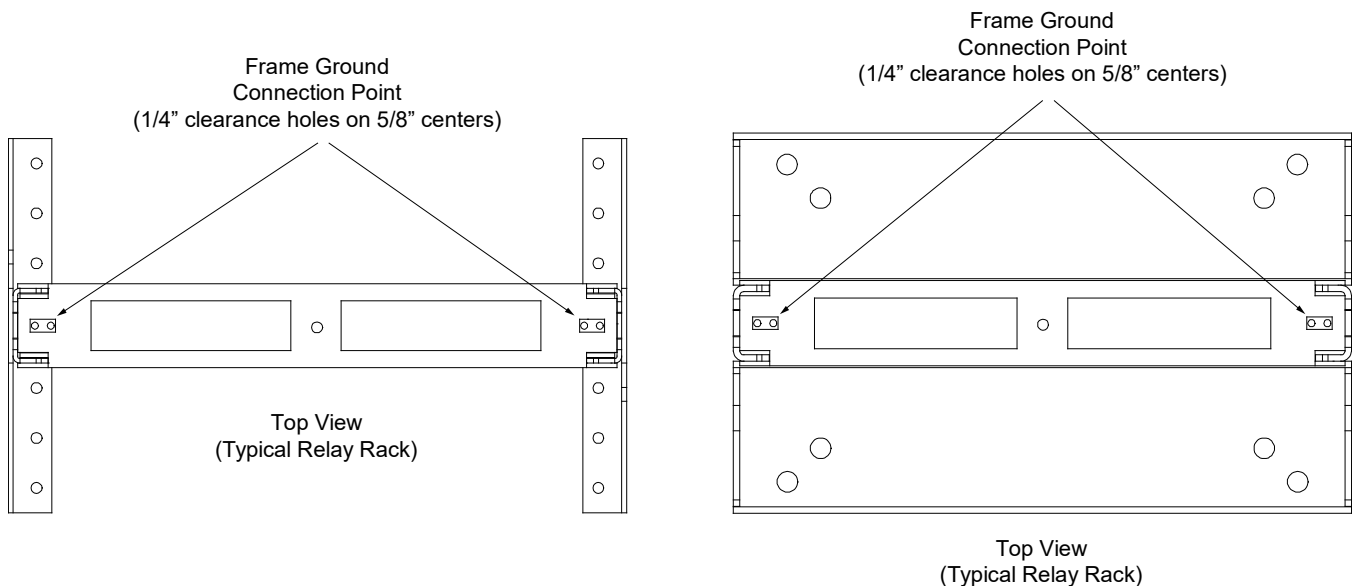

6.4 System Shelf and Wall Mount Bracket Frame Grounding Connection

For system shelf and wall mount bracket frame grounding requirements, refer to the current edition of the American National Standards Institute (ANSI) approved National Fire Protection Association's (NFPA) National Electrical Code (NEC), applicable local codes, and your specific site requirements.



NOTE! The DC return connection to this system can remain isolated from system frame and chassis (DC-I).



NOTE! This system is suitable for installation as part of the Common Bonding Network (CBN).

Procedure

1. The frame grounding connection to the shelf is made by using grounding washers with the mounting hardware used to secure the shelf to the relay rack or equipment cabinet. Refer to "Mounting the System in a Relay Rack or a Cabinet Equipment Rack (if required)" on page 8. Ensure that the relay rack or equipment cabinet is properly grounded.



NOTE! A frame ground stud is located inside the system shelf. Provide a grounding lead, if required. Refer to Figure 6.2 and Figure 6.3 for location.

Figure 6.2 System Shelf and Wall Mount Bracket Frame Grounding Connection Point (582137100101, 582137100103, 582137100105)

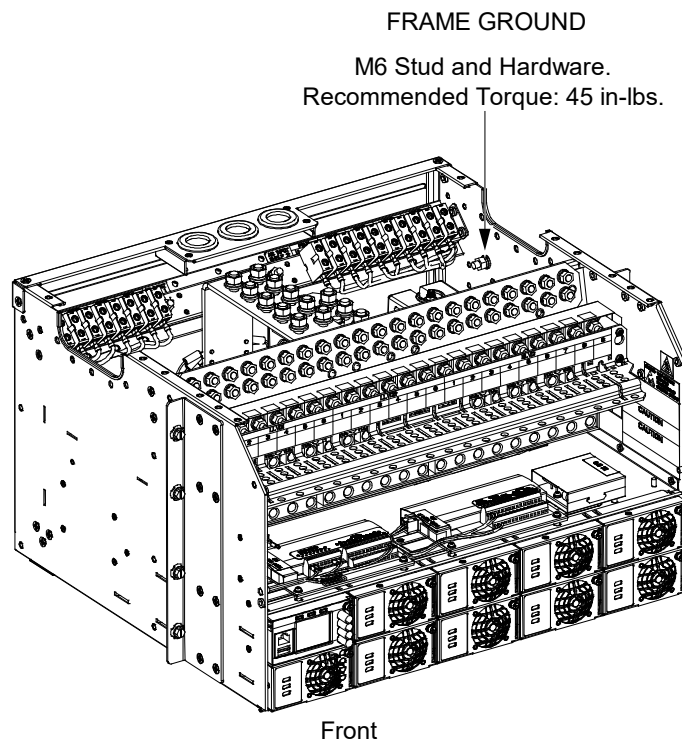
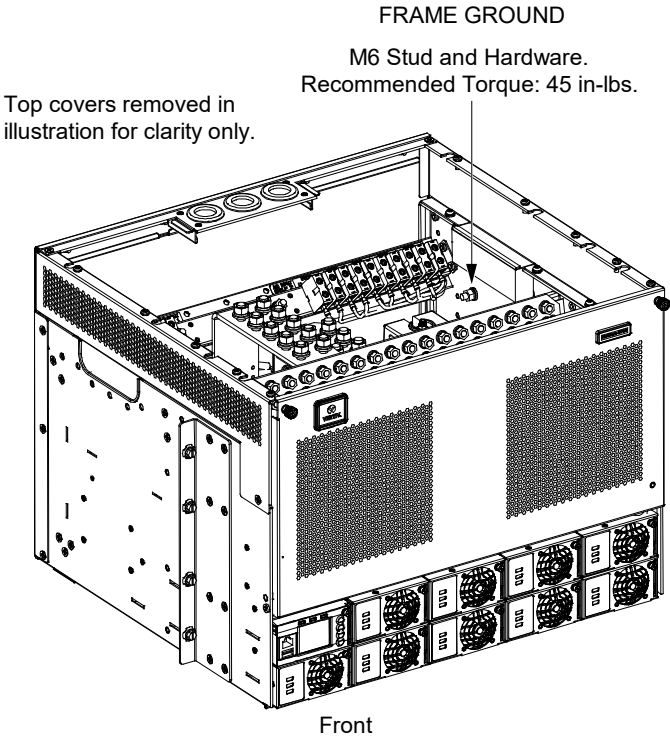

Figure 6.3 System Shelf and Wall Mount Bracket Frame Grounding Connection Point (582137100102, 582137100104, 582137100106)



6.5 Central Office Ground Connection

Landing points are provided on the battery return bus for a central office ground lead (see Figure 6.4). For central office grounding requirements, refer to the current edition of the American National Standards Institute (ANSI) approved National Fire Protection Association's (NFPA) National Electrical Code (NEC), applicable local codes, and your specific site requirements.

Figure 6.4 Central Office Ground Connection

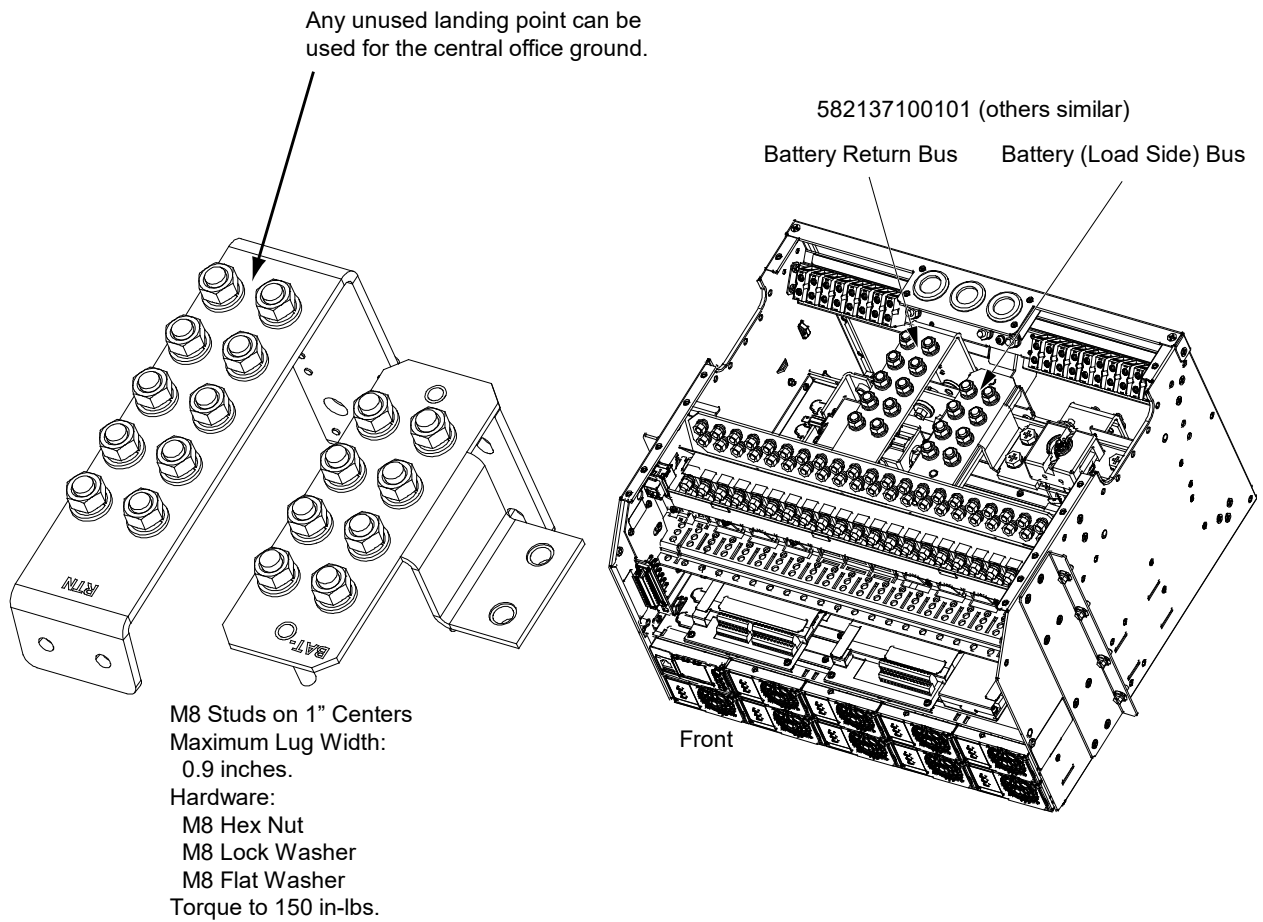

6.6 Rectifier AC Input and AC Input Equipment Grounding Connections (Nominal 100 VAC / 120 VAC / 208 VAC / 240 VAC, Single Phase)



DANGER! Adhere to the “Important Safety Instructions” starting on page vi.

6.6.1 Wiring Considerations

For wire size, branch circuit protection, crimp lug, and general wiring recommendations; refer to System Application Guide SAG582137100101 / SAG582137100102 / SAG582137100103 / SAG582137100104 / SAG582137100105 / SAG582137100106.

6.6.2 General

The system cabinet provides circular openings on the top rear of the cabinet for rectifier AC input and grounding conductors. The openings accept 3/4-inch conduit fittings. It is recommended that AC input wiring be provided to all rectifier mounting positions, including currently unused positions. This wiring will ease future installation of rectifiers to meet increased load requirements.



NOTE! A grounding conductor must be provided with each conduit.

Refer to Figure 6.5 for connection details and recommended torque.

Procedure

1. For systems with covers, remove the top rear cover from the system cabinet.
2. Install conduit fittings as required in the openings in the top rear of the system cabinet. Plug buttons are provided, and must be installed in the openings not being used.
3. Route wiring into the system cabinet through the previously installed conduit fittings.
4. Make input connections as shown in Figure 6.5. Connect each wire by inserting the stripped end into the wire opening, and then tightening the screw. Torque connections to value shown in the appropriate illustration.



NOTE! The wires must be fully inserted into the power terminal, ensuring that no uninsulated part of the wire is exposed to the end user.



NOTE! Make equipment grounding connections to earth ground, *not* to the branch circuit neutral conductor.

5. Connect equipment grounding leads to the frame ground studs using installer-provided ring lugs and factory-supplied mounting hardware. Torque connections to value shown in the appropriate illustration.
6. After all input and equipment grounding connections have been made and checked, reinstall the top rear cover, if required.

Figure 6.5 Rectifier AC Input and AC Input Equipment Grounding Connections
(Nominal 100 VAC / 120 VAC / 208 VAC / 240 VAC, Single Phase)

RECTIFIER AC INPUT
1 FEED PER 1 RECTIFIER
100 VAC / 120 VAC / 208 VAC / 240 VAC
50 Hz / 60 Hz, SINGLE PHASE

PCU1		PCU2		PCU3		PCU4		AC INPUT SHELF 1		AC INPUT SHELF 2		PCU5		PCU6		PCU7		PCU8		PCU9	
L1	L2/N	L1	L2/N	L1	L2/N	L1	L2/N	L1	L2/N	L1	L2/N	L1	L2/N	L1	L2/N	L1	L2/N	L1	L2/N	L1	L2/N

RECTIFIER MODULE
AC INPUT SHELF 1

FRAME GROUND

RECTIFIER MODULE
AC INPUT SHELF 1

Wire Size Capacity:
20 AWG to 6 AWG.
Recommended Torque:
20 in-lbs.

Three (3) M6 x 15 mm Studs and Hardware.
Recommended Torque: 45 in-lbs.

Wire Size Capacity:
20 AWG to 6 AWG.
Recommended Torque:
20 in-lbs.

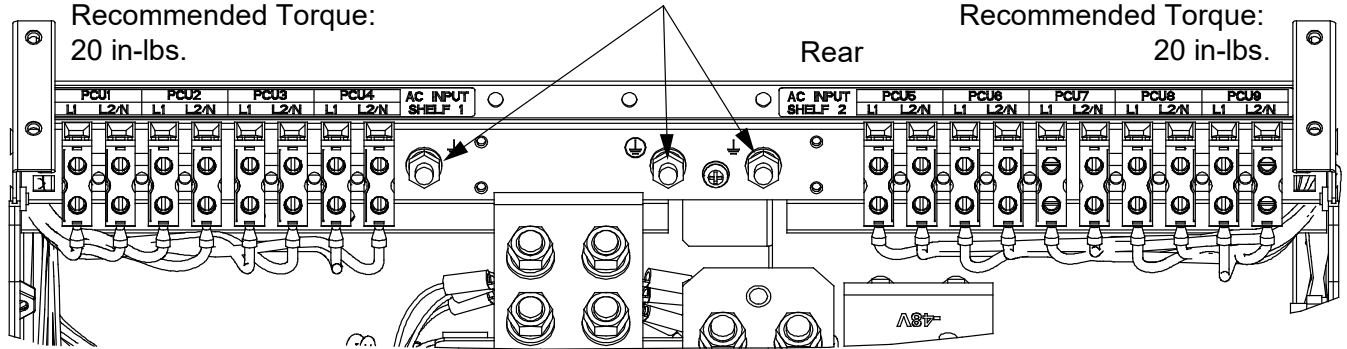

Top View
Three (3) 1.10" conduit knockouts
provided for nominal 3/4" conduit.

Line to Line:
Connect Line 1 to L1.
Connect Line 2 to L2.

Line to Neutral
Connect Line to L1.
Connect Neutral to N.

Covers (if furnished)
not shown.

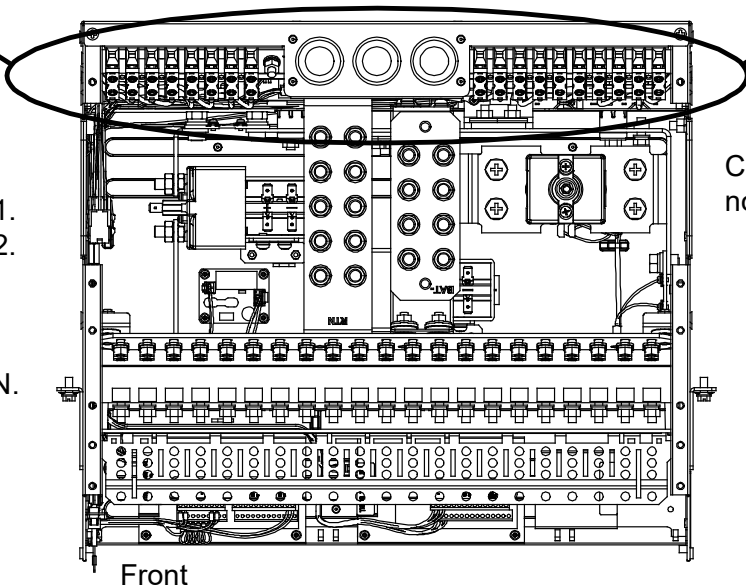

Rectifier modules are numbered left
to right as viewed from the front.

6.7 External Alarm, Reference, Monitoring, and Control Connections

6.7.1 External Alarm, Reference, Monitoring, and Control Connection Locations

Refer to Figure 6.6.

Figure 6.6 External Alarm, Reference, Monitoring, and Control Connections Locations

582137100101 Shown, others similar

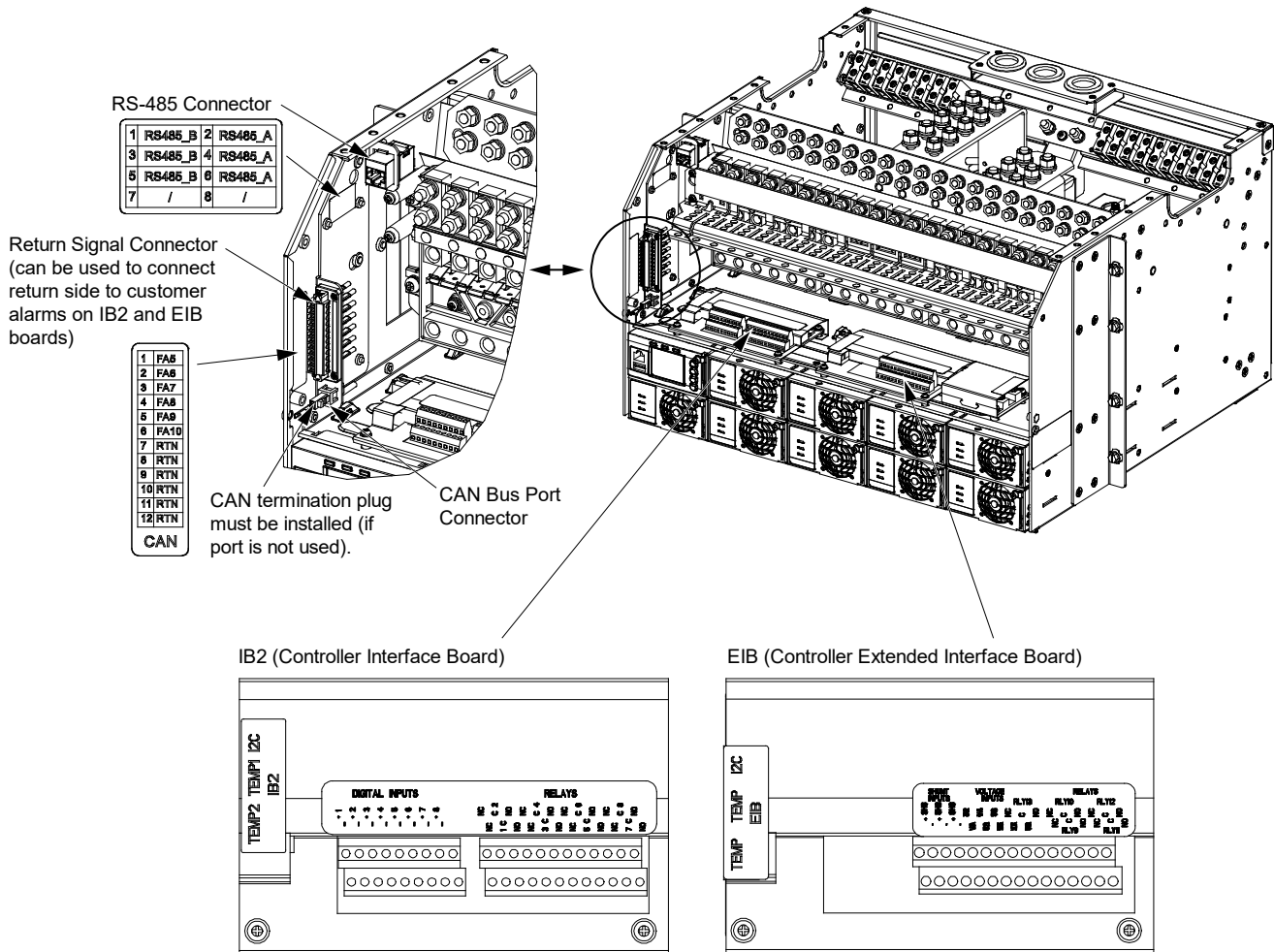

6.7.2 IB2 (Controller Interface Board) Connections (if required)

The IB2 (Controller Interface Board) provides connection points for digital inputs, programmable relay outputs, and temperature probes. The IB2 interface board is mounted inside the system cabinet. Refer to Figure 6.6.

Digital Inputs and Programmable Relay Outputs

Digital input and relay output leads are connected to screw-type terminal blocks located on the IB2. Recommended torque for these connections is 2.2 in-lbs. Refer to Figure 6.7 for terminal locations. Refer to Table 6.2 and Table 6.3 for pin-out information.

Digital Inputs

Connect up to eight (8) digital inputs to the IB2. Note that you must supply both paths for the digital input (either a positive or negative signal and the opposite polarity return path). Observe proper polarity. Refer to Figure 6.7 for terminal locations and Table 6.2 for pin-out information.

The digital inputs can be programmed to provide an alarm when the signal is applied (HIGH) or removed (LOW). Refer to the NCU Instructions (UM1M830BNA) for programming information.

Digital Input Ratings: Refer to the following.

- a) Maximum Voltage Rating: 60V DC.
- b) Active High: > 19V DC.
- c) Active Low: < 1V DC.

The digital inputs may be preprogrammed for specific functions. Refer to the configuration drawing (C-drawing) supplied with your system for your system's specific configuration.

Programmable Relay Outputs

The IB2 provides eight (8) programmable alarm relays with dry Form-C contacts. Connect up to eight (8) relay outputs to the IB2. Refer to Figure 6.7 for terminal locations and Table 6.3 for pin-out information.

Refer to the NCU Instructions (UM1M830BNA) for programming information.

Relay Ratings: Refer to the following.

- a) Steady State: 0.5 A @ 60 VDC, 1.0 A @ 30 VDC.
- b) Peak: 3 A @ 30 VDC.

The relays may be preprogrammed for specific functions. Refer to the configuration drawing (C-drawing) supplied with your system for your system's specific configuration.

Temperature Probes



NOTE! Each temperature probe consists of two or three pieces that plug together to make a complete probe. See SAG582137100101 / SAG582137100102 / SAG582137100103 / SAG582137100104 / SAG582137100105 / SAG582137100106 for part numbers and descriptions.

Temperature probes are connected to the IB2 (Controller Interface Board) and/or optional EIB (Controller Extended Interface Board) mounted inside the distribution cabinet.

Up to two (2) temperature probes can be connected to the IB2. Up to two (2) additional temperature probes can be connected to the EIB. Any combination of the four (4) temperature probes can be programmed to monitor ambient temperature and/or battery temperature. A temperature probe set to monitor battery temperature can also be used for the rectifier battery charge temperature compensation feature, or the battery charge temperature compensation feature can be programmed to use the average or highest

value of all battery temperature probes. The battery charge temperature compensation feature allows the controller to automatically increase or decrease the output voltage of the system to maintain battery float current as battery temperature decreases or increases, respectively. Battery life can be extended when an optimum charge voltage to the battery with respect to temperature is maintained. A temperature probe set to monitor battery temperature can also be used for the BTRM (Battery Thermal Runaway Management) feature. The BTRM feature lowers output voltage when a high temperature condition exists to control against battery thermal runaway.

The temperature sensor end of the probe contains a tab with a 5/16" clearance hole for mounting.

A temperature probe programmed to monitor battery temperature should be mounted on the negative post of a battery cell to sense battery temperature. A temperature probe used for battery charge temperature compensation and/or BTRM (Battery Thermal Runaway Management) should also be mounted on the negative post of a battery cell. A temperature probe programmed to monitor ambient temperature should be mounted in a convenient location, away from direct sources of heat or cold.

Figure 6.7 IB2 (Controller Interface Board) Connections

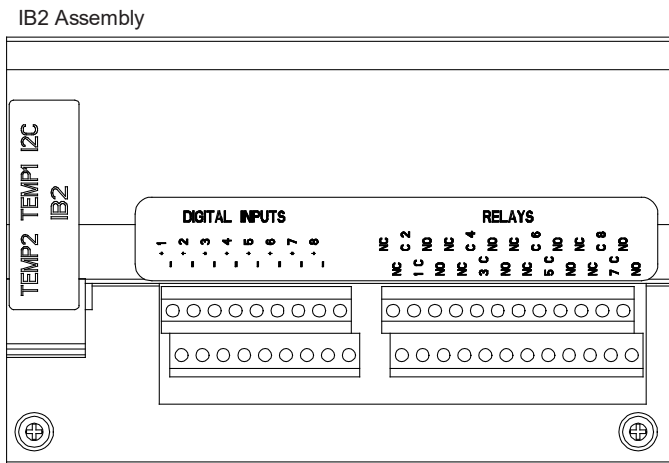
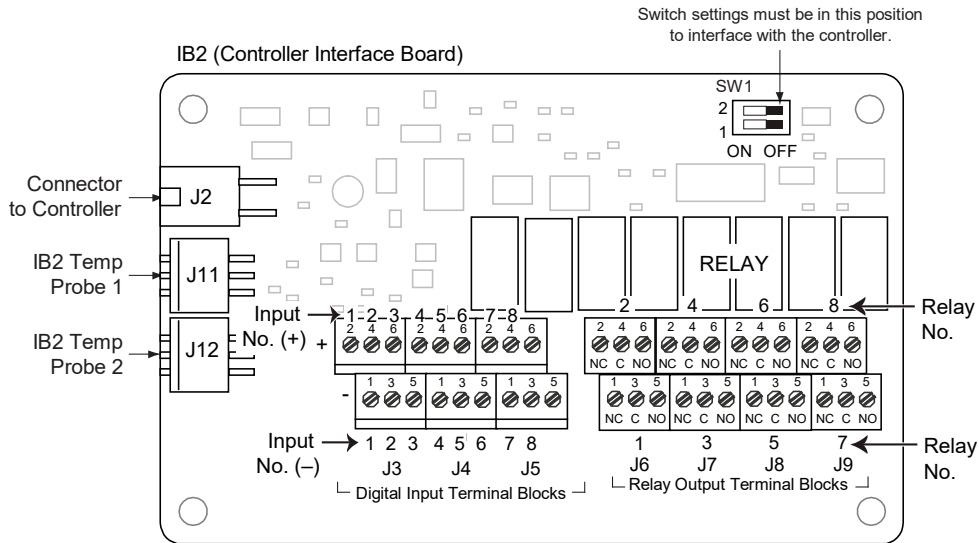
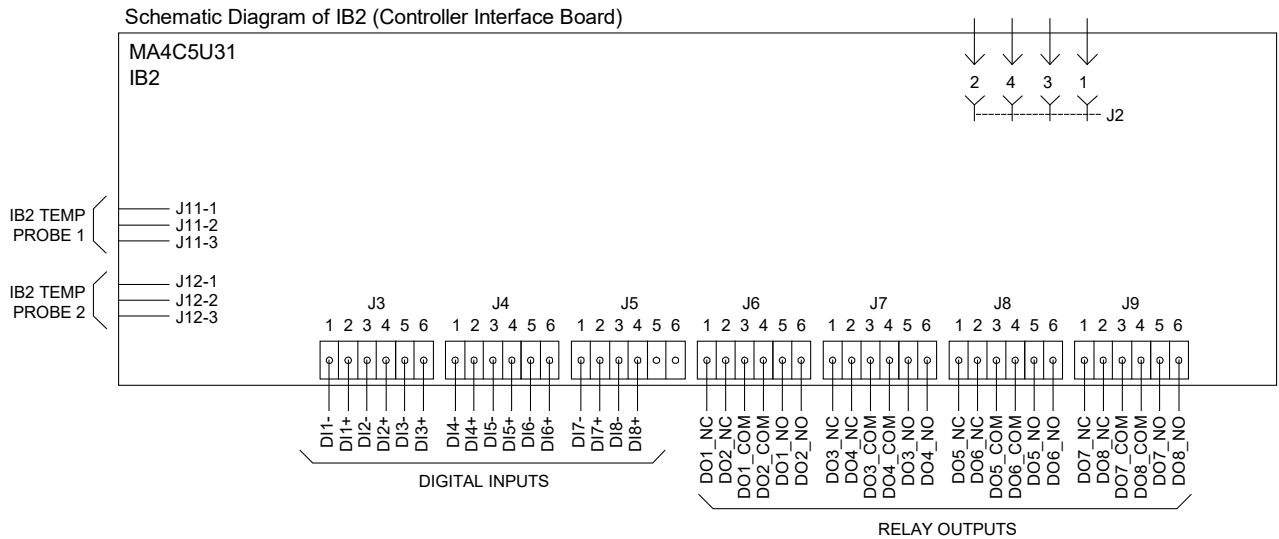

The controller relay assigned to “Critical Summary” alarm (IB2 relay 1 by default) will operate in the “Fail Safe Mode”. “Fail Safe Mode” means Relay 1 is de-energized during an alarm condition, opening the contacts between the C and NO terminals, and closing the contacts between the C and NC terminals.

The remaining IB2 relays energize during an alarm condition, closing the contacts between the C and NO terminals, and opening the contacts between the C and NC terminals.

Refer to the configuration drawing (C-drawing) supplied with your system for your system’s specific relay labeling.

Not all I/O points are available for customer connection (some are used for factory system connections).

J3-J9:

Wire Size Capacity: 16 AWG to 26 AWG.

Wire Strip Length: 0.20 inch.

Recommended Torque: 2.2 in-lbs.

Table 6.2 Programmable Digital Inputs (Factory Default) – IB2

Programmable Digital Input	IB2 Pin No.		Function	
IB2-1 DI1	J3-2	+	The digital inputs may be preprogrammed for specific functions and have factory wiring connected. Refer to the configuration drawing (C-drawing) supplied with your system for your system's specific configuration.	
	J3-1	-		
IB2-1 DI2	J3-4	+		
	J3-3	-		
IB2-1 DI3	J3-6	+		
	J3-5	-		
IB2-1 DI4	J4-2	+		
	J4-1	-		
IB2-1 DI5	J4-4	+		
	J4-3	-		
IB2-1 DI6	J4-6	+		ESTOP
	J4-5	-		
IB2-1 DI7	J5-2	+		SYS FA
	J5-1	-		
IB2-1 DI8	J5-4	+	BAT FA	
	J5-3	-		
--	J5-5		Not Used	
--	J5-6			

Table 6.3 Relay Outputs (Factory Default) – IB2

Programmable Relay Output		IB2 Pin No.	Function	Notes	
IB2-1 DO1	NO	J6-5	The relays may be preprogrammed for specific functions. Refer to the configuration drawing (C-drawing) supplied with your system for your system's specific configuration.	<p>NOTE! The relay assigned to "Critical Summary" alarm (relay 1 on first IB2 by default) will operate in the "Fail Safe Mode". "Fail Safe Mode" means Relay 1 is de-energized during an alarm condition, opening the contacts between the C and NO terminals, and closing the contacts between the C and NC terminals.</p> <p>The remaining 7 relays energize during an alarm condition, closing the contacts between the C and NO terminals, and opening the contacts between the C and NC terminals.</p> <p>Refer to the configuration drawing (C-drawing) supplied with your system for your system's specific relay labeling.</p>	
	COM	J6-3			
	NC	J6-1			
IB2-1 DO2	NO	J6-6			
	COM	J6-4			
	NC	J6-2			
IB2-1 DO3	NO	J7-5			
	COM	J7-3			
	NC	J7-1			
IB2-1 DO4	NO	J7-6			
	COM	J7-4			
	NC	J7-2			
IB2-1 DO5	NO	J8-5			
	COM	J8-3			
	NC	J8-1			
IB2-1 DO6	NO	J8-6			
	COM	J8-4			
	NC	J8-2			
IB2-1 DO7	NO	J9-5			
	COM	J9-3			
	NC	J9-1			
IB2-1 DO8	NO	J9-6	LVD3 Control		
	COM	J9-4			
	NC	J9-2			

6.7.3 EIB (Controller Extended Interface Board) Connections (if required)

The EIB (Controller Extended Interface Board) provides additional connection points for voltage and current inputs, programmable relay outputs, and temperature probes. The EIB extended interface board is mounted inside the distribution cabinet. Refer to Figure 6.6.

Current Inputs, Voltage Inputs, and Programmable Relay Outputs

Current input, voltage input, and relay output leads are connected to screw-type terminal blocks located on the EIB. Recommended torque for these connections is 2.2 in-lbs. Refer to Figure 6.8 for terminal locations. Refer to Table 6.4, Table 6.5, and Table 6.6 for pin-out information.

Current Inputs

Connect up to three (3) shunt inputs to the EIB. Observe proper polarity. Refer to Figure 6.8 for terminal locations and Table 6.4 for pin-out information.

Refer to the NCU Instructions (UM1M830BNA) and program the shunt input parameters found in the EIB menu.



NOTE! *The shunt needs to be installed in the hot (-48V) bus. Connect the plus side of the shunt to the positive shunt input on the EIB. Connect the negative side of the shunt to the negative shunt input on the EIB.*

Voltage Inputs for Battery Block and Battery Midpoint Monitoring

The NCU can monitor battery blocks (12V blocks) or midpoint battery voltage of battery strings connected to the EIB. The EIB provides a total of eight (8) DC voltage inputs for these connections. An alarm is issued when either battery block voltage or battery midpoint voltage is abnormal. Refer to Figure 6.8 for terminal locations and Table 6.5 for pin-out information.

Refer to Figure 6.9 for connection details. Refer to the NCU Instructions (UM1M830BNA) and program the following parameters found in the EIB menu.



NOTE! *When using Battery Block Monitoring, you must make connections to all blocks.*

- **Midpoint Monitoring**

Voltage Type: Set to “Midpoint”. This selects the EIB to monitor the midpoint voltage of up to eight (8) battery strings.

BlockVDiff (Mid): This menu item appears if “Midpoint” is selected above. Set to the alarm threshold for battery midpoint monitoring per site requirements. The NCU issues an alarm when any battery midpoint voltage of any battery string has an abnormal value. The alarm is issued when the difference between any battery midpoint voltage and a reference voltage is greater than the value of the block voltage difference setting.

Block In-Use: Set to number of 12V battery blocks being used.

- **Battery Block Monitoring**

Voltage Type: Set to “48 (Block 4)”. This selects the EIB to monitor up to two (2) 48V battery strings with four (4) 12V blocks per string.

BlockVDiff (12V): This menu item appears if “48 (Block 4)” is selected above. Set to the alarm threshold for battery block monitoring per site requirements. The NCU issues an alarm when any block voltage of any battery string has an abnormal value. The alarm is issued when the difference between any block voltage and a reference voltage is greater than the value of the block voltage difference setting.

Block In-Use: Set to the number of 12V battery blocks being used.

Programmable Relay Outputs

The EIB provides five (5) programmable alarm relays with dry Form-C contacts. Connect up to five (5) relay outputs to the IB2. Refer to Figure 6.8 for terminal locations and Table 6.5 for pin-out information.

Refer to the NCU Instructions (UM1M830BNA) for programming information.

Relay Ratings: Refer to the following.

- a) Steady State: 0.5 A @ 60 VDC, 1.0 A @ 30 VDC.
- b) Peak: 3 A @ 30 VDC.

The relays may be preprogrammed for specific functions. Refer to the configuration drawing (C-drawing) supplied with your system for your system's specific configuration.

Temperature Probes

Temperature probes can be connected to the EIB (NCU Extended Interface Board) mounted inside the distribution cabinet. Refer to "Temperature Probes" on page 24.

Table 6.4 Shunt Inputs – EIB

Shunt Input	EIB Pin No.		Default Function
Sh1	J5-2	+	Load #1 Shunt
	J5-1	-	
Sh2	J5-4	+	Load #2 Shunt
	J5-3	-	
Sh3	J5-6	+	Load #3 Shunt
	J5-5	-	

Table 6.5 Voltage Inputs – EIB

Voltage Input	EIB Pin No.	Default Function
1	J6-1	Battery Block Monitoring
2	J6-2	
3	J6-3	
4	J6-4	
5	J6-5	
6	J6-6	
7	J7-1	
8	J7-3	

Table 6.6 Relay Outputs (Factory Default) – EIB

Programmable Relay Output		EIB Pin No.	Function	Notes
EIB-1 DO1	NO	J8-5	The relays may be preprogrammed for specific functions. Refer to the configuration drawing (C-drawing) supplied with your system for your system's specific configuration.	<p>NOTE! The relays energize during an alarm condition, closing the contacts between the C and NO terminals, and opening the contacts between the C and NC terminals.</p> <p>Refer to the configuration drawing (C-drawing) supplied with your system for your system's specific relay labeling.</p>
	COM	J8-3		
	NC	J8-1		
EIB-1 DO2	NO	J8-6		
	COM	J8-4		
	NC	J8-2		
EIB-1 DO3	NO	J9-5		
	COM	J9-3		
	NC	J9-1		
EIB-1 DO4	NO	J9-6		
	COM	J9-4		
	NC	J9-2		
EIB-1 DO5	NO	J7-6		
	COM	J7-4		
	NC	J7-2		

Figure 6.8 EIB (Controller Extended Interface Board) Connections

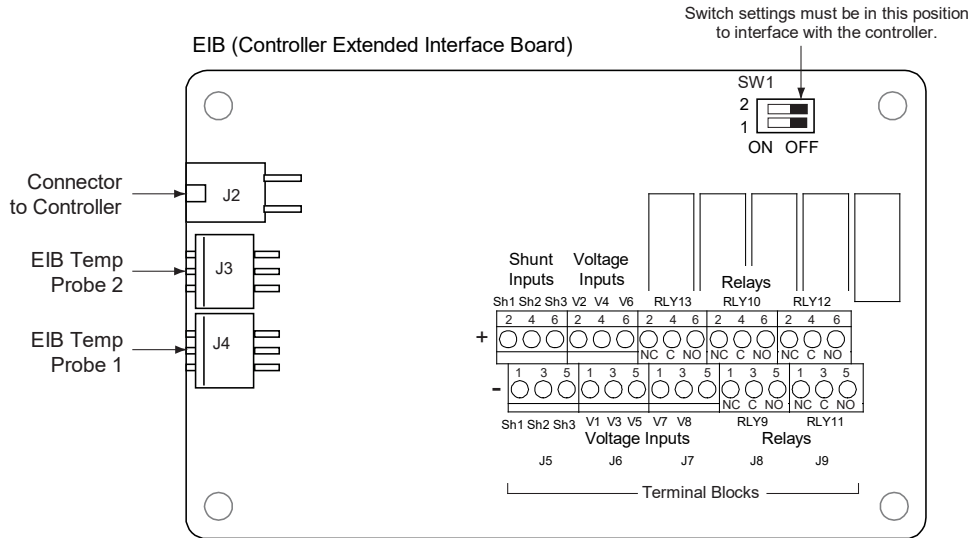
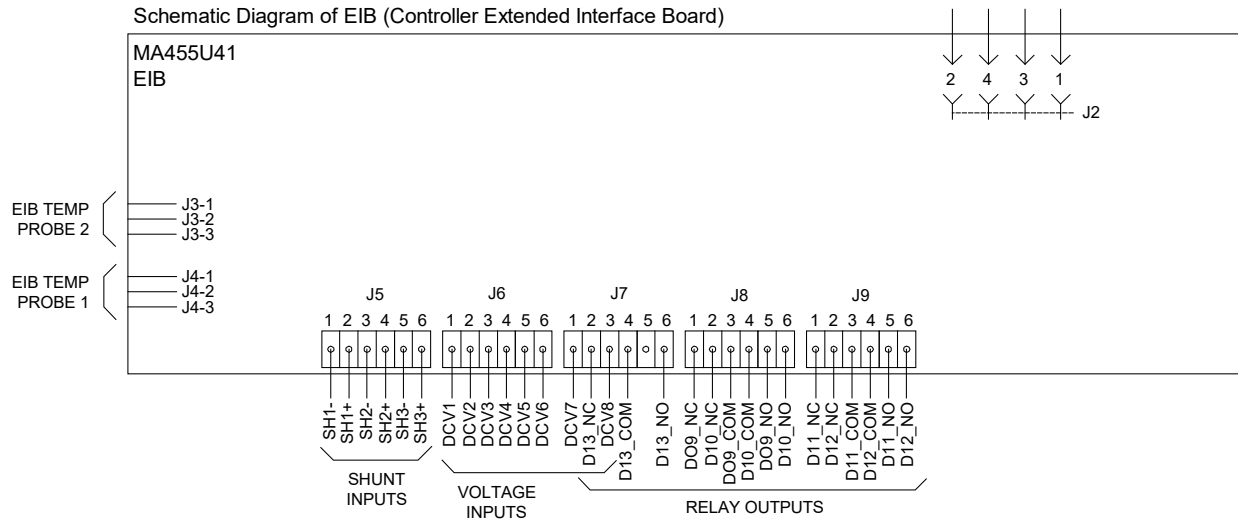

EIB Assembly

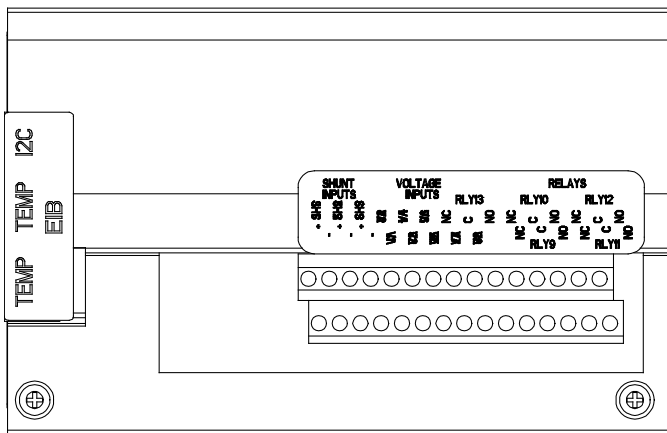

The EIB relays energize during an alarm condition, closing the contacts between the C and NO terminals, and opening the contacts between the C and NC terminals.

Refer to the configuration drawing (C-drawing) supplied with your system for your system's specific relay labeling.

Not all I/O points are available for customer connection (some are used for factory system connections).

- J5-J9:**
- Wire Size Capacity: 16 AWG to 26 AWG.
- Wire Strip Length: 0.20 inch.
- Recommended Torque: 2.2 in-lbs.

Figure 6.9 Sample Battery Block or Battery Midpoint Monitoring Connections

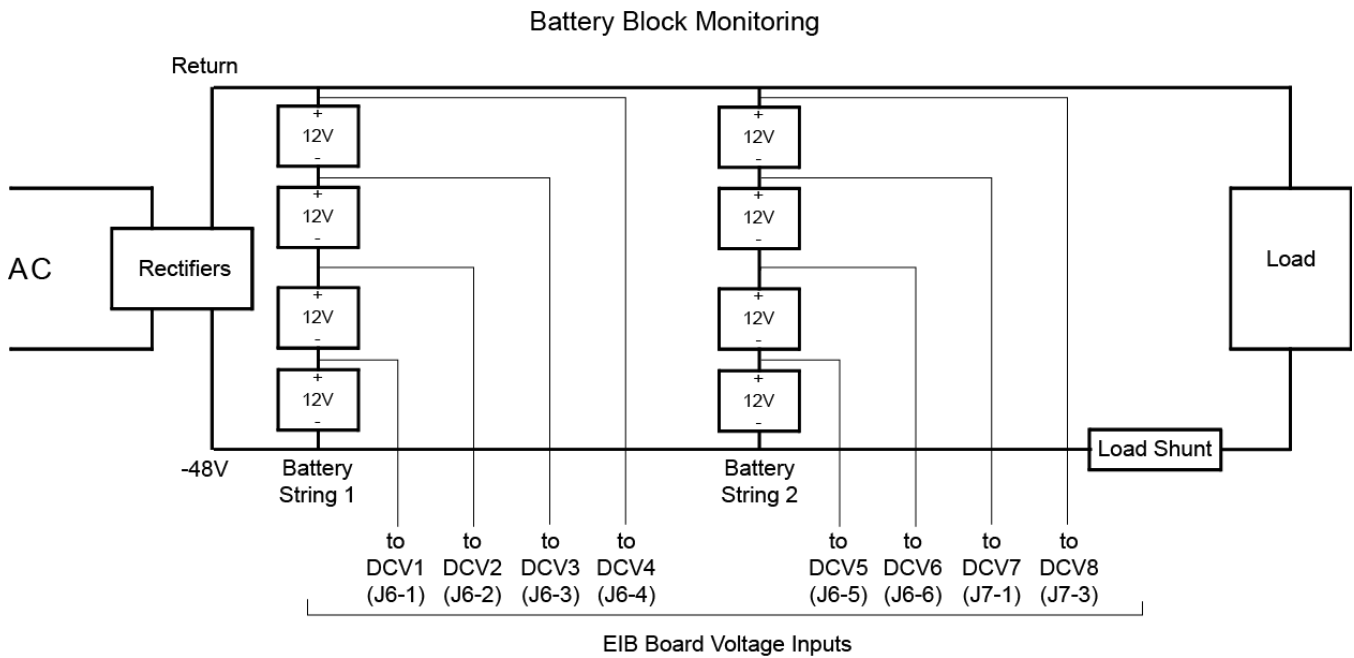
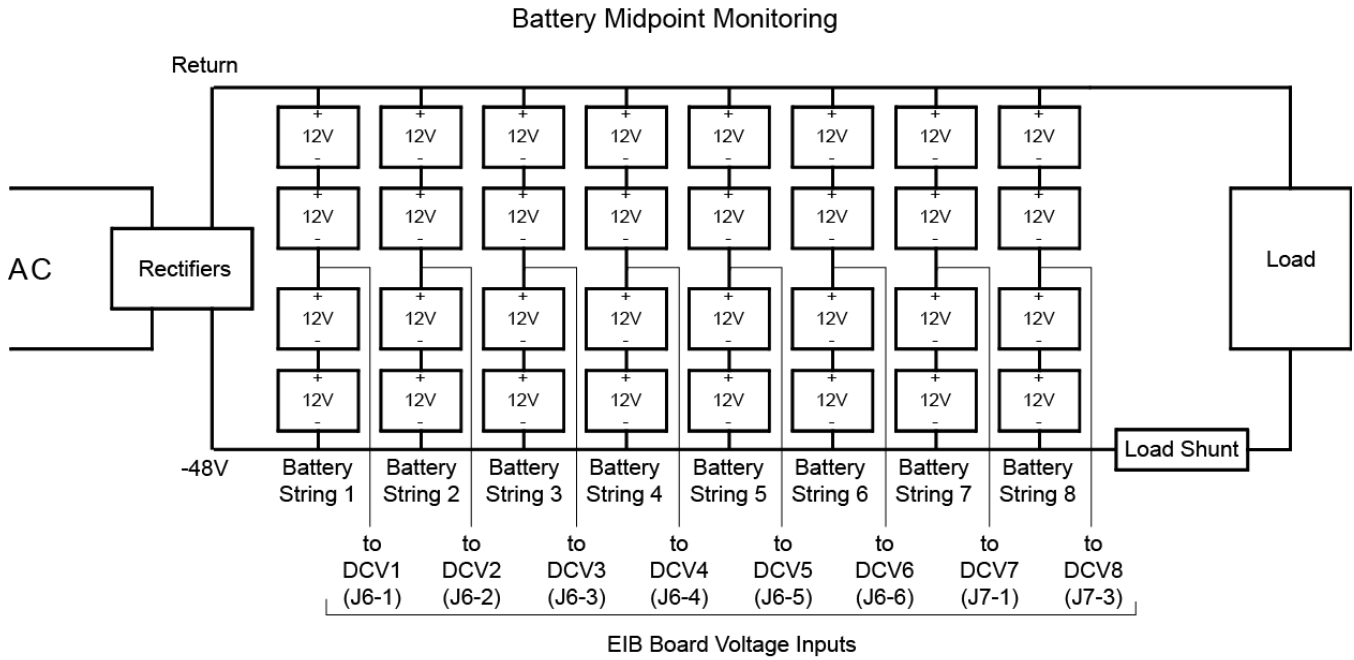

6.7.4 Connecting a Device or System to the NCU CAN Bus (if required)

A supporting device or system may be connected to the NCU CAN Port located inside the system cabinet. Refer to Figure 6.6 for location. Refer to Table 6.7 for pin-outs. Refer also to the external device's or system's instruction manual.

General Procedure

1. Remove the CAN termination plug from the CAN Port connector (see Figure 6.6 for location). Connect the device or system to the NCU Controller's CAN port. Refer to Table 6.7 for pin-outs. Ensure that the last device on the controller's CAN bus has a CAN termination plug. Refer also to the external device's or system's instruction manual.
2. Reboot the Controller

Local Menu Navigation: At the Main Screen, press ENT and ESC at the same time to reset the NCU Controller.

Web Menu Navigation: Go to Advance Settings Menu / SW Maintenance Tab / Reboot Controller button.

Optional SM-Temp Module Procedure

The analog output of the SM-Temp Module may be connected to an NCU temperature port input. In lieu of connecting the analog output of the SM-TEMP module to an NCU temperature port input, the SM-TEMP module can simply be connected at the end of the NCU CAN bus. Refer to the SM-Temp Module Instructions (UM547490) for details.

Connecting the SM-Temp Module to the Controller's CAN Bus

1. Remove the CAN termination plug from the CAN Port connector (see Figure 6.6 for location). Connect the SM-Temp Module CAN bus to the CAN Port connector, using separately ordered SM-Temp CAN Bus Interface Cable P/N 562868. Refer to Table 6.7 for pin-outs. Ensure the last SM-Temp Module (or if only one) has a CAN termination strap as shown in the SM-Temp Module Instructions (UM547490).

Table 6.7 CAN Port Connections

NCU CAN Port (RJ-45)		SM-Temp Module CAN Port Pin Number
Pin Number	Function	
1	CAN L	TB1-5 (CAN L)
2	CAN H	TB1-3 (CAN H)
3	--	--
4	--	--
5	--	--
6	--	--
7	--	--
8	--	--

6.8 NCU Controller Ethernet Connection (if required)

The NCU Controller provides a Web Interface via an Ethernet connection to a TCP/IP network. This interface can be accessed locally on a computer or remotely through a network. An RJ-45 10BaseT jack is provided on the front of the NCU for connection into a customer's network. This jack has a standard Ethernet pin configuration scheme, twisted pair. Refer to Figure 6.10 and for location and Table 6.8 for pin outs. Use shielded Ethernet cable (grounded at both ends). Note that the NCU RJ-45 jack is connected to chassis ground. Refer to the NCU Instructions (UM1M830BNA) for operational details.



NOTE! You can access the Web pages of the system locally by using a "crossover" or "straight" cable connected directly between your PC and the NCU.



WARNING! The intra-building port(s) of the equipment or subassembly is suitable for connection to intra-building or unexposed wiring or cabling only. The intra-building port(s) of the equipment or subassembly MUST NOT be metallically connected to the interfaces that connect to the OSP or its wiring. These interfaces are designed for use as intra-building interfaces only (Type 2 or Type 4 ports as described in GR-1089-CORE, Issue 4) and require isolation from the exposed OSP cabling. The addition of Primary Protectors is not sufficient protection in order to connect these interfaces metallically to OSP wiring.

The intra-building port (RJ-45) of the equipment or subassembly must use shielded intra-building cabling/wiring that is grounded at both ends.

Figure 6.10 NCU Ethernet Port

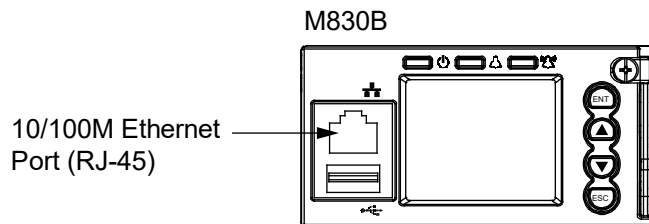

Table 6.8 NCU RJ-45 Ethernet Port Pin Configuration

Port Pin Number	Name	Definition
1	Tx+	Write Signal +
2	Tx-	Write Signal -
3	Rx+	Read Signal +
4	--	no connection
5	--	no connection
6	Rx-	Read Signal -
7	--	no connection
8	--	no connection

6.9 Load Connections

6.9.1 Important Safety Instructions



DANGER! Adhere to the “Important Safety Instructions” starting on page vi.



WARNING! Observe proper polarity when making output connections.

6.9.2 General

Load leads are connected to the individual load busbars located on the distribution panel. Load return leads are connected to the return busbar located at the top of the system cabinet. Refer to Figure 6.11, Figure 6.12, and Figure 6.13. Torque connections as shown in the illustrations.

Figure 6.11 Load Connections to 582137100101 and 582137100102

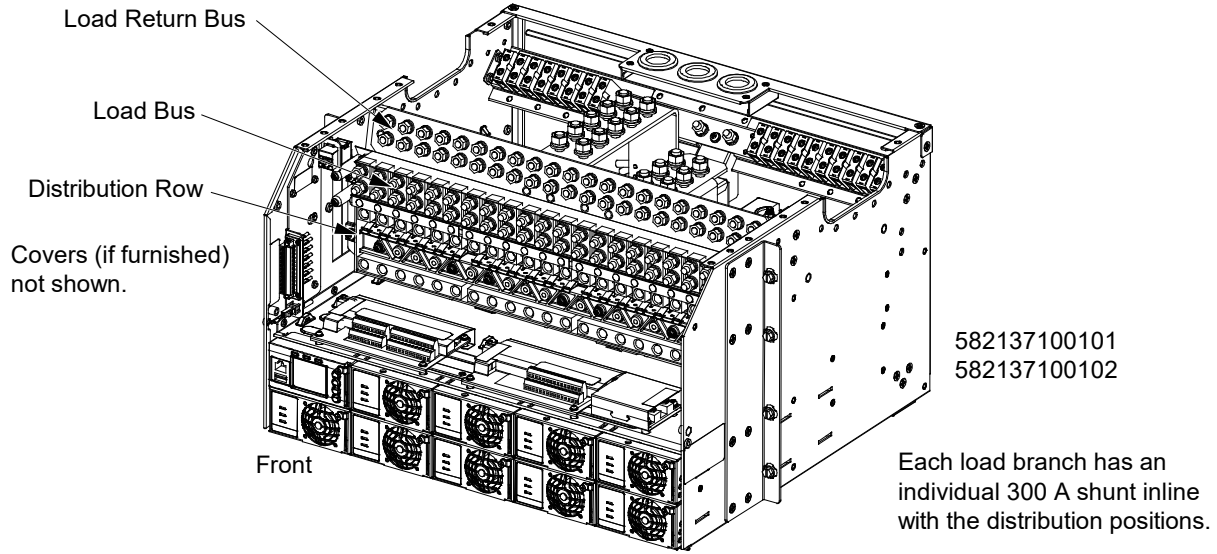

Battery disconnects with LVBD.

DO NOT install multi-pole devices across load branches.

M6 Studs on 5/8" Centers

Maximum Lug Width:
0.625 inches.

Busbar Hardware:

- M6 Hex Nut
- M6 Lock Washer
- M6 Flat Washer

Recommended Torque:
45 in-lbs.

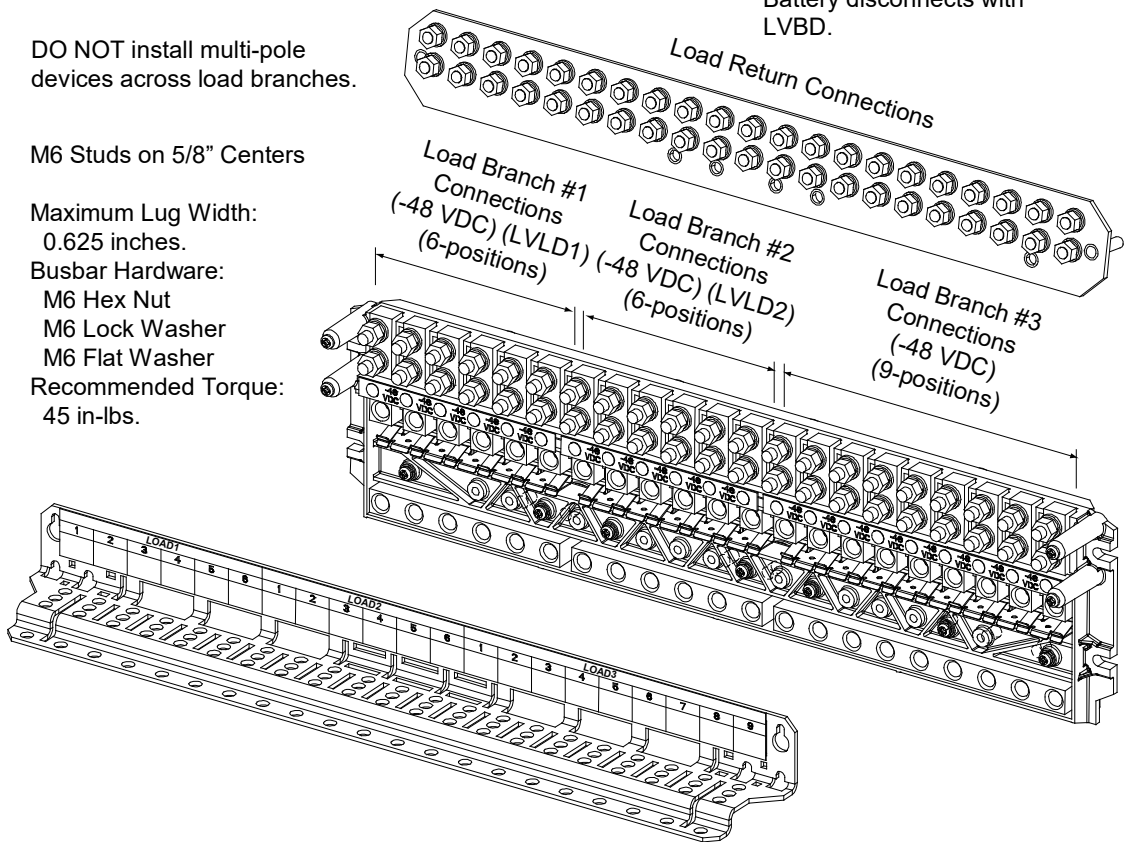
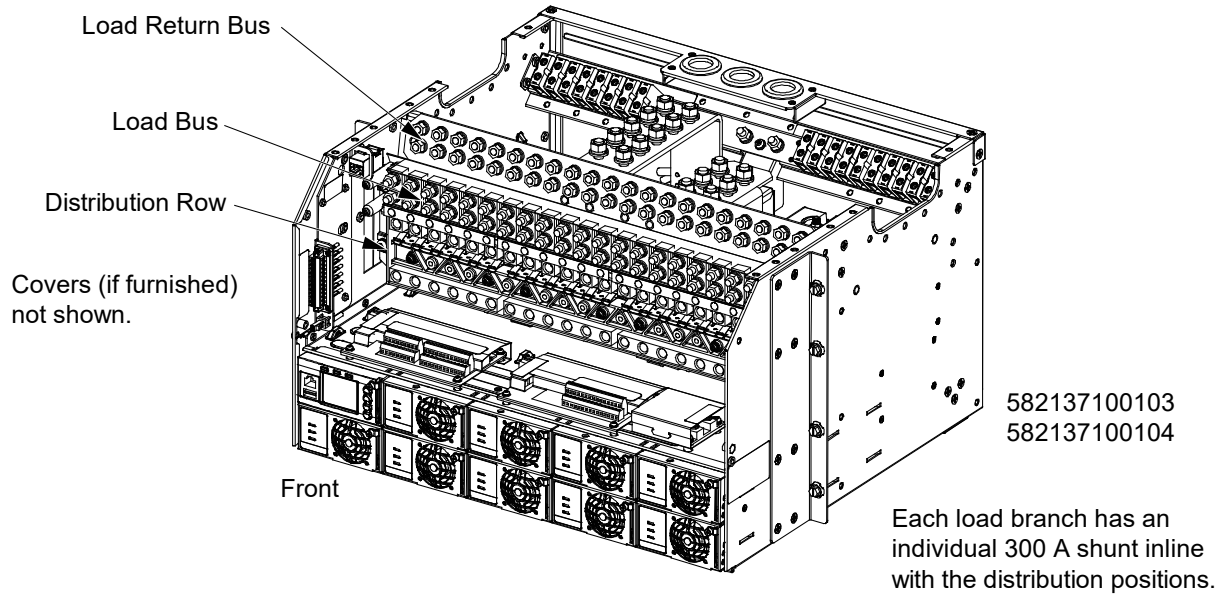

Figure 6.12 Load Connections to 582137100103 and 582137100104



DO NOT install multi-pole devices across load branches.

No LVBD.

M6 Studs on 5/8" Centers

Maximum Lug Width:
0.625 inches.

Busbar Hardware:
M6 Hex Nut
M6 Lock Washer
M6 Flat Washer

Recommended Torque:
45 in-lbs.

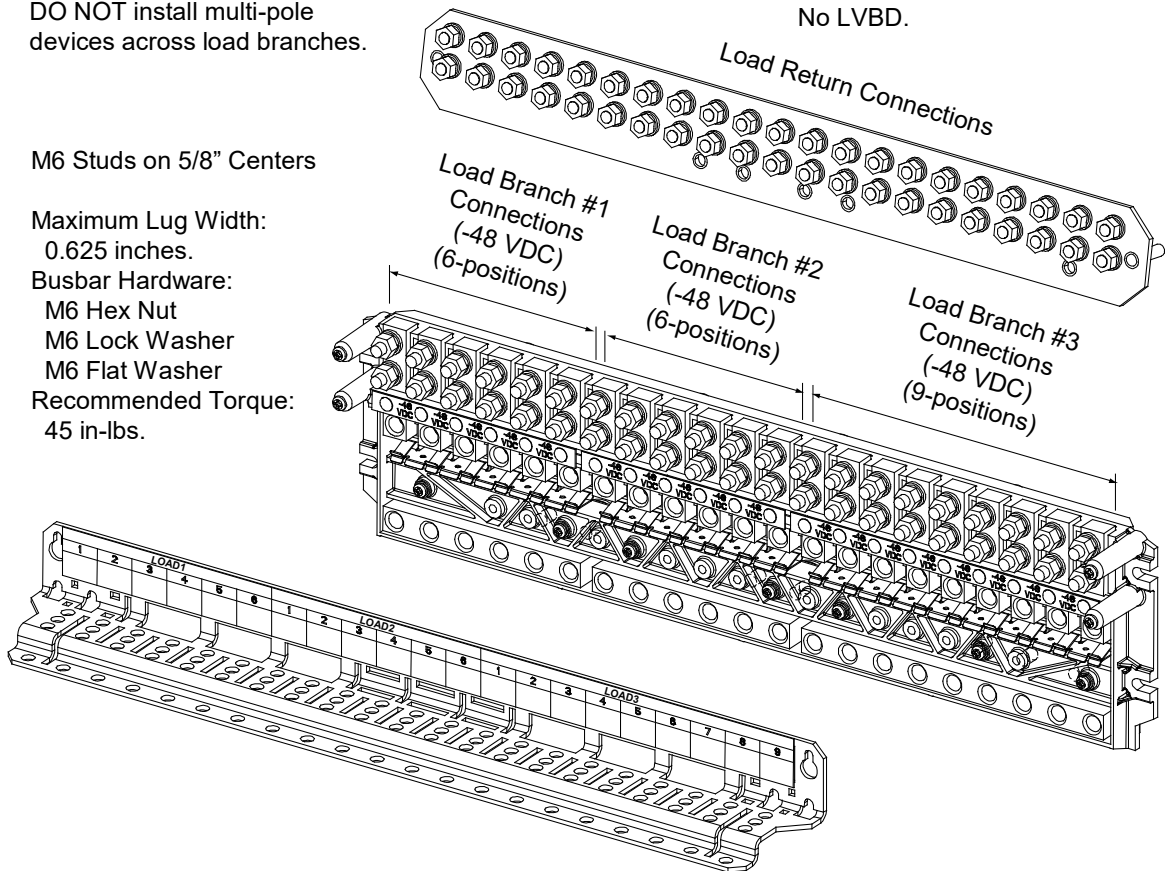
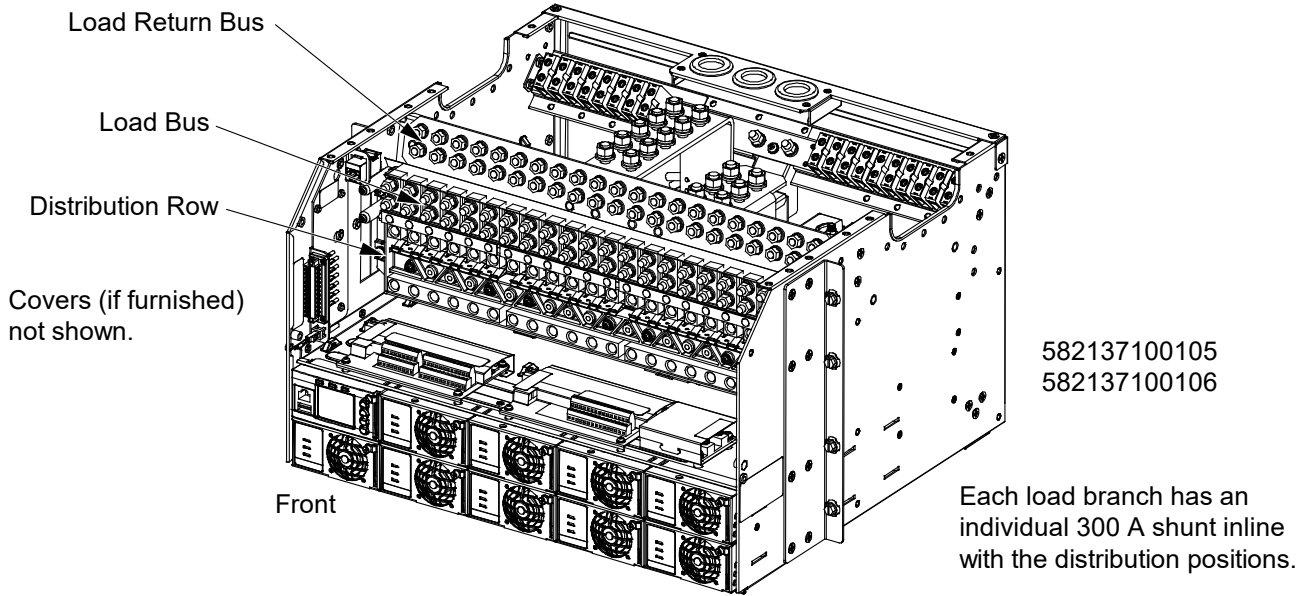

Figure 6.13 Load Connections to 582137100105 and 582137100106



Battery disconnects with LVBD.

DO NOT install multi-pole devices across load branches.

M6 Studs on 5/8" Centers

Maximum Lug Width:
0.625 inches.

Busbar Hardware:

- M6 Hex Nut
- M6 Lock Washer
- M6 Flat Washer

Recommended Torque:
45 in-lbs.

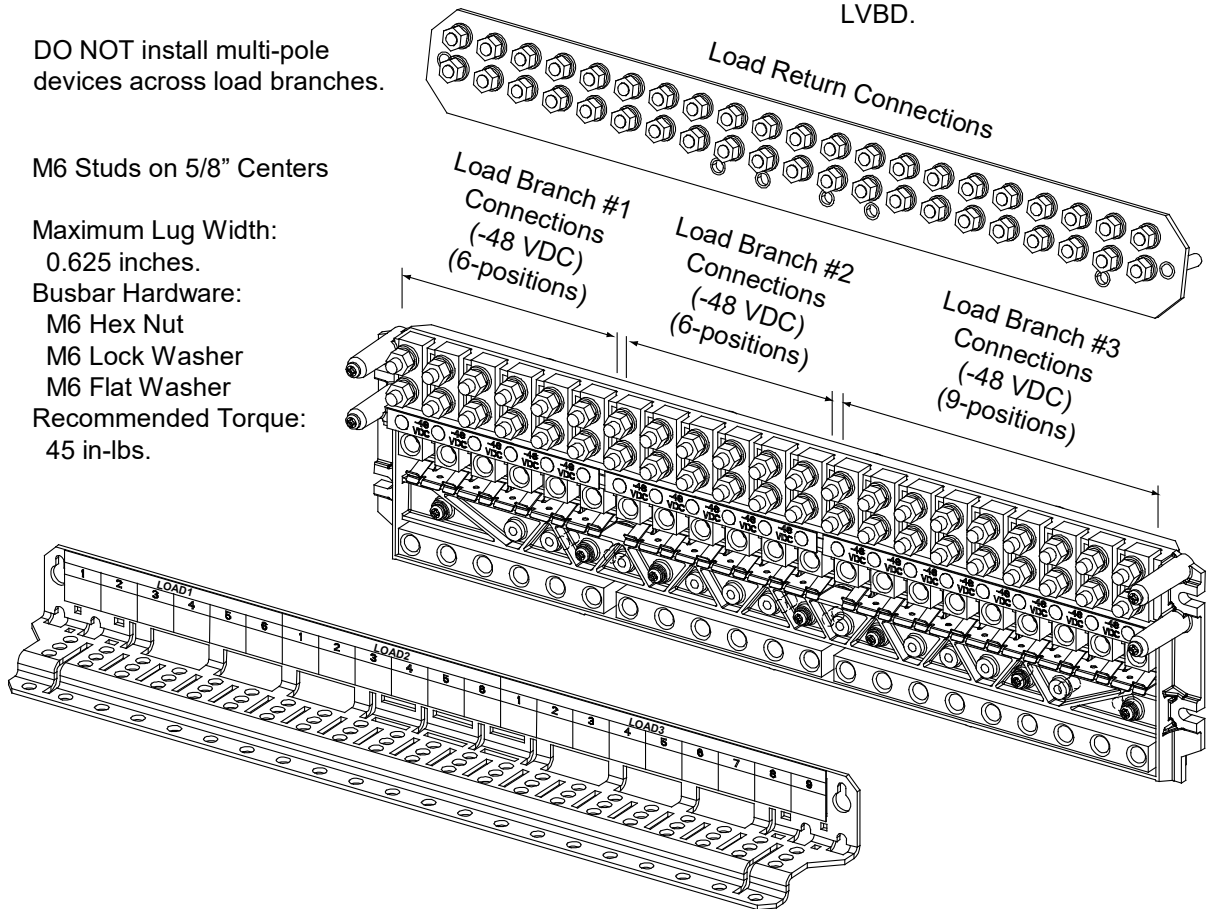

6.10 External Battery Connections

6.10.1 Important Safety Instructions



DANGER! Adhere to the “Important Safety Instructions” starting on page vi.



WARNING! Observe proper polarity when making output connections.

6.10.2 General

Input battery leads are connected to the battery (load side) busbar and battery return busbar. Refer to Figure 6.14 for connection details and recommended torque.

Figure 6.14 Battery Connections

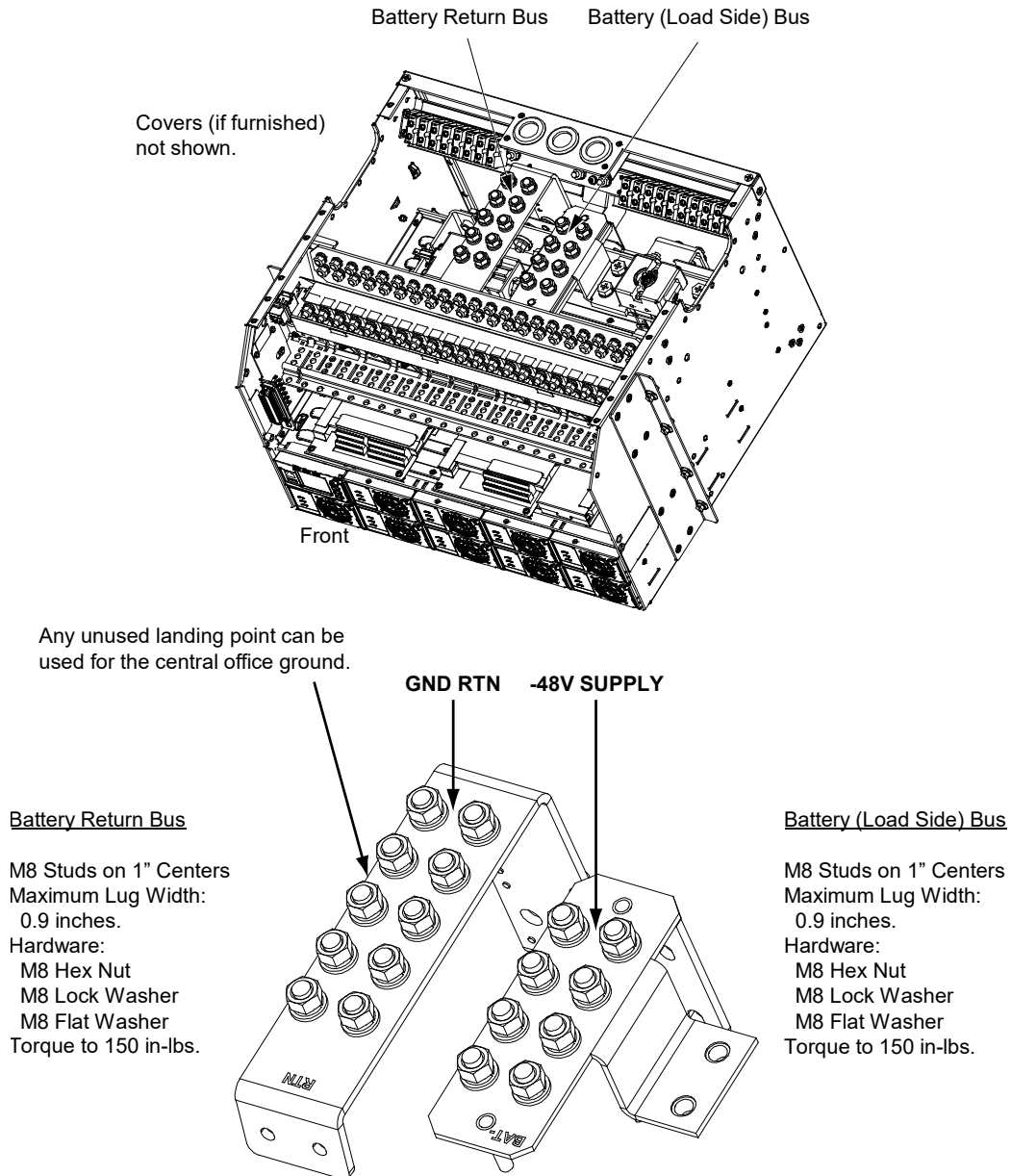

7 Installing Rectifier Modules

Refer to the rectifier instruction manual 1R483500e3 for a rectifier installation procedure.

8 Initially Starting, Configuring, and Checking System Operation

8.1 Important Safety Instructions



CAUTION! Performing various steps in the following procedures may cause a service interruption and/or result in the extension of alarms. Notify any appropriate personnel before starting these procedures. Also, notify personnel when these procedures are completed.

8.2 Initial Startup Preparation

- Ensure that all blocks (except the last one) in the Installation Acceptance Checklist on 3 have been checked.
- Ensure that rectifier mounting positions are filled by a rectifier module or a blank panel as required.
- Refer to the separate NCU User Manual supplied with your system for complete controller operating information.
- Refer to the configuration drawing (C-drawing) supplied with your system documentation for factory settings of adjustable parameters.

8.3 Initially Starting the System



NOTE! After power is initially applied to the system it takes several seconds for the rectifier modules to begin producing power and the control module initialization routine takes several minutes.

Procedure

1. Apply battery power to the system by closing the external battery disconnect(s) or protective device(s) that supplies battery power to the system, if furnished.
2. Apply rectifier AC input power to the system by closing ALL external AC disconnects or protective devices that supply rectifier AC power to the system. Rectifiers automatically start.
3. Open the distribution cabinet's front door.
4. Place each distribution circuit breaker (if furnished) to the ON position.

8.4 NCU Controller Initialization

Refer to the NCU Instructions (UM1M830BNA) for detailed instructions.

Refer to Figure 8.1 for locations of the NCU local indicators and navigation keys.

Figure 8.1 NCU Local Indicators and Navigation Keys

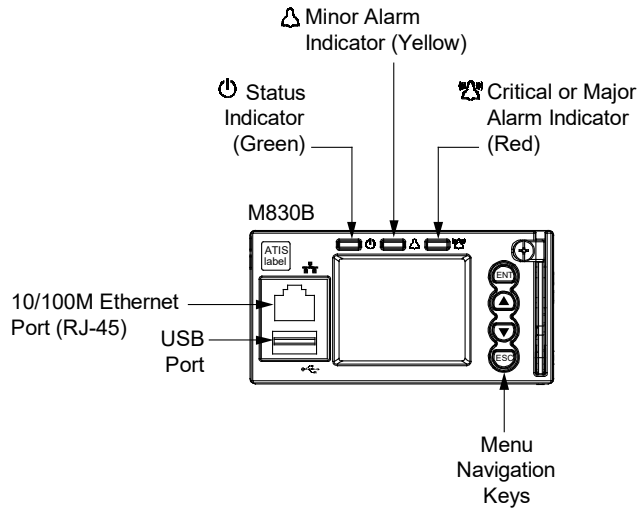

Procedure

NOTE! The initialization routine takes several minutes. During that time various alarm indicators may illuminate on the NCU front panel and an audible alarm may sound. Disregard all alarms. An audible alarm can be silenced at any time by momentarily depressing the ENT key on the NCU Controller.

1. After the NCU is powered on, the display shows the logo screen. The controller is initializing.
2. When initialization is complete, the language screen appears. Press the UP or DOWN arrow key to select the desired language. Press the ENT key to confirm the selection.
3. The Main Menu displays. See Figure 8.2.

Figure 8.2 NCU Local Display Main Menu

Main Menu

Date and time are alternately displayed.

Green - No Alarm
Red - Alarm

The number in () indicates the total number of alarms.

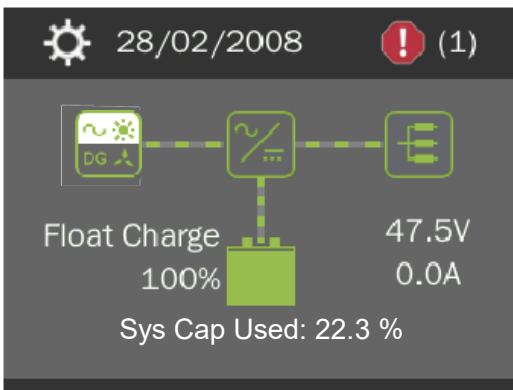

Press the UP and DOWN keys to highlight the desired Menu graphic in the Main Menu.

Press the ENT key to enter the selected menu.

Graphics	Menu Name	Description
	Alarm (Green - No Alarm) (Red - Alarm)	View active alarms and alarm history.
	Settings	Gain access to the NCU Controller's settings menus.
	Input Power	View AC, Solar, DG, and Wind related information.
	Module	View rectifier, solar converter, and converter module related information.
	DC	View DC equipments related information.
	Battery	View battery related information.

To reboot the Controller, from the Main Menu press the ENT and ESC keys at the same time. Release both keys. Press ENT to confirm.



NOTE! “Sys Cap Used” is based on the number of installed rectifiers.

4. System information is displayed in multiple screens. Press the ESC key to view other system information. Press the down arrow key to view the next screen. Press the ESC key to return to the Main Menu.
5. From the Main Menu, press the UP and DOWN keys to highlight the desired Menu graphic in the Main Menu. Press the ENT key to enter the selected menu.



NOTE! Repeatedly press the “ESC” key to return in reverse order level by level from any submenu until the Main Menu appears.

6. Refer to the following procedures to verify and set the NCU controller as required for your application.

8.5 Verifying and Setting the NCU Controller as Required for Your Application

Refer to the NCU Instructions (UM1M830BNA) for additional information.

Temperature Probes: Depending on if NCU temperature probe inputs are enabled or disabled in the NCU configuration, you may have to program the NCU for any temperature probes being used. Note that some temperature probe inputs may not be enabled by default. Refer to the C-drawing supplied with your system to determine if temperature probe inputs are enabled and pre-programmed. Refer to “Setting Temperature Sensors” in the “Common Tasks Performed via the Local Keypad and/or Web Interface” section of the NCU controller manual (UM1M830BNA) if temperature probe inputs require programming.



NOTE! Verify the NCU temperature probe configuration if temperature probes are installed from the factory. Refer to the C-drawing supplied with your system.

Refer also to “NCU Start Wizard” on page 43.



NOTE! When setting total rectifier current limit, the set point to each unit is the total set point divided by the number of units. For example, if the system contains five rectifiers and the current limit is set to 150 amps then each rectifier has a current limit set point of 30 amps. If one or more rectifiers are removed or fails it will take several seconds for the individual set points to the remaining rectifiers to be reset. In the example given, if one rectifier is removed the current limit set point will drop to 120 amps (30 amps times four remaining rectifiers) until the controller can send updated set points to the remaining rectifiers. This takes a couple communication cycles (several seconds) after which each rectifier would have a new set point of 37.5 amps for a total of 150 amps. The total current limit of the rectifiers should not be set such that the loss of the redundant rectifiers will cause this temporary set point to drop below the actual maximum expected load. If batteries are used on the rectifier output, the batteries should support the load until the current limit set points can be re-established due to loss of a rectifier.

NCU Start Wizard

For initial startup, you can perform the Start Wizard from the local keypad and display to enter basic programmable parameters in one session. Refer to the “Start Wizard” section in the NCU Instructions (UM1M830BNA).

Verifying the Configuration File

Your NCU was programmed with a configuration file that sets all adjustable parameters. The version number of the configuration file can be found on the configuration drawing (C-drawing) that is supplied with your power system documentation, and on a label located on the NCU. You can verify that the correct configuration file has been loaded into your NCU by performing the following procedure.

Procedure

1. With the Main Menu displayed, press ESC. A screen displays the NCU name, serial number, IP number, software version, hardware version, and configuration version number.
2. Press ESC to return to the Main Menu.

Checking Basic System Settings

Navigate through the controller menus and submenus to check system settings. You can adjust any parameter as required. Note that these settings can also be checked (and changed if required) via the WEB Interface. Refer also to “NCU Start Wizard” on page 43.



NOTE! Repeatedly press the “ESC” key to return in reverse order level by level from any submenu until the Main Menu appears.

Procedure

1. **To Select a Sub-Menu:**
Press the UP and DOWN keys to highlight the desired sub-menu. Press the ENT key to enter the selected sub-menu.
2. **To Select a User:**
To select a User, use the UP and DOWN keys to move the cursor to the Select User field. Press ENT. Use the UP and DOWN keys to select a User previously programmed into the NCU. Press ENT to select the User. Note that only Users programmed into the NCU are shown. Users are programmed via the Web Interface. The default User is admin.
3. **To Enter a Password:**
If a password screen opens, a password must be entered to allow the User to make adjustments. To enter a password, use the UP and DOWN keys to move the cursor to the Enter Password field. Press ENT. Use the UP and DOWN keys to choose a character. Press ENT to accept and move to the next character. Continue this process until all characters are entered. Press ENT again to accept the password. The default password is 640275.
4. **To Change a Parameter:**
Press the UP and DOWN keys to move up and down the list of parameters. Press ENT to select the parameter. Press the UP and DOWN keys to change the parameter. Press ENT to make the change. Press ESC to cancel the change.
5. Table 8.1 shows the menu navigation for some basic settings. Refer to the separate NCU Manual (UM1M830BNA) supplied with your power system for complete Local Display menus.

Table 8.1 NCU Basic Settings Menu Navigation

Parameter	Menu Navigation
Date	Main Menu / Settings Icon / Sys Settings / Date.
Time	Main Menu / Settings Icon / Sys Settings / Time.
IP Communications Parameters (IP address, subnet mask address, gateway address)	Main Menu / Settings Icon / Comm Settings / enter parameters.
Float Voltage	Main Menu / Settings Icon / Batt Settings / Charge / Float Voltage.
Equalize Voltage	Main Menu / Settings Icon / Batt Settings / Charge / EQ Voltage.
Battery Current Limit	Main Menu / Settings Icon / Batt Settings / Charge / Curr Limit Mode and Batt Curr Limit.
Battery Capacity	Main Menu / Settings Icon / Batt Settings / Batt1 Settings or Batt2 Settings / Rated Capacity.
Reset Battery Capacity	Main Menu / Settings Icon / Batt Settings / Basic Settings / Reset Batt Cap
BTRM Feature	Web Menu Navigation Only: Settings Menu / Battery Tab.
Battery Charge Temperature Compensation	Main Menu / Settings Icon / Batt Settings / Temp Comp (enter parameters).
HVSD Limit	Web Menu Navigation Only: Settings Menu / Rectifiers Tab / HVSD (set to enabled) then set HVSD Limit.
Rectifier Current Limit	Main Menu / Settings Icon / Rect Settings / Current Limit (set to enabled) then set Curr Limit Pt.
Over Voltage Alarm 1	Main Menu / Settings Icon / Other Settings / Over Voltage 1.
Over Voltage Alarm 2	Main Menu / Settings Icon / Other Settings / Over Voltage 2.
Under Voltage Alarm 1	Main Menu / Settings Icon / Other Settings / Under Voltage 1.
Under Voltage Alarm 2	Main Menu / Settings Icon / Other Settings / Under Voltage 2.

Changing Battery Capacity Rating in the NCU



NOTE! After setting the battery capacity, the User should also reset the battery capacity (battery must be fully charged).

1. Change the battery capacity setting of the NCU to match the battery connected to the power system.

Local Menu Navigation:

Main Menu / Settings Icon / Batt Settings / Batt1 Settings or Batt2 Settings / Rated Capacity.

Web Menu Navigation:

Settings Menu / Battery Tab / Batt1 Rated Capacity and Batt2 Rated Capacity.

2. Reset the battery capacity (resets the battery capacity calculation).



NOTE! Only reset the battery capacity when the battery is fully charged; otherwise, the battery charge status may not be accurate.

Local Menu Navigation:

Main Menu / Settings Icon / Batt Settings / Basic Settings / Reset Batt Cap.

Web Menu Navigation:

Settings Menu / Battery Tab / Reset Battery Capacity.

Refer to the NCU Instructions (UM1M830BNA) for detailed instructions.

Configuring the NCU Identification of Rectifiers and Assigning which Input Feed is Connected to the Rectifiers

When rectifiers are all installed prior to applying power and starting the system, the order in which the NCU identifies the rectifiers is by serial number (lowest serial number is Rect 1, next lowest is Rect 2, etc.). If you prefer the NCU to identify the rectifiers by position in the system, perform the following procedure.

Upon power up, the NCU arbitrarily assigns Feed AC1, AC2, or AC3 to each rectifier. This assignment is used to display rectifier AC input feed voltage(s). The User may reassign the feed to each rectifier per your specific installation by following the procedure below.

Local Menu Navigation:

None.

Web Menu Navigation:

Refer to the NCU Instructions (UM1M830BNA) for detailed instructions.

NCU Alarm Relay Check

The following procedures can be used to verify operation of the external alarm relays in a power system equipped with an NCU with the factory default configuration. Note that alarm relays on an NCU with a custom configuration may operate differently.



NOTE! There are two methods to check alarm relays. The first is by actually causing an alarm. The second is by using the NCU alarm relay check function. The first method is used in the following procedures.

Checking the AC Fail Alarm

Procedure



NOTE! Battery must be connected during this procedure.

1. Verify system is operating and no alarms are present.
2. Verify the NCU displays the Main Menu. If not, press ESC repeatedly to return to the Main Menu.
3. Open the external AC disconnect(s) or protective device(s) that supply power to all of the rectifier modules.
 - a) **Requirement:** An audible alarm sounds. Alarm will be silenced in Requirement d.
 - b) **Requirement:** On subject rectifier module(s), the “Protection” indicator goes from off to yellow. After approximately 30 seconds, the green “Power” and yellow “Protection” indicators go off.
 - c) **Requirement:** NCU “Critical/Major” alarm indicator goes from off to red.
 - d) **Requirement:** NCU displays “Rect AC Fail” alarm.

To see the specific alarm(s), navigate to the Alarm Menu and press **ENT**. The Active Alarm screen lists two critical alarms. “**Power System CAN Comm Fail Critical**” is displayed. Scroll down by pressing the down arrow key. “**Rect Mains Failure Critical**” is displayed.

- e) **Requirement:** External “AC Fail” (Relay 6) and “Critical” (Relay 1) alarms activate.
4. Return external AC disconnect(s) or protective device(s) to the ON position.
 - a) **Requirement:** “Power” indicator on subject rectifier modules goes from off to green.



NOTE! A “Rect Group All Rect No Response” alarm may activate briefly.

- b) **Requirement:** NCU “Critical/Major” alarm indicator goes from red to off.
- c) **Requirement:** Press ESC repeatedly to return to the Main screen. NCU displays “No Alarm”.
- d) **Requirement:** All external alarms deactivate.

Checking Rectifier Alarm

Procedure

1. Verify system is operating and no alarms are present.
2. Verify the NCU displays the Main Menu. If not, press ESC repeatedly to return to the Main Menu.
3. Pull one rectifier module half way out of the shelf. To do this, first loosen the captive fastener securing the top of the latch mechanism to the front of the rectifier module. Pull the top of the latch mechanism away from the rectifier module (this will retract the latch mechanism located on the underside of the rectifier module).
 - a) **Requirement:** An audible alarm sounds. Alarm will be silenced in Requirement c.
 - b) **Requirement:** NCU “Critical/Major” alarm indicator goes from off to red.
 - c) **Requirement:** NCU displays “Alarm”.

To see the specific alarm(s), navigate to the Alarm Menu and press **ENT**. The “Active Alarm” screen lists one major alarm. “**Rect (###) Comm Fail Major**” is displayed.

- d) **Requirement:** External “Rectifier” (Relay 8) and “Major” (Relay 2) alarms activate.



NOTE! *If the system is equipped with only one rectifier, skip step 4.*

4. Pull a second rectifier module half way out of the shelf, as described in Step 3.
 - a) **Requirement:** An audible alarm sounds. The alarm will cancel in Requirement c.
 - b) **Requirement:** NCU “Critical/Major” alarm indicator stays red.
 - c) **Requirement:** Press ESC repeatedly to return to the Main screen. NCU displays “Alarm”.

To see the specific alarm(s), navigate to the Alarm Menu and press **ENT**. The Active Alarm screen lists one critical and two major alarms. “**Rect Group Multi-Rect Fail Critical**” is displayed. Use arrow keys to scroll through the list of alarms. “**Rect ### Comm Fail Major**” is displayed for each removed rectifier.

- d) **Requirement:** External “Rectifier” (Relay 8) and “Major” (Relay 2) alarms remain in alarm state and “Critical” (Relay 1) alarm activates.
5. Reinstall the rectifier module(s).
 - a) **Requirement:** “Power” indicator on subject rectifier(s) goes from off to green.
 - b) **Requirement:** NCU “Critical/Major” alarm indicator goes from red to off.
 - c) **Requirement:** Press ESC repeatedly to return to the Main screen. NCU displays “No Alarm”.
 - d) **Requirement:** All external alarms deactivate.

Checking System Over Voltage Alarm 1 and Over Voltage Alarm 2

1. Verify system is operating and no alarms are present.
2. Verify the NCU displays the Main Menu. If not, press ESC repeatedly to return to the Main Menu.
3. Record the system voltage displayed on the NCU Main screen.
4. Navigate to the Settings Menu.
5. With the Settings menu screen displayed, navigate to “Over Voltage 1”. Main Menu / Settings Icon / Other Settings / Over Voltage 1. Record the displayed voltage setpoint.
6. Press the Enter (ENT) key; then use the UP or DOWN keys to adjust the “Over Voltage 1” value to below the system voltage recorded in step 3. Press ENT.
 - a) **Requirement:** An audible alarm sounds. The alarm will be silenced in Requirement c.
 - b) **Requirement:** NCU “Critical/Major” alarm indicator goes from off to red.
 - c) **Requirement:** Press ESC repeatedly to return to the Main Menu. NCU displays “Alarm”.

To see the specific alarm(s), navigate to the Alarm Menu and press **ENT**. The Active Alarm screen lists one critical alarm. **“Power System Over Voltage 1 Critical”** is displayed.

- d) **Requirement:** External “DC Over Voltage 1” (Relay 3) and “Critical” (Relay 1) alarms activate.
7. Without readjusting the “Over Voltage 1” setpoint, navigate to **“Over Voltage 2”**. Main Menu / Settings Icon / Other Settings / Over Voltage 2. Record the displayed voltage setpoint.
8. Press the Enter (ENT) key; then use the UP or DOWN keys to adjust the “Over Voltage 2” value to below the system voltage recorded in step 3. Press ENT.
 - a) **Requirement:** An audible alarm sounds. Alarm will be silenced in Requirement d.
 - b) **Requirement:** NCU “Critical/Major” alarm indicator stays red.
 - c) **Requirement:** Press ESC repeatedly to return to the Main Menu. NCU displays “Alarm”.

To see the specific alarm(s), navigate to the Alarm Menu and press **ENT**. The Active Alarm screen lists two critical alarms. **“Power System Over Voltage 2 Critical”** is displayed. Use arrow keys to scroll through the list of alarms. **“Power System Over Voltage 1 Critical”** is displayed.

- d) **Requirement:** External “DC Over Voltage 1” (Relay 3) alarm and “Critical” (Relay 1) alarm remain active.
9. Navigate to **“Over Voltage 2”**. Main Menu / Settings Icon / Other Settings / Over Voltage 2.
10. Press ENT; then use the UP or DOWN keys to adjust the “Over Voltage 2” setting to the value recorded in step 7. Press ENT.



NOTE! *Over Voltage 2 alarm will retire. The audible alarm will be silenced in the next step.*

11. Use the UP or DOWN keys to scroll up to **“Over Voltage 1”**.
12. Press ENT; then use the UP or DOWN keys to adjust the “Over Voltage 1” setting to the value recorded in step 5. Press ENT.
 - a) **Requirement:** NCU “Critical/Major” alarm indicator goes from red to off.

- b) **Requirement:** Press ESC repeatedly to return to the Main screen. NCU displays “No Alarm”.
- c) **Requirement:** All external alarms deactivate.

Checking System Under Voltage Alarm 1 and Under Voltage Alarm 2

1. Verify system is operating and no alarms are present.
2. Verify the NCU displays the Main Menu. If not, press ESC repeatedly to return to the Main Menu.
3. Record the system voltage displayed on the NCU Main screen.
4. Navigate to the Settings Menu.
5. With the Settings Menu screen displayed, navigate to **“Under Voltage 1”**. Main Menu / Settings Icon / Other Settings / Under Voltage 1. Record the displayed voltage setpoint
6. Press the Enter (ENT) key; then use the UP or DOWN keys to adjust the “Under Voltage 1” value to above the system voltage recorded in step 3. Press ENT.
 - a) **Requirement:** An audible alarm sounds. The alarm will be silenced in Requirement c.
 - b) **Requirement:** NCU “Critical/Major” alarm indicator goes from off to red.
 - c) **Requirement:** Press ESC repeatedly to return to the Main screen. NCU displays “Alarm”.

To see the specific alarm(s), navigate to the Alarm Menu and press **ENT**. The Active Alarm screen lists one critical alarm. **“Power System Under Voltage 1 Critical”** is displayed.

- d) **Requirement:** External “DC Under Voltage 1” (Relay 4) and “Critical” (Relay 1) alarms activate.
7. Without readjusting the “Under Voltage 1” setpoint, navigate to **“Under Voltage 2”**. Main Menu / Settings Icon / Other Settings / Under Voltage 2. Record the displayed voltage setpoint.
 8. Press the Enter (ENT) key; then use the UP or DOWN keys to adjust the “Under Voltage 2” value to above the system voltage recorded in step 3. Press ENT.
 - a) **Requirement:** An audible alarm sounds. Alarm will be silenced in Requirement c.
 - b) **Requirement:** NCU “Critical/Major” alarm indicator stays red.
 - c) **Requirement:** Press ESC repeatedly to return to the Main screen. NCU displays “Alarm”.

To see the specific alarm(s), navigate to the Alarm Menu and press **ENT**. The Active Alarm screen lists two critical alarms. **“Power System Under Voltage 2 Critical”** is displayed. Use arrow keys to scroll through the list of alarms. **“Power System Under Voltage 1 Critical”** is displayed.

- d) **Requirement:** External “DC Under Voltage 2” (Relay 5) alarm activates, “DC Under Voltage 1” (Relay 4) alarm resets, and “Critical” (Relay 1) alarm remains active.
9. Navigate to **“Under Voltage 2”**.
 10. Press ENT; then use the UP or DOWN keys to adjust the “Under Voltage 2” setting to the value recorded in step 7. Press ENT.



NOTE! Low Voltage 2 alarm will retire. The audible alarm will be silenced in the next step.

11. Use the UP or DOWN keys to scroll up to **“Under Voltage 1”**.
12. Press ENT; then use the UP or DOWN keys to adjust the “Under Voltage 1” setting to the value recorded in step 5. Press ENT.
 - a) **Requirement:** NCU “Critical/Major” alarm indicator goes from red to off.
 - b) **Requirement:** Press ESC repeatedly to return to the Main screen. NCU displays **“No Alarm”**.
 - c) **Requirement:** All external alarms deactivate.

Checking Circuit Breaker Alarm



NOTE! For all systems equipped with battery disconnect circuit breakers, an open battery disconnect circuit breaker will not activate the circuit breaker alarm unless a battery (or a temporary test load) is connected to the system battery terminals. The battery fuse input is looking for a delta voltage across a battery circuit breaker to activate the alarm. You will not have a reference if there is no battery (or a temporary test load) connected.

1. Verify system is operating and no alarms are present.
2. Verify the NCU displays the Main Menu. If not, press ESC repeatedly to return to the Main Menu.
3. Open the front door of the distribution unit at the right-hand side of the shelf.



NOTE! The following procedure is to be used only with circuit breakers that provide an alarm indication when manually placed to the OFF (open) position (black handle). Electrical trip alarm circuit breakers (white handle) cannot be easily tested in the field.

4. Place the handle (if black) of a load circuit breaker in the OFF (open) position.
 - a) **Requirement:** An audible alarm sounds. The alarm will be silenced in Requirement c.
 - b) **Requirement:** NCU “Critical/Major” alarm indicator goes from off to red.
 - c) **Requirement:** NCU displays **“Alarm”**.

To see the specific alarm(s), navigate to the Alarm Menu and press **ENT**. The Active Alarm screen lists one critical alarm. **“Power System Load Brkr Critical”** is displayed.







- d) **Requirement:** External “Circuit Breaker Alarm” (Relay 7) and “Critical” (Relay 1) alarms activate.
5. Place the handle of the circuit breaker in the ON (closed) position.
 - a) **Requirement:** NCU “Critical/Major” alarm indicator goes from red to off.
 - b) **Requirement:** Press ESC repeatedly to return to the Main screen. NCU displays **“No Alarm”**.
 - c) **Requirement:** All external alarms deactivate.

8.6 Checking System Status

Procedure

1. Observe the status of the indicators located on the controller, rectifiers, solar converters, and -48 VDC to +24 VDC converters (if furnished). If the system is operating normally, the status of these is as shown in Table 8.2.

Table 8.2 Status and Alarm Indicators

Component	Indicator	Indicator	Normal State
NCU		Status (Green)	On
		Minor Alarm (Yellow)	Off
		Critical or Major Alarm (Red)	Off
Rectifier Modules		Power (Green)	On
		Protection (Yellow)	Off
		Alarm (Red)	Off

8.7 Final Steps

Procedure

1. If any controller configuration settings were changed, refer to the NCU Instructions (UM1M830BNA) and save a copy of the configuration file. This file can be used to restore the controller settings, if required, at a later date.
2. Verify all rectifier modules and the controller are fully seated, latched, and the latch handle screws secured.
3. Verify there are no external alarms and the local indicators are as shown in Table 8.2.

9 Operating Procedures

9.1 Rectifiers and Controller

For operation instructions on these units, refer to the following documents.

- Rectifier Instructions (UM1R483500E3)
- NCU Controller Instructions (UM1M830BNA)



NOTE! The controller's default "User Name" is "admin" and the default "Password" is "640275".

9.2 ESTOP Function

If an ESTOP switch is wired to the IB2-1 Controller Interface Board, customer-furnished system ground applied to terminal DI8+ activates the ESTOP function. The ESTOP function shuts down and locks out the rectifiers and opens the optional low voltage disconnect (LVD) contactors (battery and load type). If the system does not contain a battery LVD, the controller will remain

operational. If the system does not contain battery or load LVD(s) and has battery connected, the loads will be sustained by the battery voltage.

When the ESTOP signal is removed, load LVD's will close if battery voltage is present on the bus (system does not contain a battery LVD). Rectifiers will remain off. The rectifiers will restart when the input power is removed and restored after 30 seconds or more (until the LEDs on the modules extinguish).



NOTE! *If a customer-furnished method to disconnect the input power to the system is not provided, the rectifiers will stay locked OFF until the input power is recycled. If the ESTOP signal is removed without recycling the input power, the rectifiers will remain off and have a local alarm visible on the module. The ESTOP alarm from the controller will extinguish. The controller will not issue an alarm for this condition.*

9.3 Controller Battery Charge Current Limit Feature

Functionality: After a failure of the input source (commercial AC) or when some battery cells are permanently damaged, the current to the batteries can be quite extensive. To avoid overheating or further damages to the battery, the controller can be programmed to limit the battery current to a preset level by limiting the charging voltage of the rectifiers. Should the battery current still exceed a higher preset value, an alarm is issued.

The controller limits the current going to the batteries based on the "Battery Current Limit" set point which is a percentage of the battery capacity in C10. For example, 0.1C10 would mean 10% of the battery capacity. If the C10 capacity of a battery is 100 amp-hr, the battery recharge current limiting setpoint is 0.1C10; therefore, the recharge current is limited to 10 A.

Refer to the NCU Controller Instructions (UM1M830BNA) to program this feature. Battery charge current is limited to the value set in the controller, as long as battery voltage is above 47 VDC.

9.4 Local Controls and Indicators

Rectifiers and Controller

Refer to the rectifier and controller instructions for descriptions of the local controls and indicators located on these units.

10 Maintenance

10.1 System Maintenance Procedures

It is recommended to perform the maintenance procedures listed in Table 10.1 every 6-months to ensure continual system operation.

Table 10.1 Maintenance Procedures to be Performed at 6-Month Intervals

Procedure	Referenced In
Check ventilation openings for obstructions such as dust, papers, manuals, etc.	--
Inspect and tighten all installer's connections.	See "Making Electrical Connections" starting on page 16.

10.2 Adding a Rectifier

To increase system current capacity, a rectifier can easily be added to an existing empty rectifier mounting position.

Refer to Rectifier Instructions UM1R483500E3 for a rectifier installation procedure.

11 Troubleshooting and Repair

11.1 Contact Information

Refer to Section 4-154 (provided with your customer documentation) for support contact information.

11.2 Rectifiers and Controller

For troubleshooting and repair instructions on these units, refer to the following documents.

- Rectifier Instructions (UM1R483500E3)
- NCU Controller Instructions (UM1M830BNA)

11.3 Controller Configuration

If any controller configuration settings were changed, refer to the NCU Controller Instructions (UM1M830BNA) and save a copy of the configuration file. This file can be used to restore the controller settings, if required, at a later date.

11.4 System Troubleshooting Information

This system is designed for ease in troubleshooting and repair. The various indicators as described in “Local Controls and Indicators” on page 52 and in the rectifier and controller instructions are designed to isolate failure to a specific element. Once the faulty element has been identified, refer to “Replacement Information” on page 54 and “Replacement Procedures” on page 54.

Troubleshooting Alarm Conditions on the Controller

The controller displays alarm conditions as listed in the “Resolving Alarms” section of the controller’s User Manual. Programmable external alarm relays are also available. Refer to “External Alarm, Reference, Monitoring, and Control Connections” starting on page 23 and the Controller Configuration Drawing (C-drawing) supplied with your system documentation for your alarm relay configurations.

The controller’s Active Alarm and Alarm History submenus allow the User to view alarm details. Refer to the NCU Controller Instructions (UM1M830BNA) to access these menus.

Checking the Controller’s Current Limit Point after Adding or Removing a Rectifier

If a rectifier is added; the respective current limit point in amps will automatically increase to maintain the same percentage. For example, if the current limit was set to 100% of combined capacity and a rectifier is added, the new current limit setpoint will be 100% of the combined capacity including the new rectifier.

If a rectifier is removed from the system (and the Rect Comm Fail is cleared), the current limit point will remain unchanged unless the capacity of the remaining rectifiers is not sufficient to maintain this current limit point. If that happens, the current limit point will automatically decrease to the maximum (121% of the remaining rectifiers).

It is recommended that the current limit point be checked whenever a rectifier is added to or removed from the system.

When setting total rectifier current limit, the set point to each rectifier is the total set point divided by the number of rectifiers. For example, if the system contains five rectifiers and the current limit is set to 150 amps then each rectifier has a current limit set point of 30 amps. If one or more rectifiers are removed or fails it will take several seconds for the individual set points to the remaining rectifiers to be reset. In the example given, if one rectifier is removed the current limit set point will drop to 120 amps (30 amps times four remaining rectifiers) until the controller can send updated set points to the remaining rectifiers. This takes a couple communication cycles (several seconds) after which each rectifier would have a new set point of 37.5 amps for a total of 150 amps. The total current limit of the rectifiers should not be set such that the loss of the redundant rectifiers will cause this temporary set point to drop below the actual maximum expected load. If batteries are used on the rectifier output, the batteries should support the load until the current limit set points can be re-established due to loss of a rectifier.

Refer to the NCU Controller Instructions (UM1M830BNA) for a procedure.

Clearing a Rectifier Communications Fail Alarm after Removing a Rectifier

If a rectifier is removed from the system, a rectifier communications failure alarm is generated. If the rectifier will not be replaced, the alarm should be cleared.

Refer to the NCU Controller Instructions (UM1M830BNA) for a procedure.

Clearing a Rectifier Lost Alarm

If the controller resets while a rectifier communications fail alarm is active, the rectifier communications fail alarm is replaced with a rectifier lost alarm.

Refer to the NCU Controller Instructions (UM1M830BNA) for a procedure to clear the alarm.

11.5 Replacement Information

Replacement Assemblies

When a trouble symptom is localized to a faulty rectifier, controller, or system circuit card; that particular device or circuit card should be replaced in its entirety. No attempt should be made to troubleshoot or repair individual components on any rectifier, controller, or circuit card.

Refer to System Application Guide SAG582137100101 / SAG582137100102 / SAG582137100103 / SAG582137100104 / SAG582137100105 / SAG582137100106 for replacement part numbers.

11.6 Replacement Procedures

11.6.1 Important Safety Instructions



DANGER! Adhere to the “Important Safety Instructions” starting on page vi.

11.6.2 Replacing a Rectifier

Refer to the Rectifier Instructions (UM1R483500E3) for a rectifier replacement procedure. Refer also to “System Troubleshooting Information” on page 53.

The rectifier being replaced is assigned by the NCU the lowest available identification number. If desired, you can change the identification number, see “Configuring the NCU Identification of Rectifiers and Assigning which Input Feed is Connected to the Rectifiers” on page 46.

11.6.3 Replacing the NCU Controller

Refer to the NCU Controller Instructions (UM1M830BNA) for a controller replacement procedure.

11.6.4 Replacing a Distribution Device

Replace distribution devices with the same type and rating. Refer to System Application Guide SAG582137100101 / SAG582137100102 / SAG582137100103 / SAG582137100104 / SAG582137100105 / SAG582137100106 for part numbers.

Replacing a Bullet Nose Circuit Breaker

Procedure



NOTE! Refer to Figure 11.1 as this procedure is performed.

1. Operate the defective circuit breaker to the OFF position.

2. Gently rock the defective circuit breaker up and down while pulling firmly outward until the breaker is free from the distribution panel.
3. Ensure that the replacement circuit breaker is in the OFF position, and is of the correct rating.
4. Orient the circuit breaker as shown in Figure 11.1. Insert the terminals on the rear of the circuit breaker into their corresponding sockets on the distribution panel. Ensure the alarm contact on the back of the circuit breaker makes contact with the alarm terminal on the spring strip. Push distribution device in firmly until fully seated in the distribution panel.
5. Operate the replacement circuit breaker to the ON position.
6. Verify no circuit breaker alarms are active.

Figure 11.1 Replacing a Bullet Nose Circuit Breaker

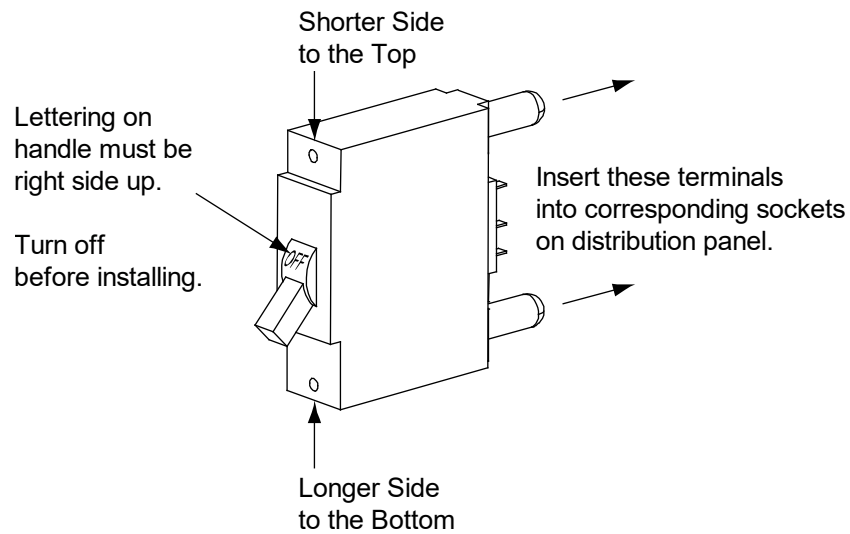

11.6.5 Circuit Card Replacement Procedures

Important Safety Instructions



DANGER! Adhere to the “Important Safety Instructions” starting on page vi.



WARNING! Circuit cards used in this system contain static-sensitive devices. Read the “Static Warning” from the document Section 4-154 (provided with your customer documentation) before performing any of the following procedures.

General

The following circuit card replacement procedures can be performed with the system operating.

Circuit Card Locations

Refer to Figure 11.2.

Figure 11.2 Circuit Card Locations

582137100101 Shown, others similar

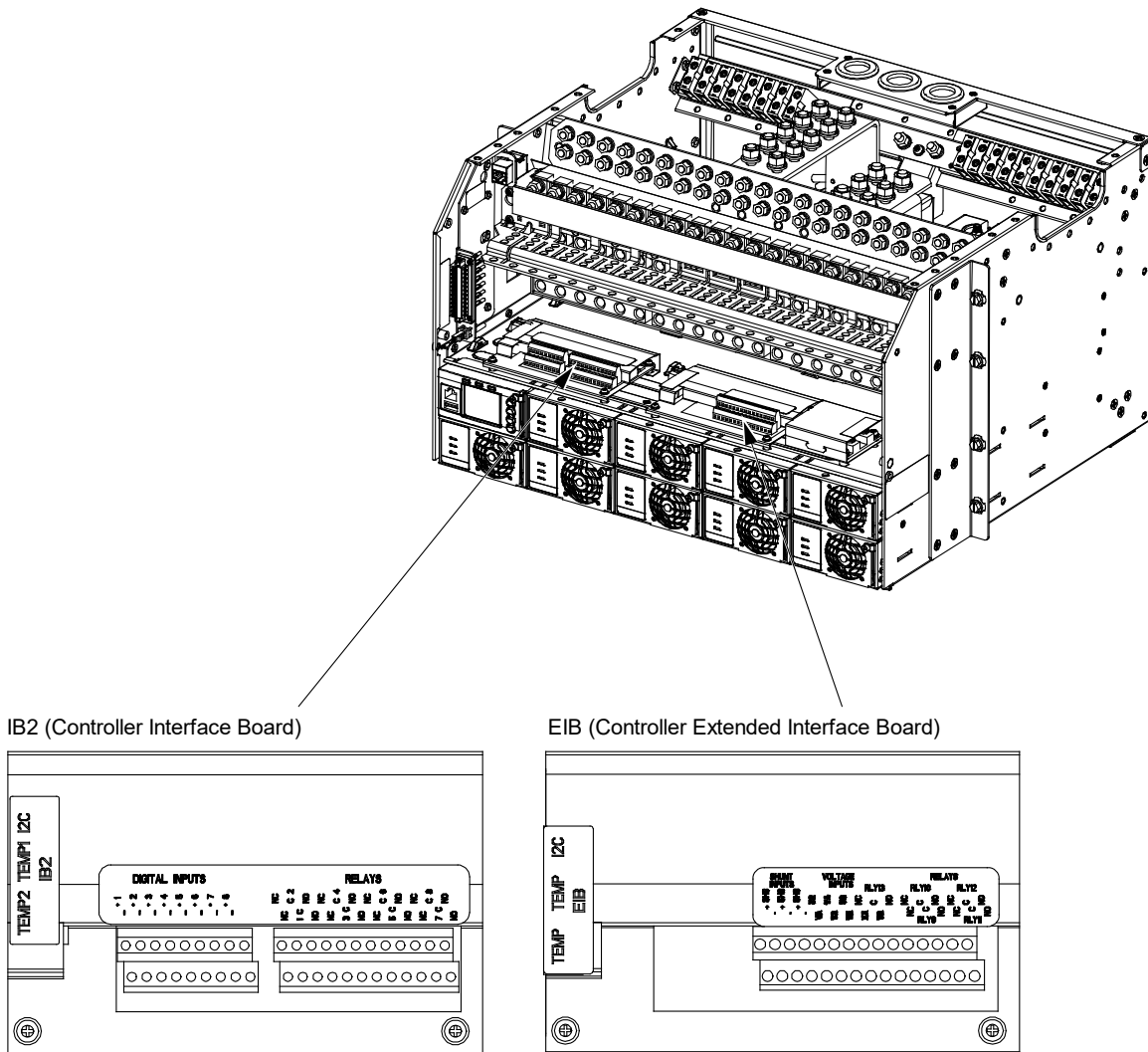

Replacing the IB2 (Controller Interface Board) or Optional EIB (Controller Extended Interface Board)

Procedure



NOTE! Refer to Figure 11.2 for circuit card locations. Refer to Figure 11.3 or Figure 11.4 as this procedure is performed.

1. Performing this procedure may activate external alarms. Do one of the following. If possible, disable these alarms. If these alarms cannot be easily disabled, notify the appropriate personnel to disregard any future alarms associated with this system while the procedure is being performed.



DANGER! Performing the next steps exposes service personnel to battery potential. Exercise extreme caution not to inadvertently contact or have any tool inadvertently contact any energized electrical termination.



WARNING! Damage to the circuit card may result if the next step is not followed.

2. Connect an approved grounding strap to your wrist. Attach the other end to a suitable ground.
3. Open the system cabinet's front door, if furnished.
4. Carefully label the wires connected to the customer connection terminal blocks on the circuit card. These wires must be connected to the same terminals on the replacement circuit card. Refer to Figure 11.3 or Figure 11.4.
5. Carefully label the connectors plugged into the circuit card. These connectors must be plugged into the same connectors on the replacement circuit card. Refer to Figure 11.3 or Figure 11.4.



DANGER! In the next step, external alarm wiring may be energized from an external source. DO NOT allow bare wire ends to contact any grounded or energized object.

6. Remove the external wiring from the customer connection terminal blocks. DO NOT allow the bare wire end to contact any grounded or energized object. Isolate the wire end with electrical tape. Repeat for each wire to be removed.
7. Unplug all connectors plugged into the circuit card.
8. Remove the circuit card (and shield) from the system cabinet by removing the screws securing it to the cabinet. See Figure 11.3 or Figure 11.4.
9. In this step, ensure you do not intermix the old and replacement circuit cards. Set the switch on the replacement circuit card to the same setting as the old circuit card. Switch settings are documented in "Setting Switch Options" starting on page 13.
10. Secure the replacement circuit card (and shield) to the system cabinet. See Figure 11.3 or Figure 11.4.
11. Plug all connectors removed from the old circuit card into the same position on the replacement circuit card.



DANGER! In the next step, external alarm wiring may be energized from an external source. DO NOT allow bare wire ends to contact any grounded or energized object.

12. Reconnect the external wiring to the correct terminals on the customer connection terminal block. First remove the electrical tape that was applied to the bare wire end in a previous step. DO NOT allow the bare wire end to contact any grounded or energized object. After securing the wire, gently tug on the wire to ensure that it cannot be pulled out of the terminal block. Repeat for each wire to be reconnected.
13. Remove the grounding wrist strap.
14. Close the system cabinet's front door, if furnished.

15. Reboot the Controller

Local Menu Navigation: At the Main Screen, press ENT and ESC at the same time to reset the NCU Controller.

Web Menu Navigation: Go to Advance Settings Menu / SW Maintenance Tab / Reboot Controller button.

16. Enable the external alarms, or notify appropriate personnel that this procedure is finished.
17. Ensure that there are no local or remote alarms active on the system.

Figure 11.3 Replacing an IB2 (Controller Interface Board) Circuit Card

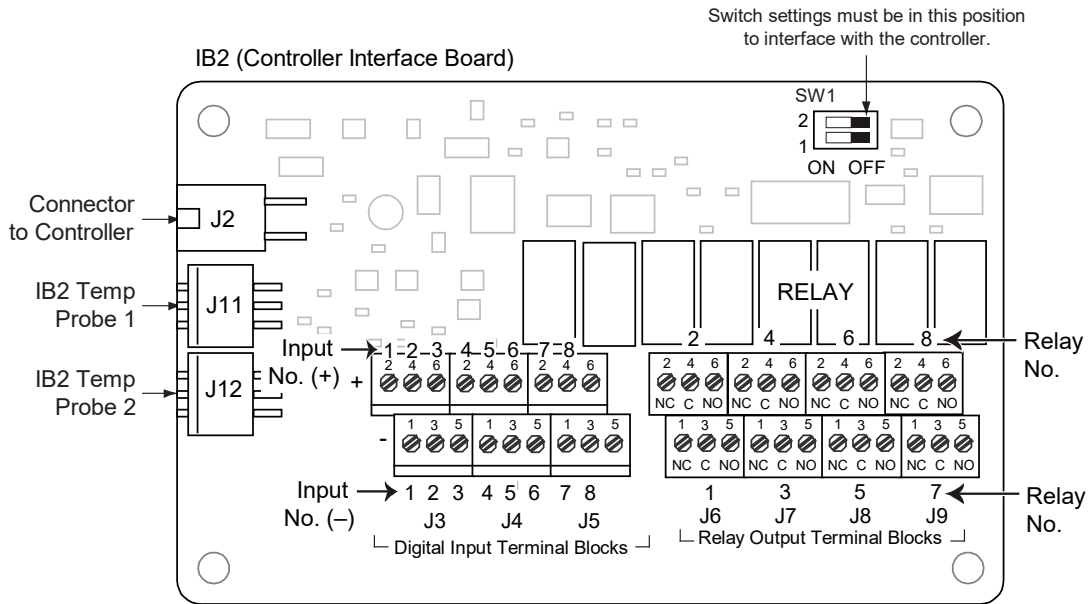

J3-J9:
 Wire Size Capacity: 16 AWG to 26 AWG.
 Wire Strip Length: 0.20 inch.
 Recommended Torque: 2.2 in-lbs.

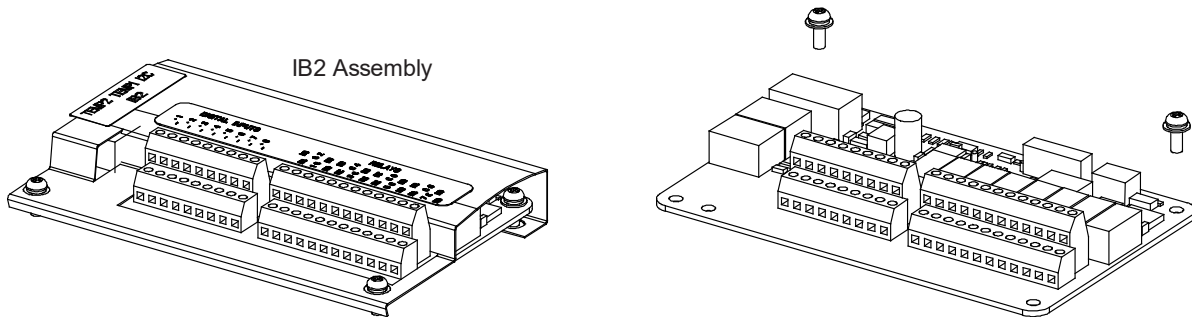
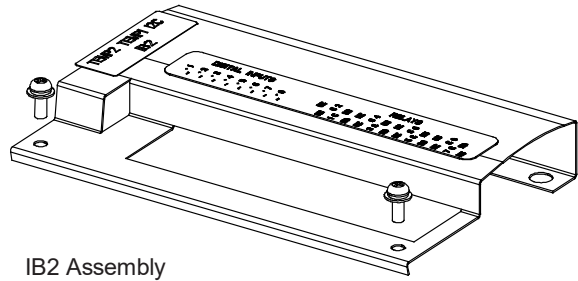
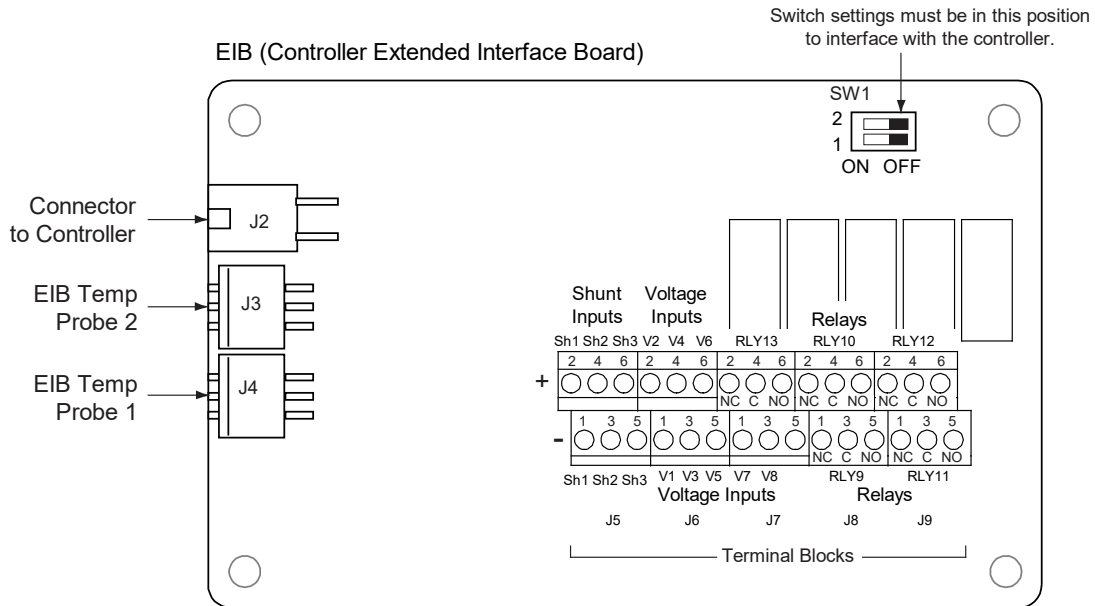

Figure 11.4 Replacing an EIB (Controller Extended Interface Board) Circuit Card



J5-J9

Wire Size Capacity: 16 AWG to 26 AWG.

Wire Strip Length: 0.20 inch.

Recommended Torque: 2.2 in-lbs.

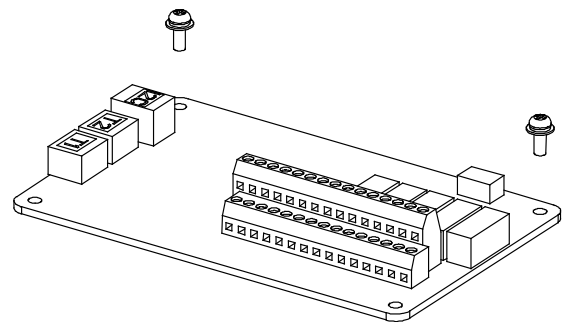
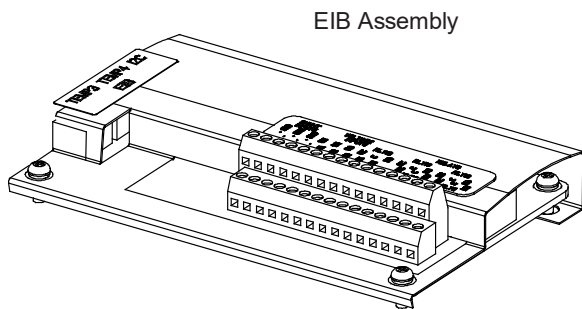
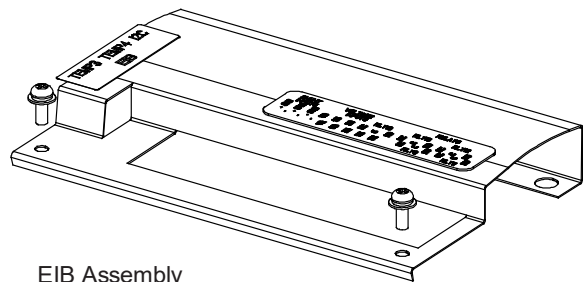

11.6.6 Replacing the Distribution Panel

Important Safety Instructions



DANGER! Adhere to the “Important Safety Instructions” starting on page vi.



DANGER! All sources of AC and DC power must be completely disconnected from this system before performing this procedure. Use a voltmeter to verify no DC voltage is present on the system busbars before proceeding.

Procedure



NOTE! Refer to Figure 11.5 as this procedure is performed.

Removing the Distribution Panel

1. Performing this procedure may activate external alarms. Do one of the following. If possible, disable these alarms. If these alarms cannot be easily disabled, notify the appropriate personnel to disregard any future alarms associated with this system while the procedure is being performed.
2. Open the system cabinet’s front door, if furnished.
3. Remove access panel(s) as required to perform the following steps.
4. Remove the distribution panel cover.
5. Disconnect all system load and battery wiring from the circuit breaker positions on the distribution panel.
6. Disconnect the alarm wiring from the distribution panel. See Figure 11.5.
7. Remove the hardware securing the system load distribution device busbar to the panel. See Figure 11.5.
8. Remove the hardware securing the battery disconnect device busbar to the panel (if present). See Figure 11.5.
9. Remove the hardware securing the distribution panel to the system cabinet. Remove the distribution panel from the system cabinet. See Figure 11.5.

Installing the Distribution Panel



NOTE! In the following procedure, before making busbar-to-busbar connections, apply a thin coating of electrical anti-oxidizing compound to the mating surfaces of the busbars.

1. Orient the replacement distribution panel into system cabinet, checking to ensure no wires are pinched. Replace the hardware securing the distribution panel to the system cabinet. Refer to Figure 11.5 for hardware build-up and torque.
2. Replace the hardware securing the system load distribution device busbar to the distribution panel. Refer to Figure 11.5 for hardware build-up and torque.
3. Replace the hardware securing the battery disconnect device busbar to the distribution panel (if present). Refer to Figure 11.5 for hardware build-up and torque.
4. Reconnect the alarm wiring to the distribution panel. See Figure 11.5.
5. Reconnect the load distribution and battery wiring to the circuit breaker positions on the distribution panel.
6. Transfer the plug-in circuit breakers from the old distribution panel to the replacement distribution panel.
7. Replace the distribution panel cover.

8. Replace the access panel(s) removed above.

Restarting the System

1. Reconnect the AC and DC power sources to the system.
2. Start the system. Refer to the “Initially Starting the System” on page 41.
3. Close the system cabinet’s front door.
4. Verify no alarms are active.

Figure 11.5 Replacing a Distribution Panel

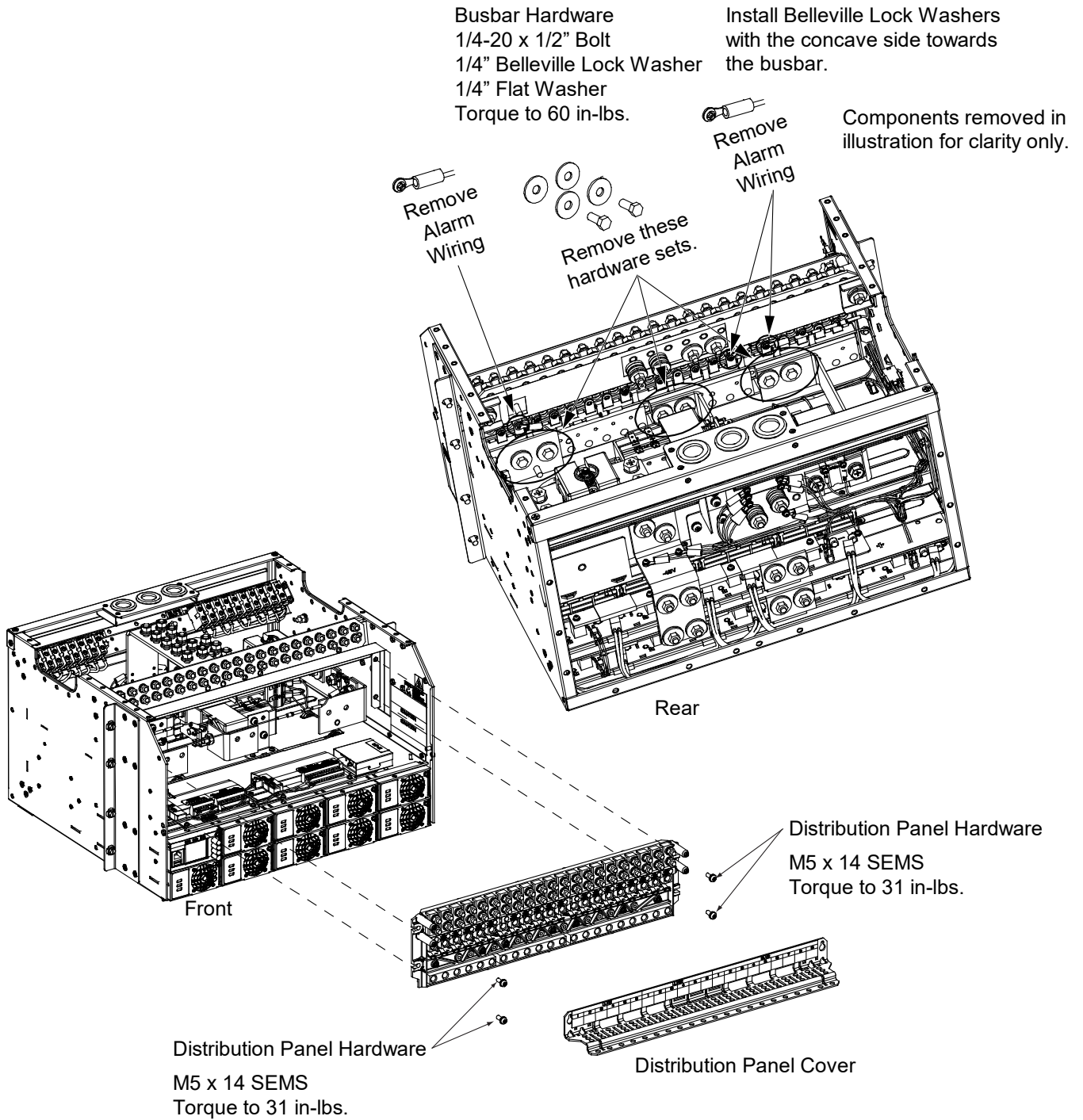

11.6.7 Replacing a Battery or Load Disconnect Contactor

Important Safety Instructions



DANGER! Adhere to the “Important Safety Instructions” starting on page vi.



DANGER! All sources of AC and DC power must be completely disconnected from this system before performing this procedure. Use a voltmeter to verify no DC voltage is present on the system busbars before proceeding.

Procedure



NOTE! Refer to Figure 11.6 and Figure 11.7 as this procedure is performed.

Removing the Contactor

1. Verify all AC and DC power sources are disconnected from the system.
2. Remove top covers (if present) to access the contactor.
3. Disconnect the wiring to the contactor by unplugging the quick disconnects or mating connector. Refer to Figure 11.6 and Figure 11.7.
4. For a load contactor, remove the mounting bracket screws.
5. Note the orientation of the contactor to ensure the replacement is installed the same way. Unbolt the contactor and remove. Refer to Figure 11.6.

Installing the Replacement Contactor

1. Position the replacement contactor oriented the same way as the old.
2. Secure the contactor with the hardware removed above. Refer to Figure 11.6 for hardware build-up and recommended torque.
3. For a load contactor, replace the mounting bracket screws.
4. Replace the wiring to the contactor by plugging-in the quick disconnects or mating connector. Refer to Figure 11.6 and Figure 11.7.
5. Replace the top covers (if present).

Restarting the System

1. Reconnect the AC and DC power sources to the system.
2. Start the system. Refer to the “Initially Starting the System” on page 41.
3. Verify no alarms are active.

Figure 11.6 Replacing a Load or Battery Disconnect Contactor

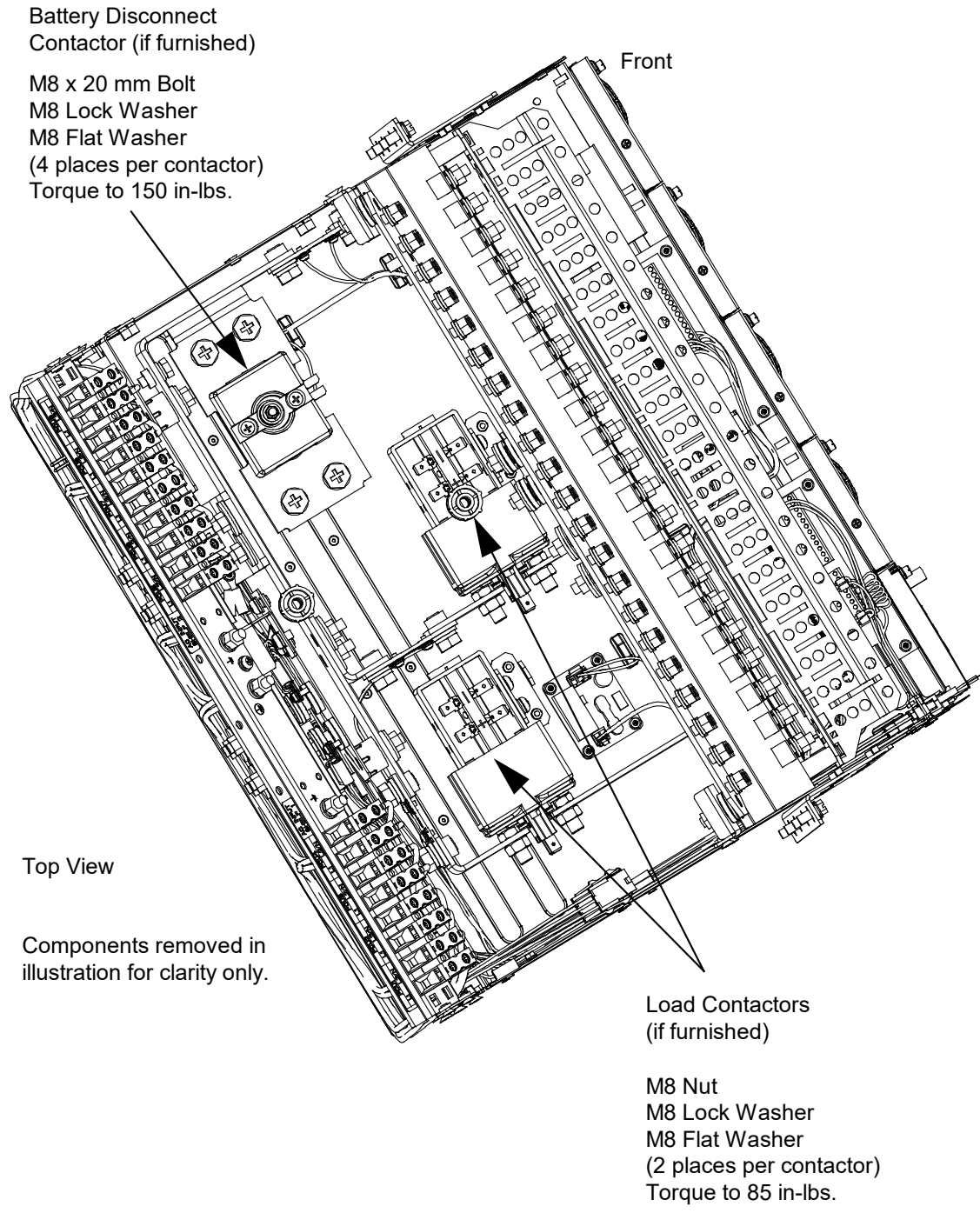

- Battery Disconnect Contactor (if furnished)
- M8 x 20 mm Bolt
- M8 Lock Washer
- M8 Flat Washer (4 places per contactor)
- Torque to 150 in-lbs.

Top View

Components removed in illustration for clarity.

- Load Contactors (if furnished)

- M8 Nut
- M8 Lock Washer
- M8 Flat Washer (2 places per contactor)
- Torque to 85 in-lbs.

Figure 11.7 Load and Battery Disconnect Contactor Wiring

Load Contactor

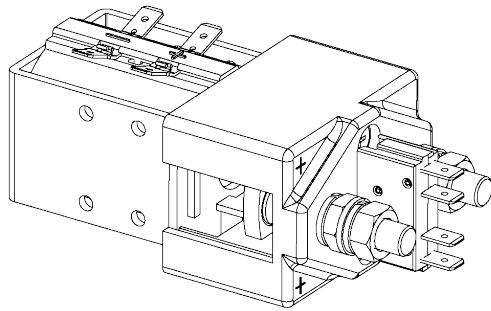

The load contactor(s) are wired with a pigtail jumper harness that plugs into a mating connector located in the power system wire harness.

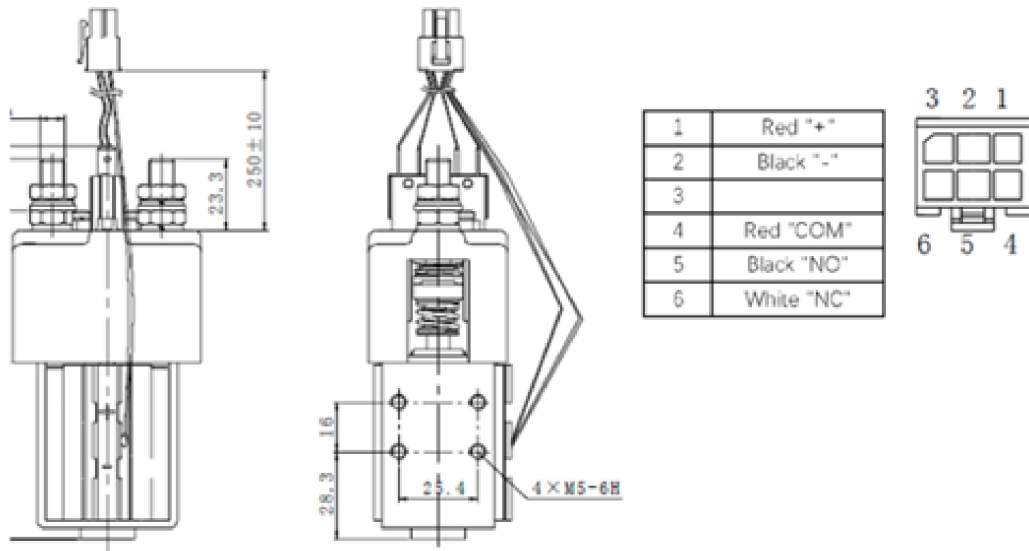

Battery Disconnect Contactor

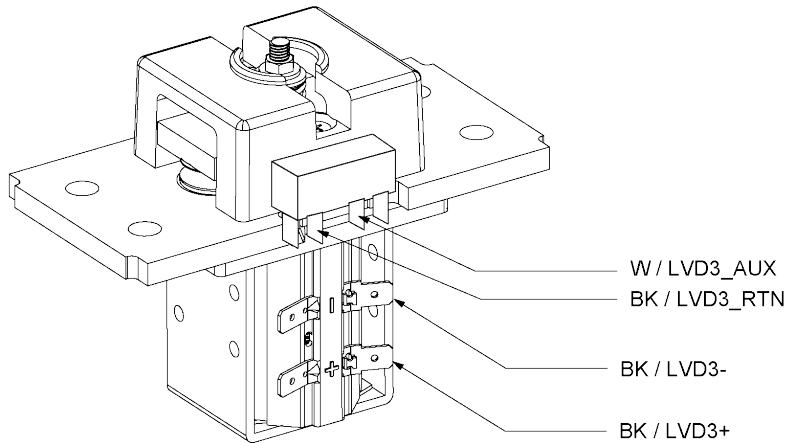

Connect with Vertiv on Social Media



<https://www.facebook.com/vertiv/>



<https://www.instagram.com/vertiv/>



<https://www.linkedin.com/company/vertiv/>



<https://www.twitter.com/vertiv/>



Vertiv.com | Vertiv Headquarters, 505 N Cleveland Ave, Westerville, OH 43082, USA

© 2023 Vertiv Group Corp. All rights reserved. Vertiv™ and the Vertiv logo are trademarks or registered trademarks of Vertiv Group Corp. All other names and logos referred to are trade names, trademarks or registered trademarks of their respective owners. While every precaution has been taken to ensure accuracy and completeness here, Vertiv Group Corp. assumes no responsibility, and disclaims all liability, for damages resulting from use of this information or for any errors or omissions.